



REHLKO *PW* 1000PRO

Standalone tower or rack mount single-phase uninterruptible power supply with internal or external batteries

(1–3 kVA)

User Manual



Table of Contents

1. Safety Instructions and Storage/ Battery Care	4
2. General Description	7
2.1 Introduction.....	7
2.2 Advanced design features.....	7
3. UPS Operating principles	8
3.1 Basic block diagram.....	8
3.2 System operating modes.....	9
3.2.1 ON-INVERTER operation.....	9
3.2.2 ON-Battery operation.....	9
3.2.3 ON-Bypass operation.....	10
4. UPS Functional Descriptions	11
4.1 Front panel display.....	11
4.1.1 4Key LCD panel.....	11
4.2 Rear panel.....	13
4.3 Communication port explanation.....	14
4.4 EPO.....	14
4.5 CS141 /SMNP adapters.....	15
4.6 Dry contact card.....	16
5. Installation and Operation	17
5.1 Unpacking UPS.....	17
5.1.1 Installation of Accessories Kit.....	17
5.2 Selecting installation position of UPS.....	18
5.3 Unpacking Extended Battery Cabinet.....	19
5.4 Selecting installation position of Extended Battery Cabinet.....	19
5.5 Installation instructions for Extended Battery Cabinet.....	20
5.5.1 4-Key LCD Panel.....	22
4 Key Panel UPS default settings and their alternatives.....	25
5.5.2 Beep Codes.....	26
6. Troubleshooting	27
6.1 Troubleshooting.....	27
6.2 Error Codes and their meanings.....	28
7. Maintenance	29
7.1 Introduction.....	29
7.2 Scheduled maintenance.....	29
7.2.1 Preventative maintenance inspection.....	29
7.2.2 Battery maintenance and testing.....	29
7.3 Battery disposal and recycling.....	30
8. Communication Software	31
8.1 Hardware setup.....	31
9. Specifications	32

1. Safety Instructions and Storage/ Battery Care

SAVE THESE INSTRUCTIONS - This manual contains important instructions that should be followed during installation and maintenance of the UPS and batteries.

Read the instructions carefully to become familiar with the equipment before starting to install. Notify the carrier and dealer if there is any damage.

	CAUTION indicates a hazardous situation which could result in potential injury or equipment damage, or to caution against unsafe practices.
	DANGER indicates potential electrical hazard which could result in serious injury or death, and special precautions are necessary.

Adhere to all national and local electrical codes.

- Always check that the supply source voltage is same as the UPS operating voltage.
- This UPS is intended for indoor use only.
- Do not operate this UPS in direct sunlight, in contact with fluids, or where there is excessive dust or humidity.
- Be sure the air vents on the UPS are not blocked. Allow adequate space for proper ventilation. Keep rear panel 20cm from wall or any obstructions.
- For a UPS with a factory installed power cord, connect the UPS power cable directly to a wall outlet. Do not use surge protectors or extension cords.
- Do not connect appliances or devices which would overload the UPS system (e.g., laser printers or scanner) to the UPS output sockets.
- The battery typically lasts for two to five years. Environmental factors impact battery life. Elevated ambient temperatures, poor quality utility power, and frequent short duration discharges will shorten battery life.
- This product cannot be used as a power supply for any life support devices.
- The equipment and batteries are heavy. Remove the batteries before installing the UPS and practice safe lifting techniques adequate for the weight of the equipment.
- Before installing or servicing the equipment check that the Disconnecting from the AC mains and load. The UPS contains internal batteries and may present a shock hazard even when disconnected from the branch circuit (mains).
- Doing wiring, maintenance service and batteries replacement should be performed or supervised by personnel knowledgeable about batteries and the required precautions.
- Please install the same battery type (lead-acid or lithium) when replacing the new batteries.
- **CAUTION:** Do not dispose of batteries by burning them. The batteries may explode.
- **CAUTION:** Do not open or mutilate batteries. Released electrolyte is harmful to the skin and eyes, and may be toxic.
- **CAUTION:** A battery can present a risk of electrical shock and high short-circuit current through conductive materials could cause severe burns. The following precautions should be observed when working on batteries:
 - Before installing or replacing the batteries, remove jewellery such as wristwatches and rings, or other metal objects.
 - When working on batteries should wear rubber gloves and boots. Also, must use tools with insulated handles, and do not lay tools or metal parts on top of batteries.
 - Remove battery grounds during installation and maintenance to reduce likelihood of shock.
 - Remove the connection from ground if any part of the battery is determined to be grounded.

- External battery cabinet installation instructions, please refer to Battery Bank Installation User's Manual.
- **WARNING:** This is a category C2 UPS product. In a residential environment, this product may cause radio interference, in which case the user may be required to take additional measures.

Important safety notes



CAUTION Please read the following notes carefully prior to installation and use.

1. The UPS warranty will become null and void if liquids are spilt on the UPS case, or foreign objects are dropped into the unit. Such mishaps could severely damage the UPS and present a shock hazard to anyone who touches the unit.
2. The ventilation grills on the UPS front panel must be kept free of obstruction at all times.
3. The UPS is must be installed in a sheltered and controlled environment away from direct sunlight. The operating temperature should be between 0~40°C (ideally 20°C) with relative humidity of 0~90%, non-condensing. Further details concerning the installation environment are included in the installation chapter of this manual.
4. Before installing the equipment you must check to ensure that the input voltage stated on the UPS data-plate on the back of the unit matches your local utility supply voltage.
5. The UPS warranty will be rendered void, and the manufacturer reserves the right to refuse replacement or compensation, if the UPS malfunctions due to:
 - Accidental damage to the UPS.
 - Damage or malfunction due to installing the UPS in an environment that does not meet the conditions specified in this manual.
 - Damage or malfunction due to improper installation, configuration or maintenance carried out by an unauthorised person.

Storage instructions

If you intend to store the UPS for an extended period, in a moderate climate, the batteries should be charged for 12 hours every 3 months by connecting the UPS to the utility supply. If the ambient temperature at the storage location is above 25°C, this should be carried out every 2 months.



CAUTION Always switch off the UPS before moving it.

2. General Description

2.1 Introduction

Congratulations on your purchase of the Rehlko PW 1000PRO (1-3kVA) UPS.

High reliability, low operating cost and excellent electrical performance are just some of the highlights of this innovative UPS solution.

Rehlko specialises in the installation and maintenance of uninterruptible power systems; and this UPS is just one example of our wide range of state-of-the-art power protection devices that will provide your critical equipment with a steady and reliable power supply for many years.

2.2 Advanced design features

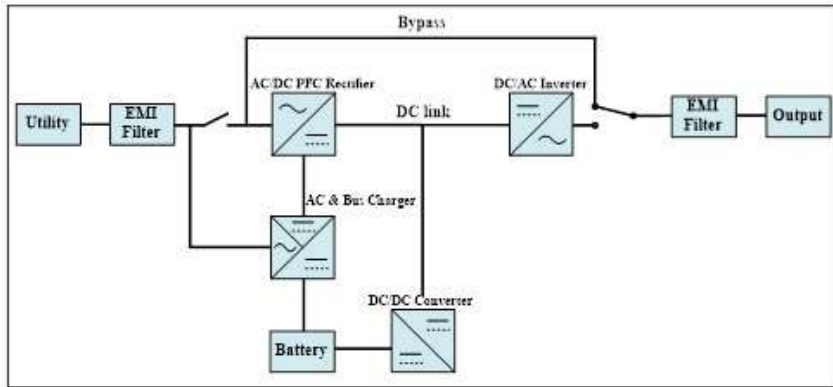
By using the latest technological developments in power engineering, the PW 1000PRO (1-3kVA) represents a new generation of transformerless UPS system. Its advanced double conversion Voltage and Frequency Independent (VFI) topology responds fully to both the highest availability and environmentally friendly requirements, compliant with IEC 62040-3 (VFI-SS-111) standards.

Following, are some of this unit's advanced design features:

- True online technology continuously supplies your critical applications with stable, regulated, transient-free pure sine-wave AC power.
- High-Frequency Transformerless technology and tower-convertible enclosure enables the UPS to be integrated into even the most difficult environments with space constraints.
- User-friendly design that permits simple and trouble-free installation. All units are supplied with input and output power cables as standard.
- Smart battery management system which extends the battery life span.
- Highly efficient PWM sine-wave technology yields excellent UPS efficiency. The high crest factor of the inverter handles peak inrush current loads and so avoids a need to upgrade to a UPS with a higher power rating.
- Compliant with various stringent international EMC standards for electromagnetic interference and protection.
- Selection of output voltages (200/208/220/230/240) available to match the UPS to local supply specifications or specific load voltage requirements.
- A selectable bypass voltage tolerance (low/high sensitivity) restricts the range of voltages that can be applied to the load when the UPS operates on bypass. The ranges are $\pm 15\%$ (low sensitivity) and $\pm 10\%V$ (high sensitivity). For example, if the output voltage setting is 230V the bypass sensitivity Low range is 230V $\pm 15\%$.
- Fully digitized control logic for better functionality and enhanced power protection. Digital signal processing (DSP) also provides efficient communication capabilities for enhanced remote control and monitoring flexibility.
- Active power factor correction (PFC) control function constantly maintains the UPS input power factor to >0.99 at 100% load, with resulting outstanding energy efficiency.
- Wide input voltage tolerance, from 110V-300V, allows the UPS to operate normally without draining the battery unnecessarily during significant mains voltage dips, which helps extend the battery service life.
- DC-start function permits the UPS to be started during a utility power failure if required.
- Overload protection system automatically switches the UPS to bypass mode if an overload occurs and automatically switch back to inverter mode once the overload condition ceases. Should the output become short-circuited, the UPS puts the system in stand-by mode, provides visible and audible alarms, and turns off the output supply automatically until the short circuit situation is resolved manually.

3. UPS Operating principles

3.1 Basic block diagram



EMI Filters

The UPS has an input and output EMI filter to reduce the effects of electromagnetic noise generated by the UPS on other adjacent equipment – e.g. reduces external radio interference.

Battery charger

A regulated battery charger, power from the AC Input supply, charges the battery whenever the input supply is available.

DC/DC Boost converter

In times of AC Input supply failure, the DC/DC Boost Converter turns on and boosts the battery voltage to a level suitable for the inverter. It provides a regulated DC output for the inverter while the battery voltage decays during discharge and includes voltage and current monitoring and overload protection.

AC/DC Converter

As its name suggests, the AC/DC Converter converts the AC Input supply into a controlled DC supply that is suitable for use by the inverter. The converter uses a leading-edge switched-mode technique which produces an input power factor of almost unity over its full operating range (0.99 at full rated linear load) and thereby maximises the UPS efficiency. The converter can satisfy the inverter DC power demands over an AC Input voltage range of between 110V–300V which means that the battery is not called upon during power dips (brownouts), thereby maximising battery life and availability.

DC/AC Inverter

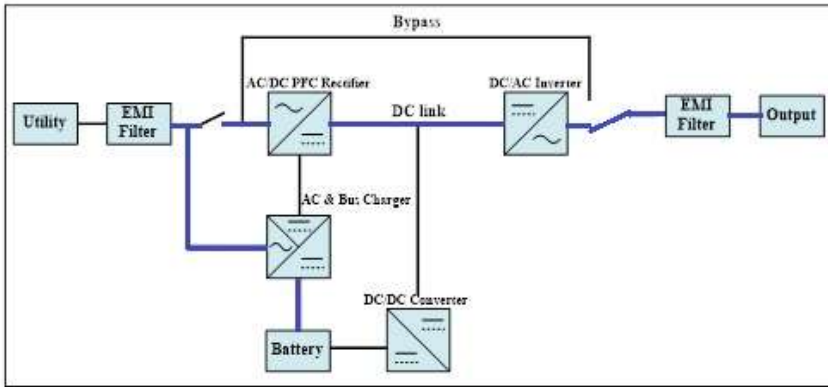
The inverter converts the DC voltage connected to its input, from the AC Input supply via the AC/DC converter or from the battery via the DC/DC converter, and produces a regulated AC Output voltage that is suitable to power the connected load equipment. The control logic associated with the Inverter power block is substantial, and in addition to the controlling the output sine wave voltage it also provides various levels of overload protection, frequency regulation and synchronisation, and output voltage error detection.

Static switch

The static switch provides a means of connecting the UPS AC Output (load) to the inverter output or the bypass line, which is connected directly to the UPS AC Input. The control logic within this power block will transfer the load to the bypass supply in the event of overload or UPS (inverter) malfunction. The load can also be transferred between the inverter and bypass line manually if required. Note that a controlled transfer can take place only if the inverter and bypass line are synchronised in frequency and phase.

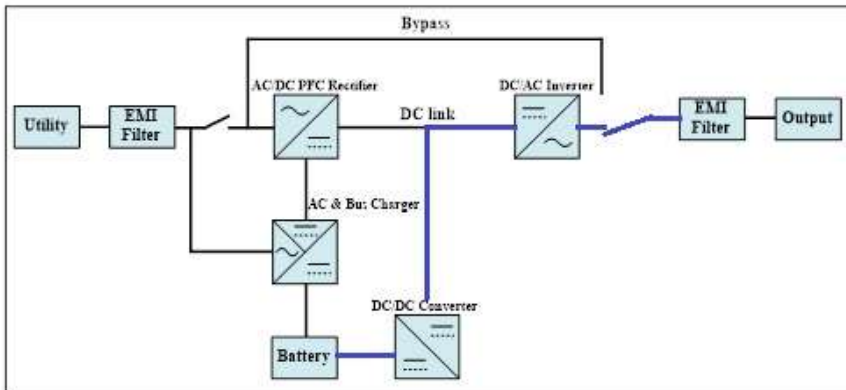
3.2 System operating modes

3.2.1 ON-INVERTER operation



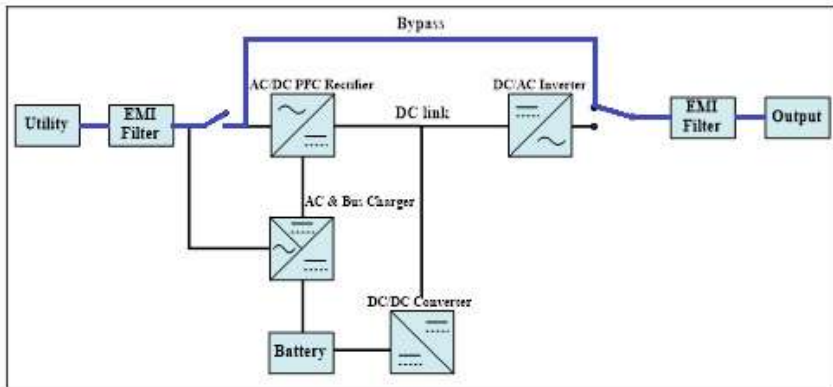
- The battery is being permanently charged by the battery charger.
- The AC/DC converter is processing the AC Input supply and turning it into controlled DC.
- The inverter is converting the AC/DC converter output back into AC suitable for the load.
- The static switch is connecting the inverter output to the UPS AC Output terminals.

3.2.2 ON-Battery operation



- The battery is discharging through the DC/DC boost converter which presents the inverter with a controlled input voltage as the battery discharges.
- The Inverter is converting the DC/DC boost converter output back into AC suitable for the load.
- The static switch is connecting the inverter output to the UPS output terminals.
- The load will continue to receive its regulated power until the battery discharges to its low voltage cut-out level.

3.2.3 ON-Bypass operation








- The battery is being permanently charged by the battery charger as long as the battery charger is still serviceable and able to operate. If the load has transferred to bypass due to an internal malfunction the battery charger may have shut down.
- The AC/DC converter, DC/DC boost converter and inverter are all inoperative.
- The static switch is connecting the bypass line to the UPS output terminals.

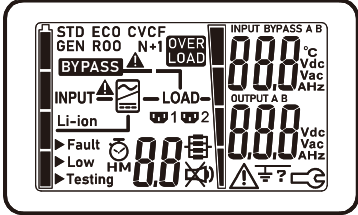

When operating in this mode the load is unprotected from utility power disturbances.

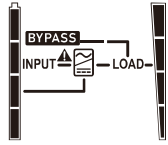






4. UPS Functional Descriptions

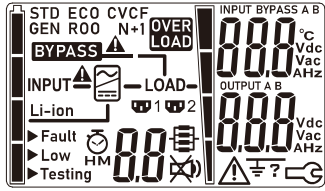
4.1 Front Panel Display








4.1.1 4-Key LCD panel

4-Key Buttons	
 	UPS On/Alarm Silence
	UPS OFF Switch
	To re-confirm the change of UPS Setting
	Select display page or change the setting of the UPS

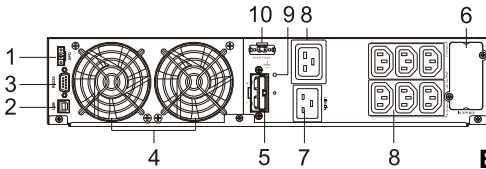
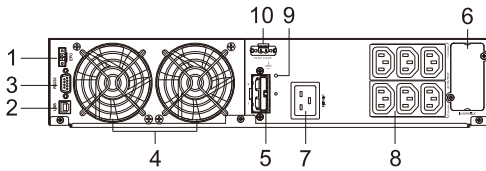
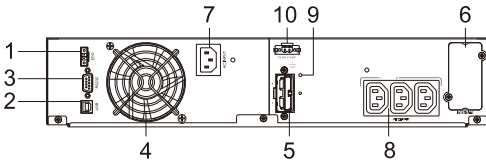
LCD display																	
<p>STD ECO CVCF GEN ROO N+1</p> 	<table border="1"> <thead> <tr> <th colspan="2">Description</th> </tr> </thead> <tbody> <tr> <td colspan="2">UPS Mode</td> </tr> <tr> <td>STD</td> <td>Standard Mode</td> </tr> <tr> <td>ECO</td> <td>ECO Mode</td> </tr> <tr> <td>CVCF</td> <td>CVCF Mode</td> </tr> <tr> <td>GEN</td> <td>Generator Mode</td> </tr> <tr> <td>ROO</td> <td>Remote On/Off Mode</td> </tr> <tr> <td>N+1</td> <td>Parallel Redundancy (1-3K Mode Not supported)</td> </tr> </tbody> </table>	Description		UPS Mode		STD	Standard Mode	ECO	ECO Mode	CVCF	CVCF Mode	GEN	Generator Mode	ROO	Remote On/Off Mode	N+1	Parallel Redundancy (1-3K Mode Not supported)
Description																	
UPS Mode																	
STD	Standard Mode																
ECO	ECO Mode																
CVCF	CVCF Mode																
GEN	Generator Mode																
ROO	Remote On/Off Mode																
N+1	Parallel Redundancy (1-3K Mode Not supported)																
	UPS Overloading																
	Bypass or Utility Abnormal																
<p>Li-ion</p>	Lithium Battery Model																
	indicate there is an output available at the Programmable Outlet 1 & Programmable Outlet 2																
<p>► Fault</p>	Battery Abnormal																
<p>► Low</p>	Battery Low																
<p>► Testing</p>	Self Test																
	Remaining battery runtime																
	Parallel Mode(1-3K Mode Not supported)																
	Buzzer Silent																



	<p>Indicates Battery Capacity level by 0-25%,26-50%,51-75%,and 76-100%</p>
	<p>Indicates Load level by 0-25%,26-50%,51-75%,and 76-100%</p>
<p>INPUT BYPASS A B</p> 	<p>Input 3-Digit Measurement Display</p>
<p>OUTPUT A B</p> 	<p>Output 3-Digit Measurement Display</p>
	<p>UPS Fault or Abnormal Warning</p>
	<p>Site Wiring Fault</p>
	<p>UPS Working in Service, Manual Bypass, Calibration mode</p>

4.2 Rear Panel

PW 1000PRO UPS



1	
2	
3	
4	
5	
6	
7	
8	
9	
10	

Ext

1. Emergency Power Off (EPO) / Remote ON/OFF (ROO) Dry contact signal inputs

2. USB port

3. RS-232 port

4. Fan

5. External Battery connector

6. Slot for optional communication cards*

7. AC power connection socket

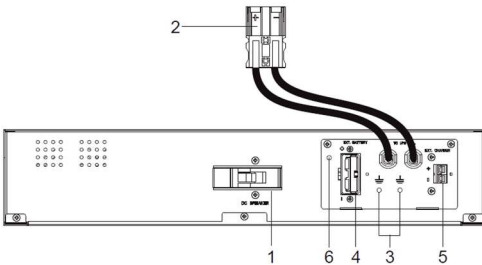
8. AC outlets(Program Relay)

9. External Battery Ground

10. Temperature compensation *(For Lead-Acid Batteries Only)

1
2
3
4
5
6

* Remark: Optional function



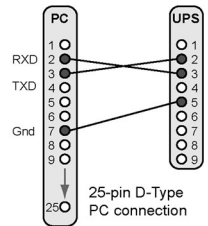
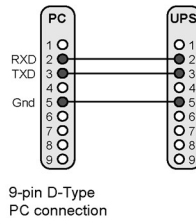
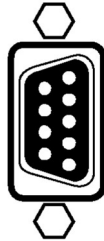
4.3 Communication Port Explanation

The UPS is equipped with a true RS-232 communication port as standard to provide communication with bundled UPS monitoring software for remote monitoring of the UPS status using a PC.

You may use optional interfaces cards for R2E (RS-232), RSE (RS-485), USE (second USB), DCE (Dry Contact), and SNMP. However, the R2E card, RSE card and USE card must not be used simultaneously.

When the optional interface cards are used together with the onboard USB port the EPO signals will get highest priority, then the SNMP/WEB card, then the shutdown command at the DCE, R2E, RSE, and USE cards, and then finally the onboard USB port gets the lowest priority.

RS-232 Interface settings	
Baud Rate	2400 bps
Data Length	8 bits
Stop bit	1
Parity	None



4.4 EPO

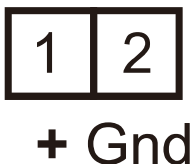
The Emergency Power Off (EPO) option allows you to turn off the UPS using an external switch or contact that is wired to the EPO terminal block on the back of the UPS. The external circuit consists of a 'normally open' external contact that will power-off the UPS when the contact is closed.

When the EPO circuit is activated the UPS output is shut down, removing power to the load, but the battery charger remains operational to maintain battery charging. An EPO alarm is shown on the LCD display but you can still scroll through and monitor the UPS input, battery and output metering.

Once the external EPO command is removed, the UPS must be restarted by pressing the UPS ON button to restore the UPS to normal operation.

The external EPO connection should be made using a screened, single pair cable (0.5mm²) with a maximum length of 100 metres.

Pin Assignment

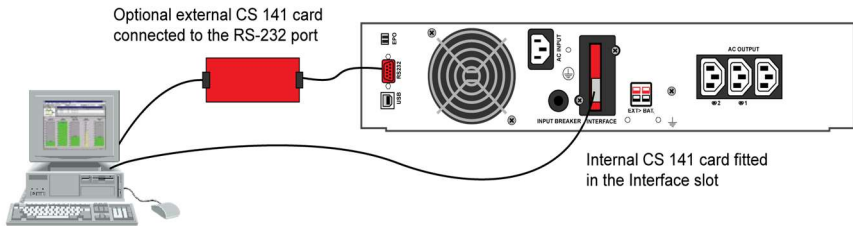


Function setting:

1. EPO NC Shutdown UPS
2. EPO NO → Shutdown UPS
3. ROO NC → Start-up UPS
4. ROO NO → Start-up UPS

this function setting by setting tool

4.5 CS141 /SNMP adapters



Simple Network Management Protocol (SNMP) is a world-wide, standardised communication protocol that can be used to monitor any network-connected device via a simple control language and display the results in a browser-based application. The software agent built in to the CS141 adapter card makes the UPS data available in this SNMP format which can then be utilized by a number of UPS management software applications.

The card contains a serial interface, which can be connected directly to a computer's serial port, and an RJ-45 connector which allows it to be connected to a network using a standard CAT-5 cable. The SNMP adapter can be configured via Telnet, http (browser) or serial connection. For normal operation, at least one Ethernet network connection is necessary.

Once installed, the UPS-Management software agent, which is already installed in the card, monitors the UPS operation and outputs its data in SNMP format to the connected network. The card enables automated generation of event/alarm emails, server controlled shut down (with optional licenses) and other tasks, and can also be integrated with BMS software over a local area network (LAN) for SNMP or Modbus information over IP.

Rehiko offer monitoring software with SNMP functionality for Novell, OS/2, and Windows that run both on INTEL and on ALPHA, DEC VMS and Apple.

An optional external SNMP adapter can be connected to the UPS via its RS232 port if the UPS card slot is in use (e.g. DCE card fitted) but SNMP facilities are still required.

RCCMD

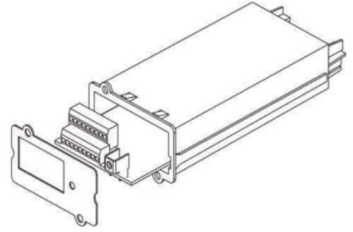
RCCMD (Remote Console Command Module) for 'multi-server shut down' is an independent software module intended for transmitting and receiving 'remote commands'. Using the 'RCCMD send' function, the SNMP adapter can send status messages to connected users or initiate automatic shut down throughout the whole network. Our CS141 SNMP adapters are fully compatible with RCCMD.

4.6 Dry Contact card

DCE-F is an UPS management product for monitoring the status and **an** input contact as a shutdown UPS command. The volt-free signalling outputs can be integrated into an external alarm monitoring panel or building management system.

All the output connections are switched by independent relays. Details for configuration are provided in the documentation that accompanies the card.

Relay terminals are rated up to 40VDC, 800mA



Pin	Function
CN7_Pin_1	Shutdown+ Input Voltage Range:5~25 VDC
CN7_Pin_2	Shutdown-
CN7_Pin_3	AC abnormal (JP3 for K3 NO)
CN7_Pin_4	AC abnormal (K3 Common)
CN7_Pin_5	Battery low (JP2 for K2 NO)
CN7_Pin_6	Battery low (K2 Common)
CN7_Pin_7	UPS alarm (JP1 for K1 NO)
CN7_Pin_8	UPS alarm common (K1 Common)

5. Installation and Operation

Please read the Safety Instruction guide (Section 1) before installing the UPS.

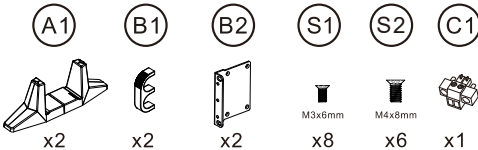
5.1 Unpacking the UPS

Inspect the UPS upon receipt. The packaging is robust, but accidents and damage may still occur during shipment. Notify the forwarder and dealer if there is damage.

The packaging is recyclable and reusable.

1. The UPS is heavy. Always practice safe lifting techniques adequate for the weight of the equipment. Remove the packing styrofoam and the plastic cover before lifting the UPS out of the box.
2. The standard package also consist of the following items:
 - A. EC output cables (for UPS with IEC sockets only)
 - B. IEC input cables (for UPS with IEC sockets only)
 - C. USB cable
 - D. Accessories Kit

RT model



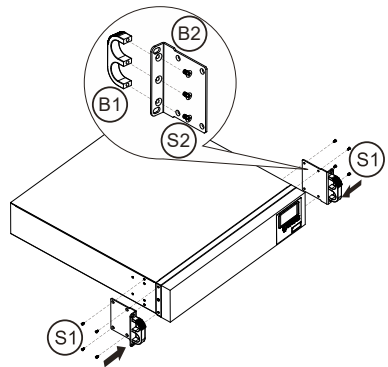
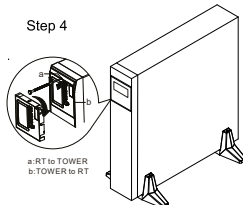
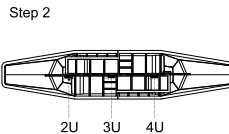
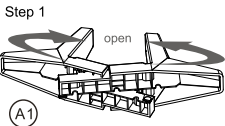
Tower model



5.1.1 Installation of Accessories Kit

Tower installation

Rack Mount installation



5.2 Selecting an installation position for the UPS

The UPS is heavy. Select a location sturdy enough to support the UPS weight. To ensure proper operation and long operating life, position the UPS according to the following requirements.

1. Keep at least 20 cm side and rear clearance away from walls or any obstructions.
2. Ensure the air vents on UPS are not blocked. Allow adequate space for proper ventilation.
3. Ensure that the installation site is free from excessive dust and the ambient temperature and humidity are within the specified limits.
4. Do not place the UPS in a dusty or corrosive environment or near any flammable objects.
5. This UPS is not designed for outdoor use.

5.3 Unpacking the Extended Battery Cabinet

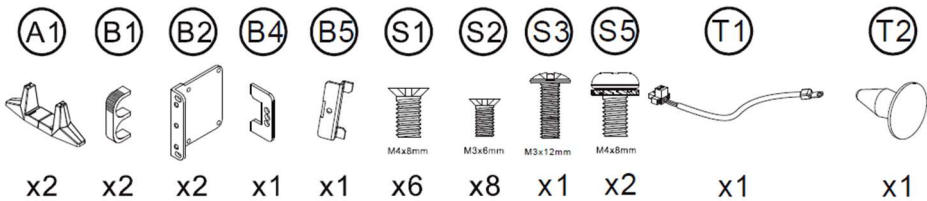
Note: The packing condition and the external outlook of the unit should be inspected carefully before installation. Retain the packing material for future use.

Unpacking

1. Remove the packing foams and take the battery bank out of the box.

Warning: The unit could be quite heavy. Check the weight of the unit before operating to avoid injury.

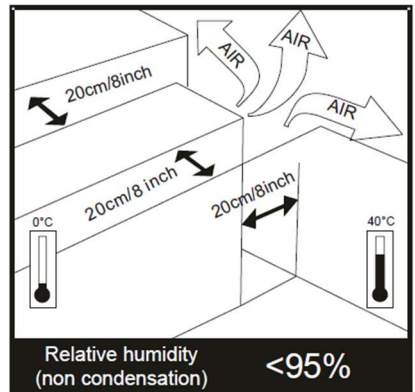
2. Standard Package includes - User's Manual
3. Accessories for Tower and Rack Mount. (Accessories will be different according as the Models.)



5.4 Selecting Installation Position for Extended Battery Cabinet

It is necessary to select a proper environment to install the unit, in order to minimize the possibility of failure to the battery bank and extend the life of the batteries. Please follow the instructions below:

1. Keep at least 20cm (8 inches) clearance from the rear panel of the battery bank from the wall or other obstructions.
2. Do not block the air-flow to the ventilation openings of the unit.
3. Ensure the installation site environmental conditions are in accordance with the battery bank working specifications to avoid overheat and excessive moisture.
4. Do not place the battery bank in a dusty or corrosive environment or near any flammable objects.
5. This battery bank is not designed for outdoor use.



5.5 Installation Instruction Extended Battery Cabinet

Installation of Accessories Kit

Tower installation

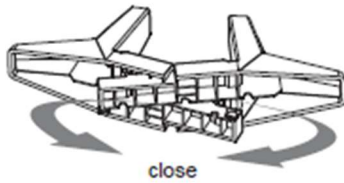
Step 1



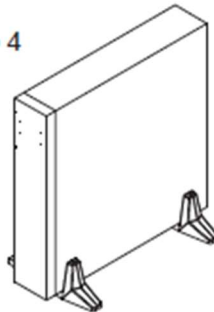
Step 2



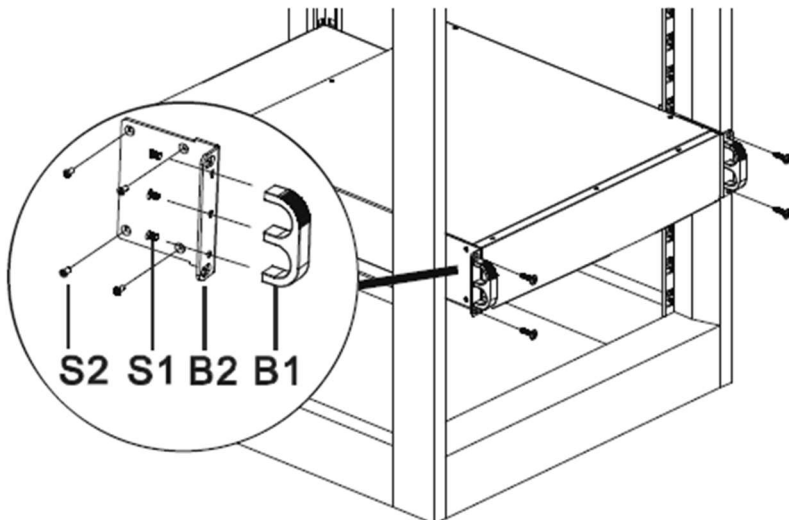
Step 3



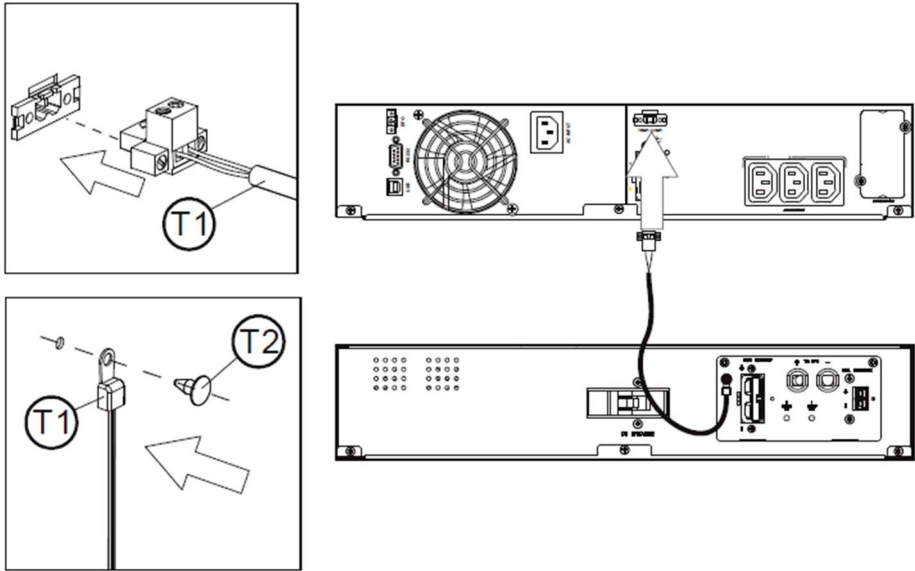
Step 4



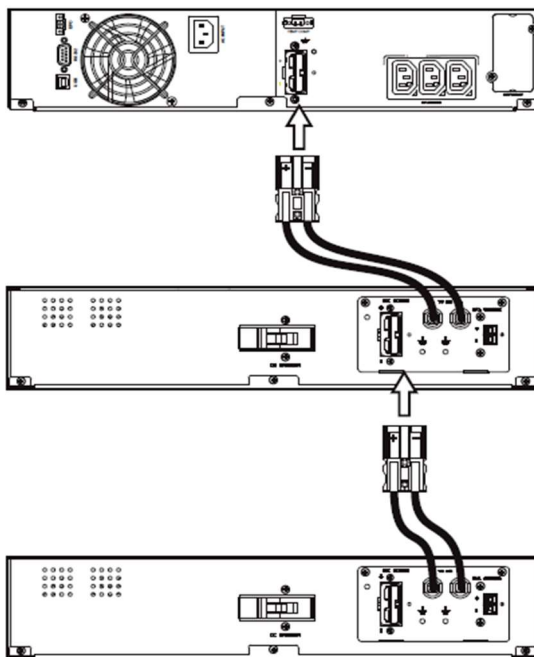
Rack Mount installation



5.6 Installation of Temperature Compensation Kit (Optional)



Connect DC Cable



5.7 4-Key LCD Panel

5.7.1.1 Line mode start up

1. Please ensure the outlet of power source is proper grounded.
2. Ensure the voltage rating of power source is matched with UPS spec.
3. Plug in UPS to the AC source
4. UPS will enter into standby mode after initialization has finished.
LCD indicator will be all lit and dim once and fan will start spinning.

Full LCD display looks as below figure:

Press **I** key and hold until twice beep heard, release button, UPS begins starting procedures and the buzzer will beep intermediately. LCD display will show as below figure-A and then figure-B sequentially. When you see figure-B means the starting up procedure is finished

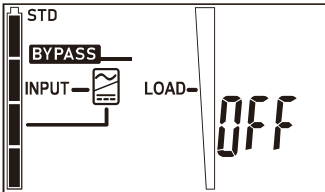


figure-A

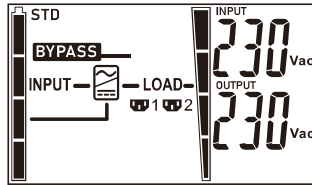


figure-B

5.7.1.2 Start-up in Battery Mode (Cold Start)

1. Ensure the internal battery is available or external battery set well connected to UPS. Press and hold **I** key for 3 seconds until twice beeps heard, release button and press **I** key for 3 seconds until twice beeps heard again to confirm cold start procedure. If the 2nd button confirmation not be finished within 10 seconds after 1st twice beeps, UPS will not cold start and shut off after 10 seconds.
2. 5 seconds after cold starting, intermittent audible alarm will be heard and LCD will show sequentially as below figure-C and figure-D.

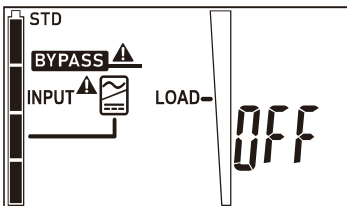


figure-C

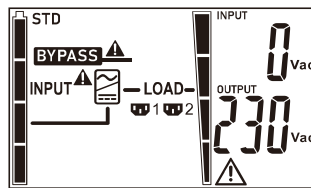


figure-D

Note: Ensure that the UPS batteries are pre-charged for at least four hours by simply connecting the AC power cord to the utility receptacle.

5.7.1.3 Operation of measurements display

Operation of measurements display


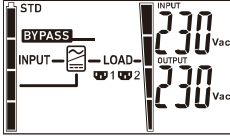
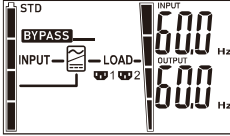
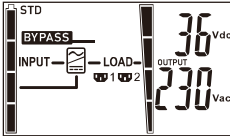
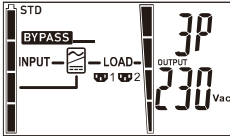
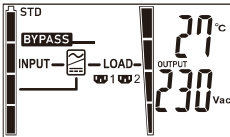
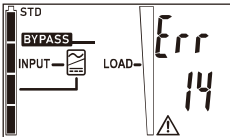
UPS measurements can be checked after UPS started by press  key. The display sequence are as below figure-E~J.



figure-E (Input/Output Voltage)	figure-F (Input/Output Frequency)
	
figure-G (Battery/Output Voltage)	figure-H (Number of Battery)
	
figure-I (Machine temperature)	figure-J (Error code)
	

Note: figure-J will only be displayed when there is an Error code and will be hidden if there is no Error code.

5.7.1.4 UPS Locked up

UPS will lock up when encountering abnormal or failure condition. Refer to the LCD display as shown below figure-K.

The procedures to release UPS from locked up status as below:

- press  key switch to Error code page (figure-J), Check and record the error code.
- Check user's manual to understand possible cause, solve the problem or call service provider.
- Press  key and hold for 5 seconds until twice beep heard.
- Unplug AC input power cord or turn off power source switch.
- After UPS completely shut off, UPS is unlocked.

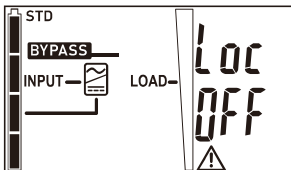


figure-K

5.7.1.5 UPS Default Data and Special Function Execution








- (a) After the UPS completely wake up(Standby mode), Press  key and  key simultaneously for approximately three seconds to change the LCD display to figure-L. Press the  key for 2 seconds to scroll through the UPS setting pages. The LCD will display in sequence figure-L~U.
- (b) Press  Key to change the setting options.
- (c) Press and hold  Key to switch between the units, tens, and hundreds digit fields.
- (d) Press and hold  Key for 3 seconds to save settings.
- (E) Press and hold  Key for 3 seconds to quit setting mode.



figure-L (Bypass Frequency Sensitivity window)		figure-M1 (Bypass Voltage Sensitivity window)	
L	 <p>Frequency Window is +/-3 Hz.</p>	M1	 <p>Bypass Voltage is adjusted to wide range.</p>


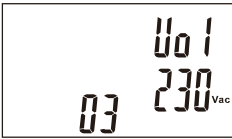
figure-M2 (Bypass Voltage Sensitivity window)		figure-N (Inverter Voltage)	
M2	 <p>Bypass Voltage is adjusted to narrow range.</p>	N	 <p>Inverter output voltage</p>

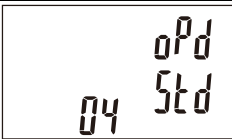
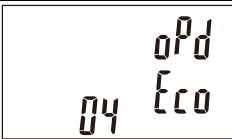
figure-O1 (normal mode)		figure-O2 (Eco mode)	
O1	 <p>The UPS is operating in "normal mode".</p>	O2	 <p>The UPS is operating in "Eco mode".</p>

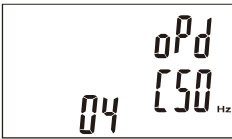
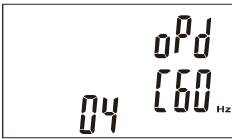
figure-O3 (CVCF 50 Hz mode)		figure-O4 (CVCF 60 Hz mode)	
O3	 <p>The UPS is operating in "CVCF 50 Hz mode".</p>	O4	 <p>The UPS is operating in "CVCF 60 Hz mode".</p>

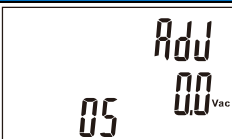
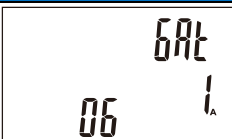
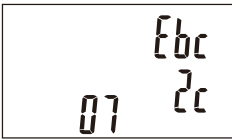

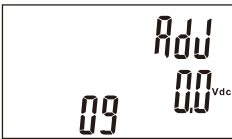
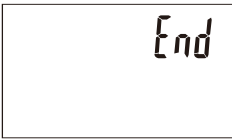


figure-P (Inverter Voltage Adjust-positive values)		figure-Q (Charger Current)	
P	 <p>Inverter Voltage Adjustment (-6.0V ~ +6.0V)</p>	Q	 <p>UPS Charger Current</p>

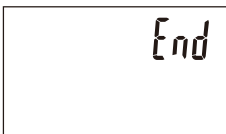
figure-R (Number of Battery Bank)		figure-S (Battery Total AH)	
R	 <p>Total number of external battery bank (only for displayed when the battery bank function is enabled)</p>	S	 <p>Total AH of batteries (only for displayed when the battery bank function is enabled)</p>
figure-T (Charger Voltage Adjust-positive values)		figure-U (Setting end)	
T	 <p>Charger Voltage Adjustment (available only in lead-acid type standard version with Batteries & without Batteries)</p>	U	 <p>Setting end</p>

4-Key Panel UPS Default Settings and their alternatives

Make sure the UPS is not "On". Press  key and  keys simultaneously for approximately three seconds. The buzzer will sound twice, and the LCD will display figure L, indicating that the UPS is in setting mode.

- Figure-L indicates the bypass frequency window of the Inverter Output. The acceptable setting values are ± 1 Hz and ± 3 Hz.
- Figure-M1-M2 indicate the bypass input acceptable window. It follows the inverter output voltage. (i) Bypass Sensitivity Low: many selectable output voltages $\pm 15\%$ and (ii) Bypass Sensitivity High: many selectable output voltages $\pm 10\%$.
- Figure-N indicates the Inverter Output Voltage. Possible values are 200, 208, 220, 230, 240VAC.
- Figures-O1~O4 indicate the operation modes of the UPS. Possible values are Online, Eco (Economical) mode, fixed 50 Hz Output, and fixed 60 Hz Output.
- Figures-P indicates the adjustment of the Inverter Output, which may be set to -6.0V ~ +6.0V.
- Figures-Q indicates the UPS charger current. Possible values are 1, 2A.
- Figures-R indicates total number of the UPS external battery bank.
- Figures-S indicates total AH of the UPS batteries.
- Figures-T Indicates the adjustment of the charger voltage, and the setting range will be limited (13.2V~14V/per).

After changing settings you must press and hold  key to save all of your changes.





* Press the Enter key to save changes.

Turn off the Utility Input breaker.

Your setting changes are now complete.

5.7.1.6 Turn UPS off

Line mode(AC input available) : Press Off  key and hold until twice beeps heard, UPS output will shut off. UPS will stay in standby mode, fan(s) keep spinning and battery will be remained recharging if AC input still available after output is off, otherwise it will be shutdown completely.



(2) Backup mode (AC input not available): Press Off  key and hold until twice beeps heard, UPS output will shut off. 10 seconds later, fan stop spinning and UPS shutdown completely.

5.7.1.7 Self-Test (Line mode only)



This function is for checking battery capacity of battery pack in AC mode. It will perform backup mode test for 10 seconds after receiving self-test command by front panel. You can press and hold

 Key for 3 seconds to perform the 10 seconds self-test.



ECO mode Setting (Line mode only)

To press and hold  Key and  Key for 5 seconds until twice beep heard to switch.

Manual Bypass operation (Line mode only and Bypass window normal)

To press and hold  Key and  Key for 3 seconds until twice beep heard to switch.

5.7.1.8 Manual Bypass operation (Line mode only and Bypass window normal)

press "ON-KEY" and "Up-KEY" key simultaneously for approx. 3 seconds to transfer from "Inverter to Bypass" (the bypass led continuously "blink" and the buzzer will beep intermediately or "Bypass to Inverter")

5.7.2 Beep Codes


The following table contains common UPS statuses with their beep codes.

UPS Status	Beep Code
UPS faulty, Inverter shut down. All functions inhibited.	Long continuous beep
Control keypad error	Long continuous beep
UPS faulty, loads continue to be supplied via Inverter or Bypass.	Single beep every two seconds
In battery mode	Single beep once per second
Battery low	Quick and short successive beeps
Confirm RS-232 port receiving	Two quick and short beeps
Service mode okay	One quick and short beep

6. Troubleshooting

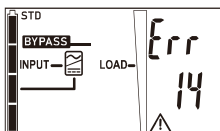
6.1 Troubleshooting

If the UPS malfunctions during operation please check that all lines are connected properly and that the utility specifications are correct. Refer to the table below to troubleshoot. Should the problem persist please contact your local dealer for assistance.

Situation	Check Items	Solution
Fault  LED Read the error code (see next page) displayed by the combination of LEDs, and verify the fault as follows.	1. Er05,Er39	1. Check the battery connection. Measure battery voltage to ensure that batteries are charged and healthy. Recharge batteries for 8 hours if necessary. Simulate utility outage to verify that UPS is able to provide DC backup. Otherwise consult your local dealer right away.
	2. Overload	2. Disconnect some non-critical loads from the UPS output until the overload ceases. Check if there is any short circuit between cables due to broken cable insulation. Replace the cables if necessary.
	3. Er11 (UPS Over Temperature)	3. Remove any objects obstructing the ventilation louvers. Verify that the cooling fans are working properly. Contact your local dealer to replace the fans if necessary.
	4. Site wiring/Ground fault	4. Check if the "L" and "N" phases of the utility AC source have been wrongly wired or if the Ground-Neutral voltage exceeds the limits.
	5. Er14 (Fans out of order)	5. Verify that the ventilating fans are functioning properly. Do not attempt to replace the fans yourself. Contact your local dealer for replacement.
	6. Other error codes	6. Consult your local dealer for assistance.
UPS fails to provide battery backup or its backup time is shorter than its intended performance.		If the backup time remains unsatisfactory after 8 hours of charging please contact your local dealer for battery replacement.
UPS is normal, but there is no output to the load.	Check that all power cords are properly connected.	If the problem persists consult your local dealer for technical assistance.
The UPS switches into battery mode and then back into utility mode when a connected device is turned on, or the UPS switches back and forth between battery and utility modes.	A power strip is connected to the UPS. See if there is any damage to the utility wall receptacle or if the cord plug is faulty.	1. Do not use the power strip. 2. Replace the wall receptacle/cord plug.
Strange noise or smell		Shut down the whole system immediately. Disconnect the power from the UPS and contact your local dealer.
UPS is unable to provide backup power.		Check that the battery connectors are fully engaged. Allow the batteries to recharge if they are weak. If the problem persists after recharging the batteries, consult your local dealer for assistance.

Checking error code on LCD panel :

If UPS is in abnormal condition , common alarm sign  will light up and come with audible alarm.



4Key LCD Panel

6.2 Error Codes and Their Meanings

Code	Meaning
Er05	Battery weak or faulty
Er06	Output short-circuited
EPO	EPO mode
Er11	UPS over-temperature
Er12	Inverter overload
Er14	Fan errors
Er39	When UPS start process, Utility Voltage less than 110V and Battery no connection.
Er28	Bypass overload

7. Maintenance

7.1 Introduction



WARNING: Do not remove the covers from the UPS case. If you remove a cover from the UPS case you will be exposed to potentially lethal voltages.

The UPS does not contain any user-serviceable parts, so the day-to-day maintenance requirements are minimal other than to ensure that the environment in which the UPS is installed is kept cool and dust free. A clean, controlled operating environment will help maximise the useful working life and reliability of both the UPS and its batteries.

7.2 Scheduled maintenance

The UPS system and batteries should receive regular preventative maintenance from a trained engineer to maximise both the useful working life and system reliability. If the UPS is commissioned by a Rehlko service engineer, the engineer will leave a service record book with the UPS which will be used to log its full service history.

We recommend that the UPS system is maintained every six months by a Rehlko trained engineer or approved service agent, who will complete the following. Preventative maintenance inspections form an integral part of all Extended Warranty Agreements (maintenance contracts) offered by Rehlko.

7.2.1 Preventative maintenance inspection

During a preventative maintenance inspection a trained Rehlko engineer will check and validate:

- Site environmental conditions
- Integrity of the electrical installation
- Cooling airflow
- Load characteristics
- Integrity of alarm and monitoring systems
- Operation of all installed options
- All stored event logs

7.2.2 Battery maintenance and testing

The batteries should be inspected and tested every six months, depending on the ambient temperature.

The battery test takes approximately two minutes to complete and can be performed only if:

- There are no alarm conditions present.
- The battery is fully charged.
- The UPS input mains supply is present.

The battery test procedure can be carried out from the UPS front panel and performed irrespective of the UPS operating mode (ON-INVERTER or ON-BYPASS/ECO) and whether or not the load is connected.

7.3 Battery disposal and recycling



WARNING: Do not attempt to remove or replace the UPS battery yourself. If a battery is faulty ALWAYS seek assistance from Rehlko or one of its local service agents.

Batteries contain dangerous substances that can harm the environment if disposed of carelessly. If you have a faulty battery it should be checked and replaced by a trained Rehlko engineer who will dispose of any faulty batteries in accordance with any regulations set by local environmental waste disposal organisations.



8. Communication Software

8.1 Hardware Setup

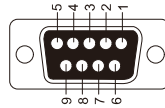
1. Connect to either RS-232 communication or USB communication.
2. Connect a male RS-232 connector or a USB cable* to the UPS communication port. Connect the female RS-232 connector or the other end of the USB cable to the computer.

True RS-232

The RS-232 interface must be configured as follows.

Baud Rate	2400 bps
Data Length	8 bits
Stop Bit	1
Parity	None

Pin Assignments:

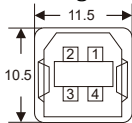


Pin 3: RS-232 Rx
Pin 2: RS-232 Tx
Pin 5: Ground

USB Pin Assignments:

The USB communication protocol definition is as below.

1. Complies with USB version 1.0, 1.5 Mbps.
2. Complies with USB HID version 1.0.
3. Pin Assignments:



1 → VCC (+5V)
2 → D-
3 → D+
4 → Ground

Software Installation

Please refer to the software user's manual.

9. Specifications

Model	230V – 1K	230V – 2K	230V – 3K
VA	1000 VA	2000 VA	3000 VA
W	1000W	2000W	3000W
Topology / Type	Double Conversion On-Line / Rack/Tower Convertible		

INPUT

Voltage Rating	110Vac~300Vac , Single Phase 160~300 Vac: 0 ~ 100% Load 140~160 Vac: 0 ~ 80% Load 110~140 Vac: 0 ~ 60% Load
Frequency Rating	44-66 Hz 50Hz fin> 40Hz and fin < 60Hz 60Hz fin> 50Hz and fin < 70Hz
Phase	Single phase with ground
Power Factor	≥ 0.99 at full linear load
Current harmonic	THDi < 5% (Nominal voltage with <1% V _{THD} for 100% linear load)

OUTPUT

Voltage	230 Vac, adjustable to 200/208/220/230/240 Vac (200Vac / 208Vac with 80% power capacity derating)
Voltage Regulation	Static : within ±1% until low-battery warning
Frequency Regulation	±0.1Hz unless synchronized to line
Frequency (Synchronized Range)	50Hz system 47Hz ~ 53Hz (selectable: 49Hz ~ 51Hz) 60Hz system 57Hz ~ 63Hz (selectable: 59Hz ~ 61Hz)
Crest Factor	3:1
Power Factor	1.0
Voltage Harmonic Distortion(THDv)	THDv < 2% at full linear load THDv ≤3.5% at 0.9 non-linear load
Output Waveform	Pure sine wave

Efficiency

Online VFI mode	Up to 93%
ECO mode	Up to 98%

Transfer time

AC to DC	0 ms
----------	------

Battery (VRLA Lead Acid Type)				
Battery System Voltage		36Vdc	72Vdc	72Vdc
Number of batteries / string		3	6	6
Battery type		12Vdc /7Ah	12Vdc /9Ah	12Vdc /9Ah
Uptime with internal battery in minutes	50% load	10	11	9
	100% Load	3	3	2

Charger				
Charge Current	Standard	1A / 2A selectable		
	Optional	1A / 2A / 4A / 8A selectable		
Recharge time (to 90%)		5hr (2A Charging Current For Internal Battery)		
Charge Voltage	Lead-Acid Battery	40.95Vdc \pm 1%	81.9Vdc \pm 1%	81.9Vdc \pm 1%
	Lithium Battery	42Vdc \pm 1%	84Vdc \pm 1%	84Vdc \pm 1%

Outlet			
Outlet	3 x IEC 320-C13	6 x IEC 320-C13	6 x IEC 320-C13 1 x IEC 320-C19

Protection

Overload in Line Mode	<p style="text-align: center;">< 105% continuous</p> <p>106-110% for 10 minutes and then switch to the bypass mode</p> <p>111-130% for 1 minutes and then switch to the bypass mode</p> <p>131-150% for 10 seconds and then switch to the bypass mode</p> <p>151-250% for 0.2 seconds and then switch to the bypass mode</p> <p>> 250% for 0.1 seconds and then switch to the bypass mode</p>
Overload in Backup Mode	<p style="text-align: center;">< 105% continuous</p> <p>106-110% for 30 seconds shuts down</p> <p>111-130% for 10 seconds shuts down</p> <p>131-150% for 1 seconds shuts down</p> <p>151-250% for 0.2 seconds shuts down</p> <p>> 250% for 0.1 seconds shuts down</p> <p>Buzzer continuously alarms.</p>
Overload in ECO Mode	<p style="text-align: center;">< 105% continuous</p> <p>106-110% for 10 minutes and then shutdown</p> <p>111-130% for 2 minutes and then shutdown</p> <p>131-150% for 10 seconds shuts down</p> <p>151-250% for 0.32 seconds shuts down</p> <p>> 250% for 0.16 seconds shuts down</p> <p>Buzzer continuously alarms.</p>
EPO	UPS shuts down immediately.

Physical

Dimensions W x H x D	mm	440 x 88 (2U) x 454	440 x 88 (2U) x 640	440 x 88 (2U) x 640
Net Weight	kg	16	25	27

Interface

Standard	RS232, USB, EPO/ROO
Option	<p style="text-align: center;">SNMP card / Relay card</p> <p>Temperature compensation (available only in lead-acid type standard version with Batteries & without Batteries)</p>

Environmental

Operating Temperature	0°C to +40°C The battery must be maintained at 20°C to ensure its lifespan is not reduced)			
Non-operating/Storage Temperature	UPS without Batteries: -10°C to +50 °C UPS with Lead-Acid Batteries: -10°C to +40 °C			
Relative Humidity	<95% RH @ 0°C to 40°C (Non-condensing)			
IP Rating	IP 20			
Operating elevation	0 to +2,000 m without derating of output power			
Pollution Degree	2 (non conductive pollution, temporary conductivity caused by condensation)			
Overvoltage Category	CAT II			
Applicable power grid power distribution system	TN			
Noise Level	Line mode (battery full charged)	<45dBA @ 1 metre	<55dBA @ 1 metre	<55dBA @ 1 metre
	Backup mode	<50dBA @ 1 metre	<55dBA @ 1 metre	<55dBA @ 1 metre

Standards and Certifications

Safety	IEC/EN 62040-1/ 62040-3/ 62040-4			
EMC	EN IEC 62040-2:2018 C2			
Markings	CE, UKCA			

Extended Battery Cabinet

Model	For 1 kW	For 2-3 kW
Battery Type	Lead Acid	
Voltage Rating	36vDC	72vDC
Output Current (Max)	50A	
Battery Quantity	6	12
Capacity x Strings	7Ah x 2	9Ah x 2
Dimensions WxHxD mm	440 x 88 (2U) x 464	440 x 88 (2U) x 583
Weight Kg	No Battery	6
	With batteries	19
Operating Temperature	0°C to +40°C (20°C to ensure lifespan is not reduced)	
Non-operating / Storage Temperature	Without Batteries: -10°C to +50 °C With Lead-Acid Batteries: -10°C to +40 °C	
Relative Humidity	<95% RH @ 0°C to +40°C (Non-condensing)	
IP Rating	IP 20	
Operating Elevation	0 to +2,000 m	
Pollution Degree	2 (non conductive pollution, temporary conductivity caused by condensation)	
Overvoltage Category	CAT II	
Compliance and Certifications	CE, UKCA	

