



REHLKO *PW* 1000

Standalone tower or rack mount single-phase uninterruptible power supply with internal or external batteries

(6-10 kVA)

Technical Specification

REHLKO PW 1000 (6-10KVA) UPS SYSTEM DESCRIPTION

By using the latest technological developments in power engineering, the Rehlko PW 1000 (6-10kVA) represents a new generation of transformerless UPS-System. Its advanced double conversion Voltage and Frequency Independent (VFI) topology responds fully to both the highest availability and environmentally friendly requirements, compliant with IEC 62040-3 (VFI-SS-111) standards.

The PW 1000 (6-10kVA) can be used as a stand-alone UPS or as a parallel system comprising up to four PW 1000 (6-10kVA) modules – configured for 'capacity' or 'redundant' operation. The UPS cabinet and associated battery cabinet can be mechanically configured as a floor-standing tower unit or installed in a standard 19 inch rack. An accessory pack containing all the parts necessary to configure the unit for either type of installation is supplied with the UPS.

Rehlko PW 1000 (6-10kVA) UPS model range

The full PowerWAVE 1000 UPS range comprises models rated from 1.0 kVA to 10 kVA. This specification applies to 6 kVA and 10 kVA models only, each of which is designed as a self-contained UPS comprising a rectifier, battery charger, inverter and static switch. The UPS batteries are housed in a separate, matching cabinet which can be attached to the main UPS enclosure to form a single unit when installed as a tower system. Up to six external battery cabinets can be connected in tandem as part of the UPS system to provide a range of autonomy times.

Advanced design features

The highlights of the Rehlko PW 1000 (6-10kVA) UPS system include its high reliability, low operating costs and excellent electrical performance.

Its key features include:

- True online technology continuously supplies your critical applications with stable, regulated, transient-free pure sine-wave AC power.
- High-Frequency Transformerless technology and tower-convertible enclosure enables the UPS to be integrated into even the most difficult environments with space constraints.
- User-friendly design that permits simple and trouble-free installation. All units are supplied with input and output power cables as standard.
- Smart battery management system which extends the battery life span.
- Highly efficient PWM sine-wave technology yields excellent UPS efficiency. The high crest factor of the inverter handles peak inrush current loads and so avoids a need to upgrade to a UPS with a higher power rating.
- Compliant with various stringent international EMC standards for electromagnetic interference & protection.
- Selection of output voltages (200/208/220/230/240) available to match the UPS to local supply specifications or specific load voltage requirements.
- A selectable bypass voltage tolerance (low/high sensitivity) restricts the range of voltages that can be applied to the load when the UPS operates on bypass. The ranges are $\pm 15\%$ (low sensitivity) and $\pm 10\%$ (high sensitivity). For example, if the output voltage setting is 230V the bypass sensitivity Low range is 230V $\pm 15\%$.
- Selectable 50Hz or 60 Hz operation.
- Fully digitized control logic for better functionality and enhanced power protection. Digital signal processing (DSP) also provides efficient communication capabilities for enhanced remote control and monitoring flexibility.
- Active power factor correction (PFC) control function constantly maintains the UPS input power factor to >0.99 at 100% linear load, with resulting outstanding energy efficiency.
- Wide input voltage tolerance, from 110V~280V¹, allows the UPS to operate normally without draining the battery unnecessarily during significant mains voltage dips, which helps extend the battery service life.
- DC-start function permits the UPS to be started during a utility power failure if required.
- Overload protection system automatically switches the UPS to bypass mode if an overload occurs and automatically switch back to inverter mode once the overload condition ceases. Should the output become short-circuited, the UPS puts the system in stand-by mode, provides visible and audible alarms, and turns off the output supply automatically until the short circuit situation is resolved manually.

1. Depending on the prevailing load.

GENERAL SPECIFICATION

UPS CABINET

| Model Rating | | 6 kVA | 10 kVA |
|---|-----|--|---------------|
| Topology | | Double conversion on-line VFI-SS-111 | |
| Form factor | | 19"-Rack / Tower | |
| Input: | | | |
| Voltage | VAC | Single phase, 176 - 280 VAC (@100% load) Single phase, 160 - 280 VAC (@75% load) Single phase, 110 - 280 VAC (@50% load) | |
| Frequency | Hz | 45-70 Hz | |
| Power factor | | >0.99 at full rated linear load | |
| Input power connection | | Hard-wired terminal block | |
| Output: | | | |
| Output capacity | VAW | 6000 / 6000 | 10000 / 10000 |
| Rated power factor | | 1.0 | |
| Voltage | VAC | Single phase, selectable at 200/208/220/230/240 VAC | |
| Voltage regulation | % | ±1 (until low battery warning) | |
| Voltage adjustment | % | ±0%, ±1%, ±2%, ±3% | |
| Waveform | | Pure sine wave | |
| Voltage distortion (THD) | % | ≤ 2% (linear load), ≤ 7% (non linear load with CF: 2.5) | |
| Free running frequency | Hz | 50Hz / 60 Hz, ±0.2% when not synchronised to bypass line | |
| Synchronisation window | Hz | ±3 Hz or ±1 Hz (selectable) | |
| Switching time Inverter-Bypass (typical) | ms | 0 ms | |
| Overload capability (AC Mode) (Tolerance ±1%) | % | <105% Load = continuous operation, from 106%...125% Load = transfer to bypass after 600s -30s. from 126%...150% Load = transfer to bypass after 30s - 160ms >150% Load = transfer to bypass immediately Buzzer continuously alarms | |
| Overload capability (BATTERY Mode) (Tolerance ±1%) | % | <105% Load = continuous operation, from 106%...125% Load = transfer to bypass after 600s -30s. from 126%...150% Load = transfer to bypass after 30s - 160ms >150% Load = transfer to bypass immediately Buzzer continuously alarms | |
| Overload capability (BYPASS Mode) (Tolerance ±1%) | % | Up to 105% Load = continuous operation, from 106%...150% Load = shut down after 600~2 Sec. from 150%...200% Load = shut down within 2 Sec. >200% Load = shut down immediately. Buzzer continuously alarms | |
| Short circuit handling | | In normal mode: inverter fuse (internal) In battery mode: inverter fuse (internal) In bypass mode: input/bypass supply breaker | |
| Over-temperature (AC Mode) | | Switch to bypass | |
| Over-temperature (On Battery Mode) | | Immediate UPS shut-down | |
| Crest factor | | 3:1 | |
| Heat dissipation @ full linear load (approx) | W | < 450W | <650W |
| Output power connection | | Hard-wired terminal block | |
| Efficiency: | | | |
| Mains operation (Full linear load @230V) | % | 93 | 94 |
| ECO (bypass) mode (Full linear load @230V) | % | 98 | 98 |

| Model Rating | | 6 kVA | 10 kVA |
|---|-----|--|----------------------|
| Environmental: | | | |
| Temperature (°C) | °C | Operating: 0°C~40°C / Storage: -10°C~50°C 3(The battery temperature must be maintained at 20°C to ensure its lifespan is not reduced) | |
| Altitude | m | 0-1000m without de-rating | |
| Humidity | % | 20%...95%, non-condensing | |
| Sound level (@ 1 meter) | dBA | ≤60 dBA | |
| Battery charger (Batteries installed in separate cabinet): | | | |
| Battery charging (from UPS internal charger) | | 2-mode operation, 2.1A(max), Temp compensation (option) Recharge time to 90% = 4 hrs | |
| Float charging voltage | VDC | 273 VDC ± 1% | |
| Bulk charging voltage | VDC | 282 VDC ± 1% | |
| Life cycle (typical) | | Up to 5 years, at Max. 20°C temperature | |
| Communications | | | |
| Standard interfaces | | USB, EPO | |
| Optional interface (via expansion slot) | | RS-232, USB, CS141 SNMP, Modbus, Dry contact relay card | |
| Supported protocols | | J-Bus, Modbus, SEC | |
| Compatible platforms | | Windows, Linux, Mac etc | |
| Mechanical Data: | | | |
| Dimensions (UPS cabinet only) (WxHxD) | mm | 440 x 88 x 680 (2U) | 440 x 132 x 680 (3U) |
| Weight (UPS cabinet only) | kg | 24.0 | 45 |
| Dimensions (UPS +1 Battery cabinet) (WxHxD) | mm | 440 x 222 x 680 (5U) | 440 x 264 x 680 (6U) |
| Weight (UPS +1 Battery cabinet) | kg | 52 | 96 |
| Options: | | | |
| Accessories | | External bypass Additional battery cabinet(s) Output distribution 19"- rack rails (up to 1 metre) | |
| Audible Alarms: | | | |
| Battery mode | | Sounds every 1.5 Seconds | |
| Battery low | | Sounds every 2.0 Seconds | |
| Overload | | Sounds every 3.0 Seconds | |
| General error | | Sounds permanently or every 3 Seconds (error dependent) | |
| Standards: | | | |
| Safety | | IEC/EN 62040-1, UL1778 | |
| EMC-Compatibility | | EN 62040-2, EN 61000-3-2, EN61000-3-3, FCC Part 15 Class A | |
| Performance features | | EN 62040-3 | |
| Product certification | | CE (1P/1P), cTUVus (1P/1P) UKCA | |
| Protection Class | | IP 20 | |
| Manufacturing standards | | ISO 9001 | |

EXTERNAL BATTERY CABINET

| Model Rating | | 6 kVA | 10 kVA |
|--|-----|---|--------|
| Maximum number of battery cabinets | | Up to six battery cabinets per UPS module | |
| Number of battery blocks per cabinet | | 20 (connected as a single battery string) | |
| Battery type | | 12 VDC 9Ah VRLA | |
| Nominal battery string voltage | VDC | 240 VDC | |
| Dimensions (WxHxD) | mm | 440 x 132 x 680 (3U) | |
| Weight | kg | 11kg without batteries 65.4 kg with batteries fitted (20 off) | |
| Battery charging (optional external charger) | | 2-mode operation, 4.1A(max) – Recharge time to 90% = 10 hrs Required if 3 or more battery cabinets are connected | |

BATTERY AUTONOMY TIME







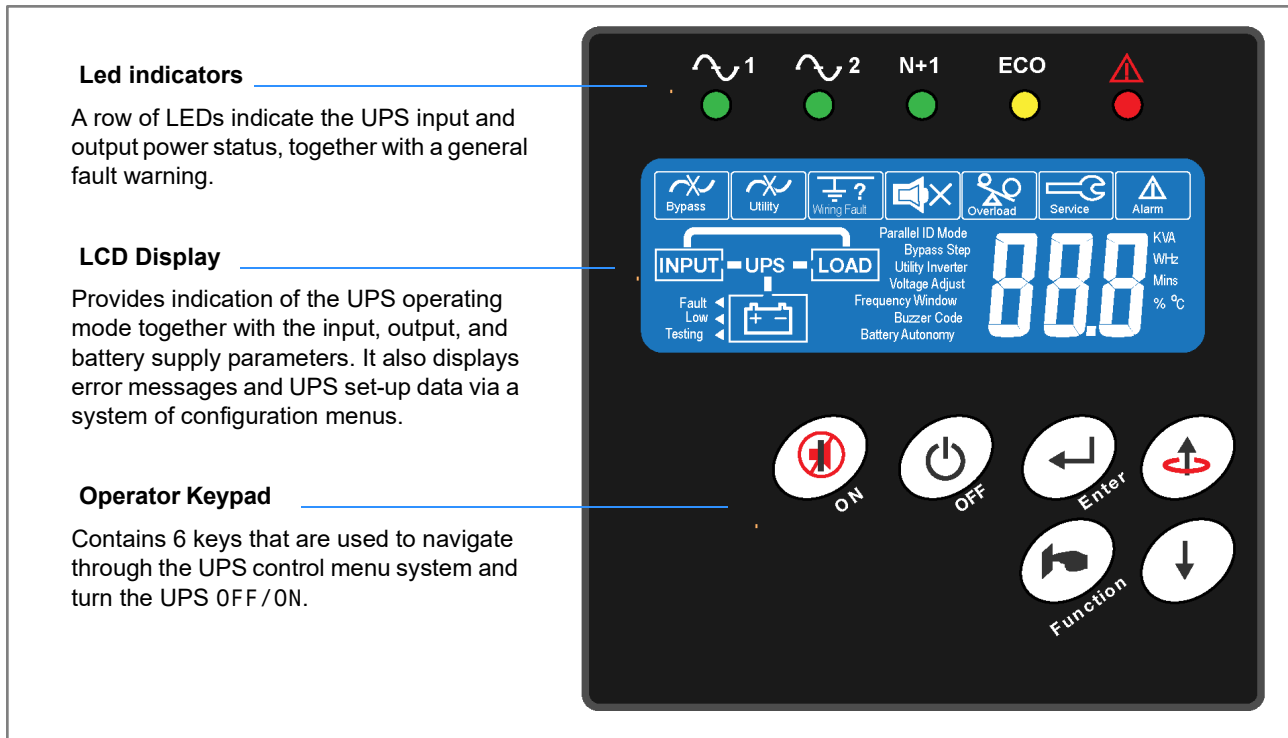



| No. of Battery Cabinets | | 6 kVA | 10 kVA |
|---|---|----------|----------|
| Number of connected battery cabinets fitted with 20x 9Ah 12V battery blocks | 1 | 12 mins. | 5 mins. |
| | 2 | 30mins. | 15mins. |
| Autonomy times given are when running with 75% linear load. | 3 | 51mins. | 19mins. |
| | 4 | 67mins. | 40 mins. |
| | 5 | 88mins. | 51 mins. |
| | 6 | 108mins. | 60 mins. |

UPS CONTROL PANEL

The front-mounted UPS Control Panel is easy to operate and comprises three areas:



LED Indicators

- 
1 Input mains supply status
 ON indicates that the UPS mains supply is within its normal operating window.
 FLASHING indicates that the UPS mains supply is not within its normal operating window.
- 
2 Bypass mains supply status (split bypass configuration in 6kVA/10kVA only)
 ON indicates that the UPS bypass supply is within its normal operating window.
 FLASHING indicates that the UPS bypass supply is not within its normal operating window.
- N+1 N+1 Redundancy status**
 ON indicates that the UPS system is able to operate in redundancy mode.
 OFF indicates that the UPS system is operating in 'capacity' mode.
- ECO ECO Mode**
 ON indicates that the UPS system is operating in ECO mode (load on bypass).
- 
UPS Fault
 ON indicates the presence of a fault condition within the UPS that needs attention. It is usually accompanied by an audible alarm.

LCD Display

The LCD display contains a row of warning symbols, a mimic diagram which indicates the power path through the UPS, a battery status indicator and a multi-function 3-digit numerical display which can be selected to indicate a range of operating parameters. Each of these areas are described below.

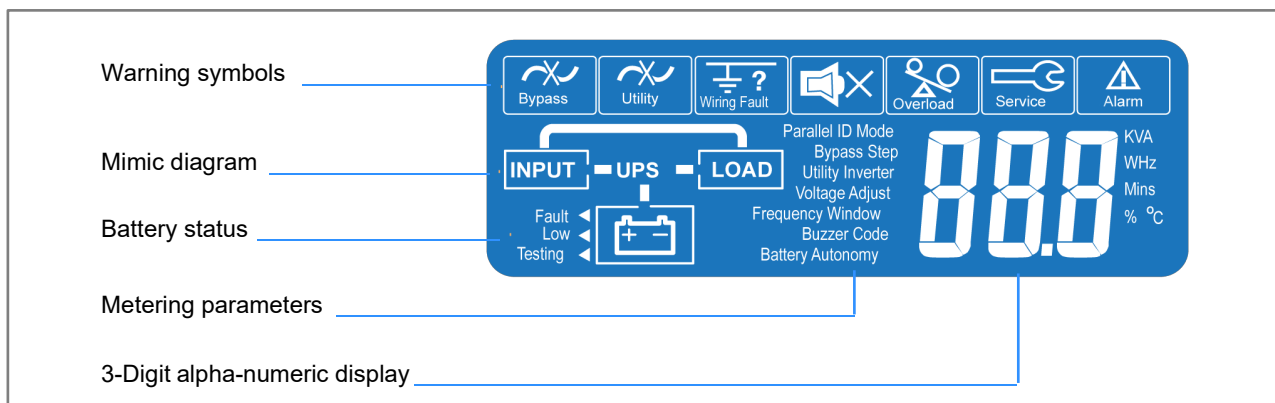

Warning symbols



Bypass input abnormal:

UPS fails to transfer to bypass, bypass abnormal in ECO mode.



Utility input abnormal:

The utility mains supply is outside the UPS pre-set operating window.



Wiring fault:

Site wiring problem such as reversed Line-Neutral connection.



Alarm buzzer silent

The alarm buzzer has been silenced or disabled.



Overload:

The UPS output is overloaded.



Service:

The UPS is operating in its service mode.



Alarm:

An alarm condition is present. This remains active after the audible alarm is reset if the alarm still exists.

Meter Display

When the UPS is turned on, you can scroll through the measurement display screens using the UP and DOWN keys on the operator keypad. The parameter display sequence is as numbered in the table below and loops around in either direction.

| | | | | | |
|---|------------------------|---|-------------------------|---|--------------------------|
| 1 | Utility Voltage (V) | 4 | Inverter Frequency (Hz) | 7 | Battery Voltage (V) |
| 2 | Utility Frequency (Hz) | 5 | Inverter Load % | 8 | Battery Autonomy (mins.) |
| 3 | Inverter voltage (V) | 6 | Inverter Load (A) | 9 | UPS Temperature (°C) |

REAR PANEL DETAILS

6 kVA Model

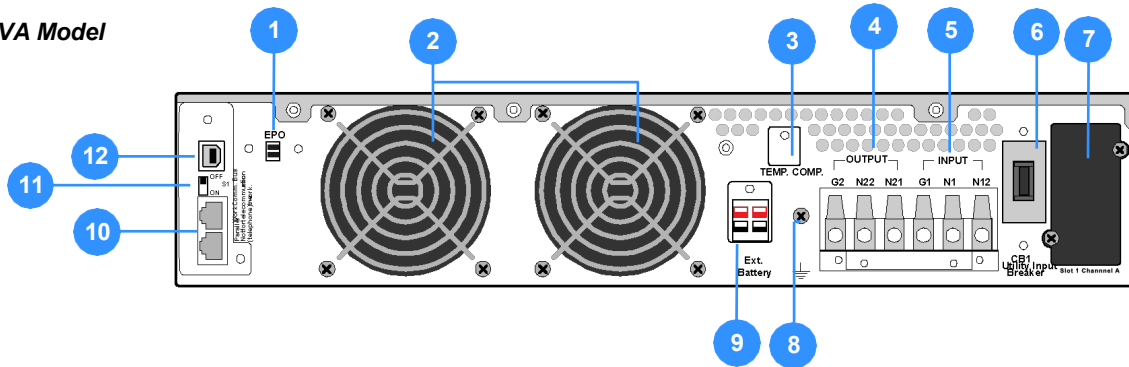

| | | | | | |
|---|-------------------------------------|---|-----------------------------------|----|-----------------------------------|
| 1 | Emergency Power Off (by drycontact) | 5 | Input terminals | 9 | External battery power socket |
| 2 | Extractor fan | 6 | Utility input breaker | 10 | Parallel bus communication cables |
| 3 | Temperature compensation (option) | 7 | Optional communications card slot | 11 | Parallel switch S1 |
| 4 | Output terminals | 8 | External battery cable earth | 12 | USB Port |

10 kVA Model

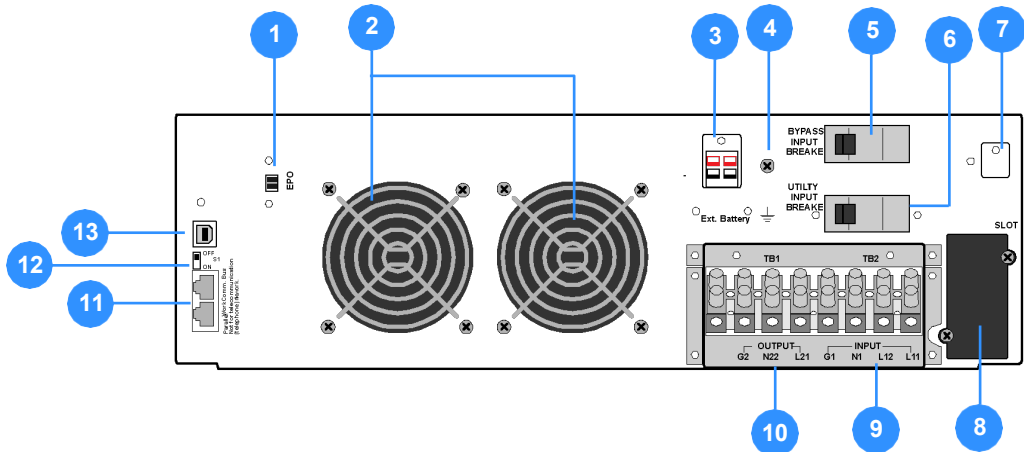

| | | | |
|---|--------------------------------------|----|---|
| 1 | Emergency Power Off (by dry contact) | 8 | Optional communications card slot |
| 2 | Extractor fan | 9 | Input terminals (split bypass line input) |
| 3 | External battery power socket | 10 | Output terminals |
| 4 | External battery cable earth | 11 | Parallel bus communication cables |
| 5 | Bypass input breaker | 12 | Parallel switch S1 |
| 6 | Utility input breaker | 13 | USB Port |
| 7 | Temperature compensation (option) | | |

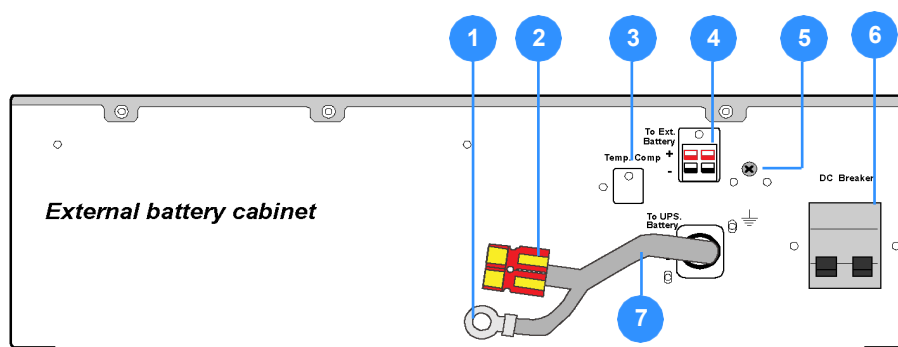

| | | | |
|---|-----------------------------------|---|---------------------|
| 1 | Battery power cable earth lead | 5 | Safety earth (PE) |
| 2 | Battery power cable plug | 6 | DC Circuit breaker |
| 3 | Temperature compensation (option) | 7 | Battery power cable |
| 4 | External battery power socket | | |

COMMUNICATION OPTIONS

The UPS can communicate with various external devices and systems, including:

- Hard-wired external Emergency Power Off (EPO) facility.
- A USB port to allow serial communication with monitoring software installed on a remote PC.
- Optional card slot that can be used with:
 - an intelligent CS141 card for local or area network UPS monitoring and control OR
 - a Dry Contact relay card to provide volt-free signalling that can be integrated into an external alarm monitoring or building management system.

All communication ports, including the optional cards, can be active and used simultaneously to monitor the UPS status; however, only one communication interface at a time can control the UPS. This is determined on a priority basis, with the higher priority interface gaining control.

The interface control priorities are as follows:

- EPO input port
- Optional interface card
- Optional USB port

Emergency Power Off (EPO)

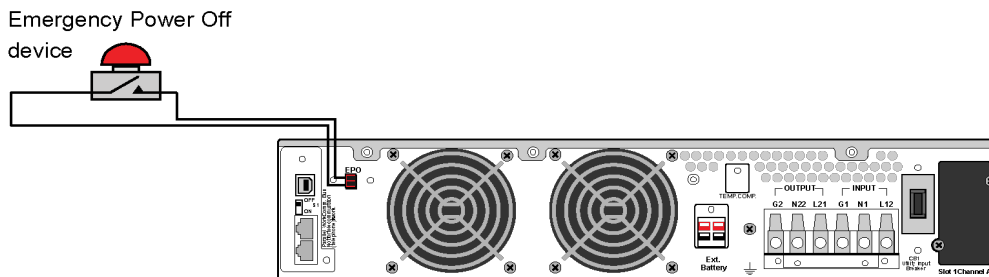

The Emergency Power Off (EPO) option allows you to turn off the UPS using an external switch or contact that is hard-wired to the EPO terminal block on the back of the UPS. By default the external circuit should be a 'normally open' contact that will power-off the UPS when the contact is closed; however this can be reversed through software configuration. The EPO connection should be made using a screened, single pair cable (0.5mm²) with a maximum length of 100 metres.

When the EPO circuit is activated the UPS output will turn off, removing power to the load, but the battery charger will remain operational to sustain battery charging. Although an EPO alarm is shown on the LCD display, you can still scroll through the UPS input, battery and output metering.

USB Computer interface

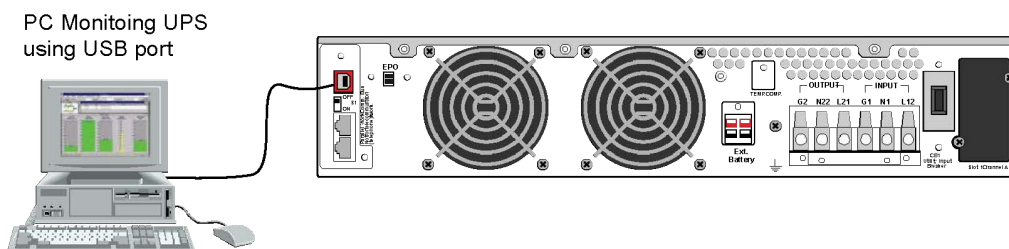

When used in conjunction with suitable software, the USB ports allow the connected PC to continuously monitor the input mains voltage and UPS status, and display appropriate operating data and messages.

The USB connector can be connected to a PC using standard USB cable with a maximum length of 3 metres.

CS141 /SNMP adapters

CS 141 card fitted
in the Interface slot

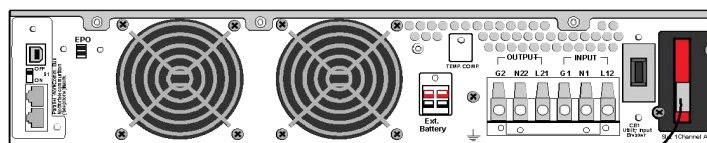

Simple Network Management Protocol (SNMP) is a world-wide, standardised communication protocol that can be used to monitor any network-connected device via a simple control language and display the results in a browser-based application. The software agent built in to the CS141 adapter card makes the UPS data available in this SNMP format which can then be utilized by a number of UPS management software applications.

The card contains a serial interface, which can be connected directly to a computer's serial port, and an RJ-45 connector which allows it to be connected to a network using a standard CAT-5 cable. The SNMP adapter can be configured via Telnet, http (browser) or serial connection. For normal operation, at least one Ethernet network connection is necessary.

Once installed, the UPS-Management software agent, which is already installed in the card, monitors the UPS operation and outputs its data in SNMP format to the connected network. The card enables automated generation of event/alarm emails, server controlled shut down (with optional licenses) and other tasks, and can also be integrated with BMS software over a local area network (LAN) for SNMP or Modbus information over IP. Rehlko offer monitoring software with SNMP functionality for Novell, OS/2, and Windows that run both on INTEL and on ALPHA, DEC VMS and Apple.

RCCMD

RCCMD (Remote Console Command Module) for 'multi-server shut down' is an independent software module intended for transmitting and receiving 'remote commands'. Using the 'RCCMD send' function, the SNMP adapter can send status messages to connected users or initiate automatic shut down throughout the whole network. Our CS141 SNMP adapters are fully compatible with RCCMD.

Dry Contact card

DCE-C is an UPS management product with 6 relay output contacts for monitoring the status and 3 input contacts as a shutdown UPS command. The volt-free signalling outputs can be integrated into an external alarm monitoring panel or building management system.

All the output connections for R1 to R6 are switched by independent relays and can be configured either N/C or N/O. Details for configuration are provided in the documentation that accompanies the card.

Relay terminals are rated up to 40VDC,800mA.

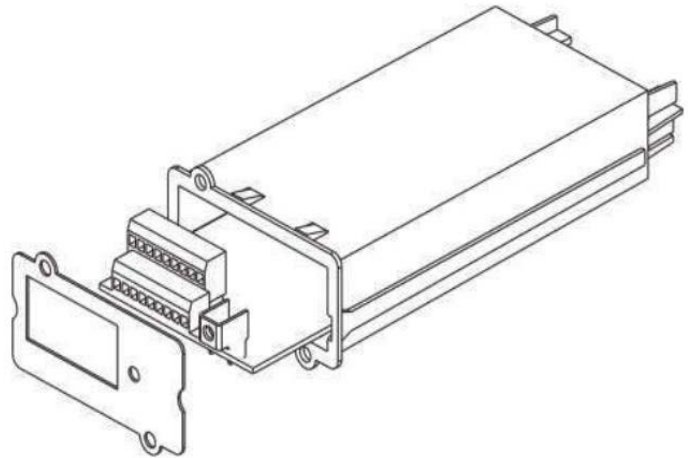

Dry Contact card (DCE)

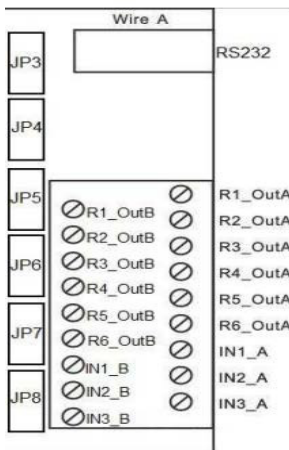

Pin outs

The pin outs are shown on the left and function as table below.

| Pin | Function |
|-----------------|--|
| R1_OutB/R1_OutA | UPS on Bypass Mode |
| R2_OutB/R2_OutA | Utility Abnormal/Utility Normal |
| R3_OutB/R3_OutA | Inverter On |
| R4_OutB/R4_OutA | Battery On |
| R5_OutB/R5_OutA | Battery Bad or Abnormal |
| R6_OutB/R6_OutA | UPS Alarm |
| IN1_A/IN1_B | Remote Shutdown by Utility status |
| IN2_A/IN2_B | Energy saving shutdown by Utility status and load percentage |
| IN3_A/IN3_B | Energy saving shutdown by Utility failure time |
| RS232 | Communicate to PC for setting or firmware upgrade |

INSTALLATION PLANNING

The following *guidelines* should be taken into account when planning a suitable location and environment for the Rehiko PW 1000 (6-10kVA) UPS installation.

Choosing a suitable installation location

Environment considerations:

- Avoid locations with possible high ambient temperature, moisture and humidity:
 - temperature should be between 0°~40°C.
 - the battery temperature must be maintained at 20°C to ensure its lifespan is not reduced
 - humidity should be less than 95% non-condensing
- An adequate cooling air flow must be available if necessary to sustain a suitable temperature
- Ensure no dust or corrosive/explosive gasses are present

Other considerations:

- The UPS is not designed for outdoor use
- The location must be vibration free, clean, dry and free of excessive dust
- If the UPS system is installed as a Tower system, the supporting surface should be non-flammable
- The UPS must not be installed in a corrosive environment or in the vicinity of flammable items
- Local fire protection standards must be respected
- The ventilation grills at the front of the UPS and extractor fans at the rear of the UPS must not be obstructed
- The UPS mains power supply must be readily available
- The UPS and battery must be installed with the clearances illustrated below. If it is to be installed as a Tower system the connected cables must be of an adequate length to allow the UPS to be manoeuvred for maintenance access if necessary, as shown.

Mounting the equipment

Mounting hardware

The UPS and battery enclosures can be rack-mounted in a standard 19-inch cabinet or installed as a Tower system. All the hardware required to install the units as a Tower system, such as 'feet' and mechanical linkages, are included as part of the UPS/Battery packaging. For rack installation, an optional adjustable mounting rail system that can be fitted to cabinets of up to 1000 mm depth can be purchased from UPS Limited if required.

The recommended installation clearances are shown in the following diagrams.

Tower installation

The total width of the system hardware can range from 220 mm, for a 6 kVA UPS cabinet with a single battery cabinet, up to a possible 9240 mm for 10kVA unit connected to 6 battery cabinets. Only one battery cabinet is shown in the following clearance diagram.

The illustrations on the left of the Tower clearance diagram show the clearances necessary to provide adequate cooling during normal operation, and those on the right show the clearances required to access the system for maintenance. If the specified 'maintenance' clearance is not readily available, the cables connected to the UPS should be made sufficiently long to allow the UPS to be manoeuvred to a position where an adequate clearance is obtainable.

Rack installation

When the UPS is rack-mounted, a minimum of 200mm should be available between the rear of the UPS and the back of the rack cabinet to enable adequate ventilation and provide space for cabling. The rack cabinet must have a ventilated door and a minimum clearance of 1000 mm must be provided at the front and rear of the cabinet to allow full UPS access for installation and maintenance, although we recommend that this is increased where possible.

Due to weight considerations we recommend that the UPS is installed in the bottom of the rack, with the UPS placed above the battery cabinet(s).

Tower installation clearances

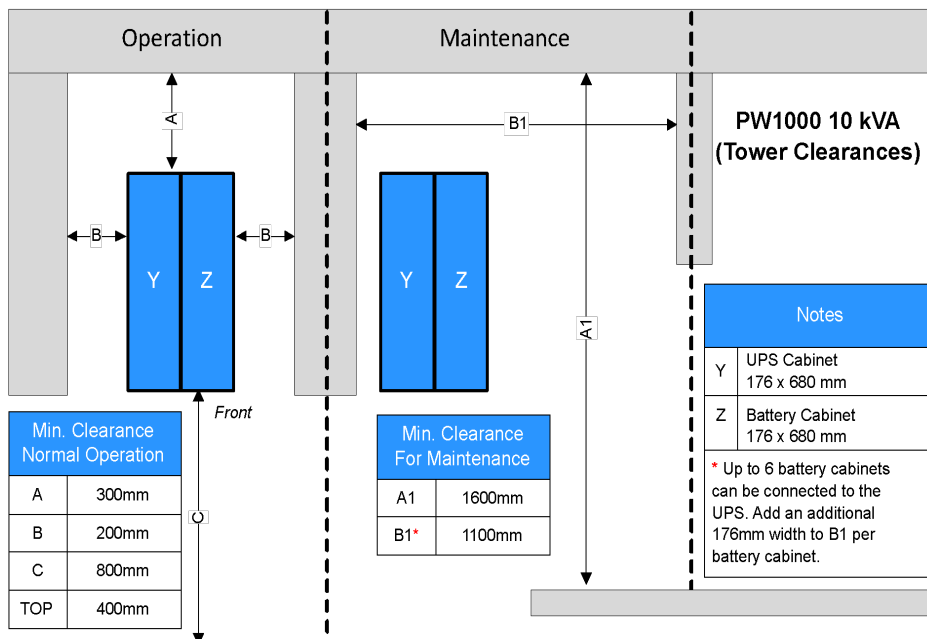
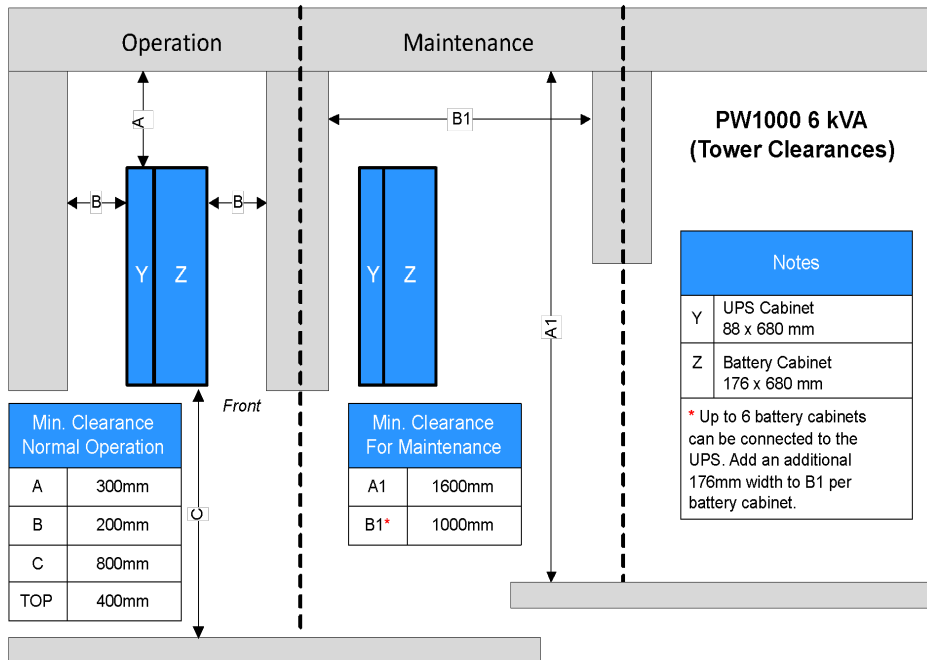

Rack installation clearances

