



REHLKO *PW* 1000

Standalone tower or rack mount single-phase uninterruptible power supply with internal or external batteries

(6-10 kVA)

User Manual

Document Control	1
Useful Contacts	1
1: Safety	1
1.1 Description of symbols used in this manual	1
1.2 User precautions	1
1.3 Important safety notes	2
1.4 Storage instructions	2
2: General Description	3
2.1 Introduction	3
2.1.1 Advanced design features	3
2.1.2 Rehiko PW 1000 (6-10kVA) model range	4
2.2 UPS Operating principles	4
2.2.1 Basic block diagram	4
2.2.2 UPS module operating modes	6
2.2.3 UPS System operating modes	7
2.3 Operator control panel	9
2.3.1 LED Indicators	9
2.3.2 Operator keypad	10
2.3.3 LCD Display	10
2.4 UPS Rear view	12
2.4.1 Communication Ports	12
2.5 Battery cabinet	14
2.6 Warranty	15
2.7 Extended Warranty	15
2.8 Additional Service/Maintenance Support	15
3: Installation	16
3.1 Unpacking the UPS equipment	16
3.2 Selecting a suitable installation location	16
3.3 Clearances	17
3.3.1 Rack-mounted installation	17
3.3.2 Tower installation	19
3.4 Hardware installation	19
3.4.1 Hardware accessories pack	19
3.4.2 Tower assembly hardware	20
3.4.3 Rack installation hardware	20
3.5 Electrical installation	24
3.5.1 Safety warnings:	24
3.5.2 Cable rating	24
3.5.3 Cabling procedure	24
3.6 External battery charger installation	25
3.6.1 Installation procedure	26
3.7 Initial UPS power-up and commissioning	27
4: Operation	28
4.1 Introduction	28
4.2 UPS start-up procedures	29
4.2.1 How to start the UPS (from utility mains)	29
4.2.2 How to start the UPS (from battery)	30
4.2.3 How to monitor the UPS input/output operating conditions	31
4.3 UPS shut down procedures	32
4.3.1 How to turn off the UPS (from ON INVERTER or ECO Mode)	32
4.3.2 How to turn off the UPS (from ON BATTERY Mode)	32
4.4 Manual load transfer between inverter and bypass	32
4.5 Functions menu	33
4.5.1 How to disable the alarm buzzer operation	33
4.5.2 How to perform a battery test	33

4.5.3	Functions menu	34
4.5.4	Operating parameters setting menu	35
5:	Maintenance	36
5.1	Introduction	36
5.2	Scheduled maintenance	36
5.2.1	Preventative maintenance inspection	36
5.2.2	Battery maintenance and testing	36
6:	Troubleshooting	38
6.1	Introduction	38
6.2	Fault identification	38
6.2.1	Error codes	38
6.2.2	Audible warning alarm	38
6.2.3	Warning symbols	39
6.3	Troubleshooting a fault condition	39
6.4	Troubleshooting an operational problem	40
6.5	UPS Fault handling	40
6.5.1	Output load short circuit when the output supply is via inverter	41
6.5.2	Output short-circuit when the output supply via the bypass line	41
6.5.3	Inverter/internal over-temperature	41
6.5.4	Inverter over-current and output voltage out of tolerance	41
6.6	UPS System reset	41
7:	Options	42
7.1	Communications options	42
7.1.1	Emergency Power Off (EPO)	42
7.1.2	USB Computer interface	43
7.1.3	CS141 /SMNP adapters	43
7.1.4	Dry Contact card	44
8:	Specification	45
8.1	UPS CABINET	45
8.2	BATTERY CABINET	47

1 Safety

1.1 Description of symbols used in this manual



WARNING: The warning symbol is used where there is danger of an electrical shock, equipment damage or personal injury.



CAUTION: The caution symbol is used to highlight important information to avoid possible equipment malfunction or damage.

1.2 User precautions



WARNING: Do not attempt to install this UPS system until you are satisfied that you have read and understood ALL the safety instructions and hazard warnings contained in this manual.



WARNING: Keep this manual with the UPS for future reference.



WARNING: DO NOT OPEN THE CASE. If you open the case of the UPS you will be exposed to dangerous voltages. The UPS does not contain any user-serviceable parts, so do not attempt to repair this unit yourself as doing so will void your warranty. If the UPS malfunctions it must be serviced or repaired by a trained engineer. Always contact your local service agent if repair is necessary.



WARNING: The UPS is equipped with an EMI filter, and to prevent a potential leakage current hazard the AC mains supply must be securely grounded at all times. You should double check that the UPS supply earth connection is properly grounded before you connect AC mains to the UPS.



WARNING: Rehlko will assume no responsibility or liability for accidents or injuries due to incorrect operation or manipulation of the UPS or peripheral equipment.



CAUTION: The PW 1000 (6-10kVA) is a Class A UPS product (according to EN 62040-3). In a domestic environment the UPS may cause radio interference and the user may be required to undertake additional measures.

1.3 Important safety notes



CAUTION: Please read the following notes carefully prior to installation and use.

1. The UPS warranty will become null and void if liquids are spilt on the UPS case, or foreign objects are dropped into the unit. Such mishaps could severely damage the UPS and present a shock hazard to anyone who touches the unit.
2. The ventilation grills on the UPS front panel must be kept free of obstruction at all times.
3. The UPS is must be installed in a sheltered and controlled environment away from direct sunlight. The operating temperature should be between 0~40°C (ideally 20°C) with relative humidity of 0~90%, non-condensing. Further details concerning the installation environment are included in the installation chapter of this manual.
4. Before installing the equipment you must check to ensure that the input voltage stated on the UPS data-plate on the back of the unit matches your local utility supply voltage.
5. The UPS warranty will be rendered void, and the manufacturer reserves the right to refuse replacement or compensation, if the UPS malfunctions due to:
 - Accidental damage to the UPS.
 - Damage or malfunction due to installing the UPS in an environment that does not meet the conditions specified in this manual.
 - Damage or malfunction due to improper installation, configuration or maintenance carried out by an unauthorised person.

1.4 Storage instructions

If you intend to store the UPS for an extended period, in a moderate climate, the batteries should be charged for 12 hours every 3 months by connecting the UPS to the utility supply. If the ambient temperature at the storage location is above 25°C, this should be carried out every 2 months.



CAUTION: Always switch off the UPS before moving it.

2 General Description

2.1 Introduction

Congratulations on your purchase of the Rehiko PW 1000 (6-10kVA) UPS.

High reliability, low operating cost and excellent electrical performance are just some of the highlights of this innovative UPS solution.

Rehiko specialises in the installation and maintenance of Uninterruptible Power Systems; and this UPS is just one example of our wide range of state-of-the-art power protection devices that will provide your critical equipment with a steady and reliable power supply for many years.

2.1.1 Advanced design features

By using the latest technological developments in power engineering, the Rehiko PW 1000 (6-10kVA) represents a new generation of transformerless UPS-System. Its advanced double conversion Voltage and Frequency Independent (VFI) topology responds fully to both the highest availability and environmentally friendly requirements, compliant with IEC 62040-3 (VFI-SS-111) standards. A full UPS specification is provided in Chapter 8 of this manual.

Following, are some of this unit's advanced design features:

- True online technology continuously supplies your critical applications with stable, regulated, transient-free pure sine-wave AC power.
- High-Frequency Transformerless technology and tower-convertible enclosure enables the UPS to be integrated into even the most difficult environments with space constraints.
- User-friendly design that permits simple and trouble-free installation. All units are supplied with input and output power cables as standard.
- Smart battery management system which extends the battery life span.
- Highly efficient PWM sine-wave technology yields excellent UPS efficiency. The high crest factor of the inverter handles peak inrush current loads and so avoids a need to upgrade to a UPS with a higher power rating.
- Compliant with various stringent international EMC standards for electromagnetic interference & protection.
- Selection of output voltages (200/208/220/230/240) available to match the UPS to local supply specifications or specific load voltage requirements.
- A selectable bypass voltage tolerance (low/high sensitivity) restricts the range of voltages that can be applied to the load when the UPS operates on bypass. The ranges are $\pm 15\%$ (low sensitivity) and $\pm 10\%$ (high sensitivity). For example, if the output voltage setting is 230V the bypass sensitivity Low range is 230V $\pm 15\%$.
- Selectable 50Hz or 60 Hz output frequency.
- Fully digitized control logic for better functionality and enhanced power protection. Digital signal processing (DSP) also provides efficient communication capabilities for enhanced remote control and monitoring flexibility.
- Active power factor correction (PFC) control function constantly maintains the UPS input power factor to >0.99 at 100% load, with resulting outstanding energy efficiency.
- Wide input voltage tolerance, from 110V~280V¹, allows the UPS to operate normally without draining the battery unnecessarily during significant mains voltage dips, which helps extend the battery service life.
- DC-start function permits the UPS to be started during a utility power failure if required.
- Overload protection system automatically switches the UPS to bypass mode if an overload occurs and automatically switch back to inverter mode once the overload condition ceases. Should the output become short-circuited, the UPS puts the system in stand-by mode, provides visible and audible alarms, and turns off the output supply automatically until the short circuit situation is resolved manually.

1. Depending on the prevailing load

2.1.2 Rehlko PW 1000 (6-10kVA) model range

The PW 1000 UPS series comprises modules ranging from 1 kVA to 10 kVA. This manual covers the 6.0 kVA and 10 kVA models only.

The Rehlko PW 1000 (6-10kVA) UPS can be mechanically configured as a floor-standing tower unit or installed in a standard 19 inch rack. An accessory pack containing all the parts necessary to configure the unit for either type of installation is supplied with the UPS.

The UPS batteries are installed in a separate battery cabinet and up to six battery cabinets can be connected in tandem to increase the UPS autonomy time. The battery cabinet design compliments the UPS cabinet and they can be connected together mechanically to form a single unit when installed as a tower system – see Chapter 3 (Installation) for mechanical configuration details.

Note: An external battery charger is required if three or more battery cabinets are connected to the UPS.

MECHANICAL DETAILS		6.0 kVA	10 kVA
Maximum output power	kVA (kW)	6.0 (6.0)	10 (10)
Dimensions UPS cabinet (WxHxD)	mm	440 x 88(2U) x 680	440 x 132(3U) x 680
Dimensions UPS cabinet with battery cabinet (WxHxD)	mm	440 x 222(5U) x 680	440 x 264(6U) x 680
Weight UPS cabinet only	kg	24 kg	45 kg
Weight UPS cabinet plus 1x battery cabinet	kg	52 kg	96 kg
Sound level (@ 1 metre)	dBA	≤60	≤60

2.2 UPS Operating principles

2.2.1 Basic block diagram

Figure 2.1 illustrates a functional block diagram of the PW1000 UPS module and shows that it is a self-contained UPS system comprising rectifier, inverter and static switch power sections – the battery is housed in a separate enclosure. The 6.0 kVA and 10 kVA models are functionally identical apart from the input power connections, where the 10 kVA features a separate bypass mains connection together with a bypass circuit breaker. This allows the UPS bypass circuit to be connected to a dedicated mains supply, if desired, and is described fully in the installation chapter of this manual.

EMI Filters

The UPS has an input and output EMI filter to reduce the effects of electromagnetic noise generated by the UPS on other adjacent equipment – e.g. reduces external radio interference.

Battery charger

The battery charger is powered directly from the utility mains supply and charges the UPS battery whenever the input supply is available and the input circuit breaker is closed. The charger feature an intelligent, multi-stage control mechanism which ensures the battery is recharged quickly following a deep discharge cycle, followed by closely controlled maintenance (float) charging to extend the battery life.

AC/DC (PFC) Converter

As its name suggests, the AC/DC Converter converts the utility mains input into a controlled DC supply that is suitable to power the inverter. The converter uses a leading-edge switched-mode technique which produces an input power factor of almost unity over its full operating range (0.99 at full rated linear load) and thereby maximises the UPS efficiency.

The converter can satisfy the inverter's DC power demands over a mains voltage range of between 110V~300 VAC which means that the battery is not called upon during power dips (brown-outs), thereby maximising battery life and availability.

DC/DC Boost converter

If the utility mains supply fails, or falls outside its prescribed 110~280 VAC range, the DC/DC Boost Converter turns on and boosts the battery voltage to a level suitable for use by the inverter. It then provides a regulated DC output while the battery voltage decays during discharge and includes voltage and current monitoring, and overload protection.

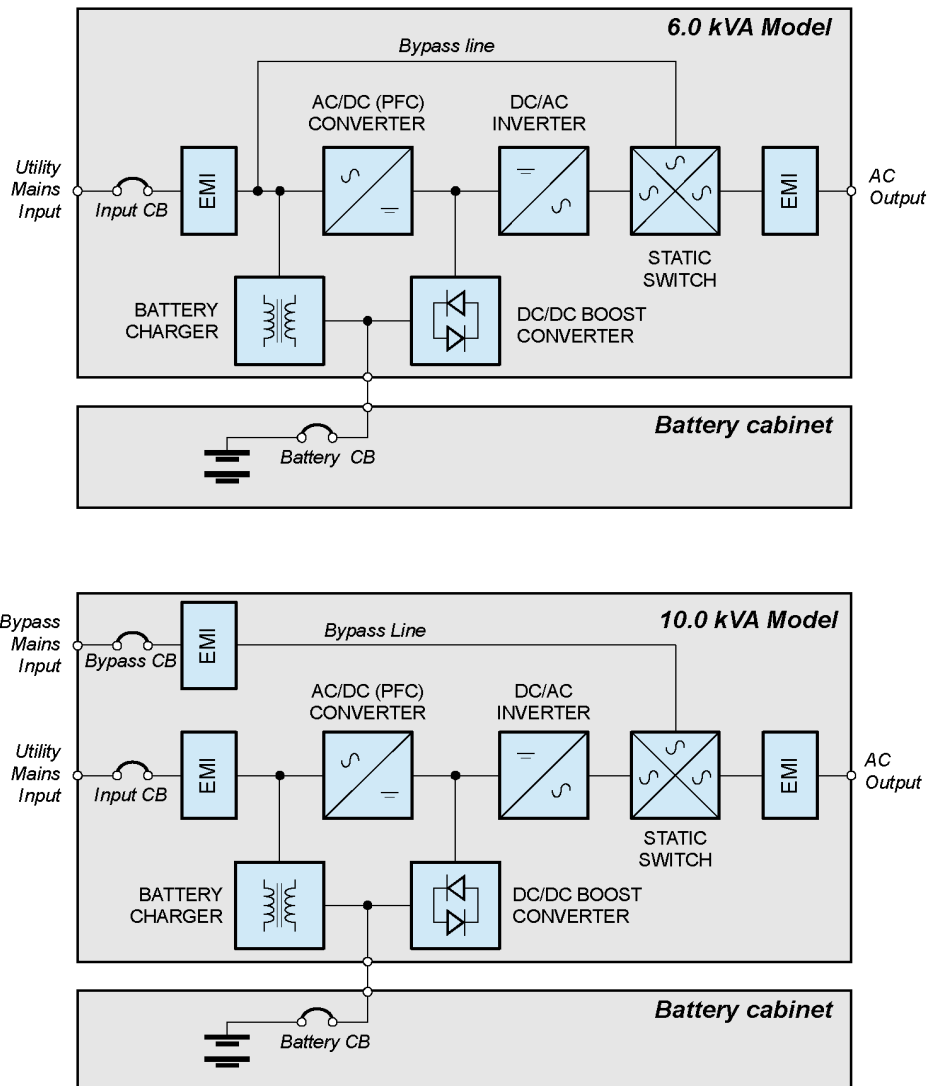

Figure 2.1 UPS Functional block diagram

DC/AC Inverter

The inverter converts the DC voltage connected to its input, from either the AC/DC converter or from the battery via the DC/DC converter, to a sinusoidal AC voltage that is suitable to power the connected load equipment. The control logic associated with the inverter power block is substantial, and in addition to controlling the output voltage it provides various levels of overload protection, frequency regulation and synchronisation, and output voltage error detection.

Static switch

The static switch provides a means of connecting the UPS AC output (load) to either the inverter or the bypass line and the control logic within this power block will transfer the load to the bypass supply automatically in the event of a UPS overload or inverter malfunction. It is also possible to transfer the load between the inverter and bypass line manually via the UPS control panel. Note that a 'no-break' transfer can take place only if the inverter output is fully synchronised to the bypass line.

2.2.2 UPS module operating modes

For reasons of simplicity and clarity the EMI filters and bypass mains input are not shown in this series of diagrams.

ON-INVERTER operation

This is the 'normal' UPS operating mode:

- The battery charger provides controlled battery charging.
- The AC/DC converter converts the utility mains supply to a controlled DC bus suitable for powering the inverter.
- The inverter converts the AC/DC supply suitable for powering the load.
- The 'inverter side' of the static switch is turned on and connects the inverter output to the UPS AC Output terminals.

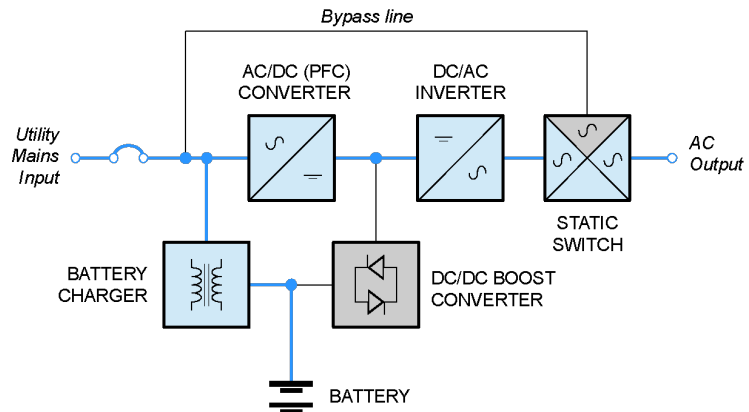

Figure 2.2 ON-INVERTER operation

ON BATTERY operation

The UPS switches to this operating mode automatically during mains failure

- The AC/DC converter turns off and the battery provides the inverter DC input via the DC/DC boost converter.
- The DC/DC boost converter presents the inverter with a controlled input voltage as the battery discharges.
- The inverter converts the DC/DC converter output to back to an AC supply suitable for powering the load.
- The 'inverter side' of the static switch connects the inverter output to the UPS AC Output terminals.

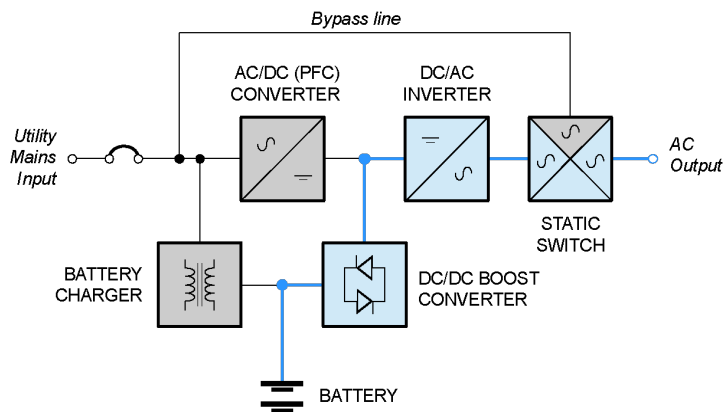

Figure 2.3 ON-BATTERY operation

ON BYPASS operation (OFF/ fault)

The UPS switches to this mode when it is turned OFF or if there is a UPS fault.

- All UPS power blocks turn off.
- The battery charger remains active if the utility mains is available.
- The 'bypass side' of the static switch connects the UPS bypass line to the AC Output terminals.

When operating in this mode, the load is unprotected from utility power disturbances.

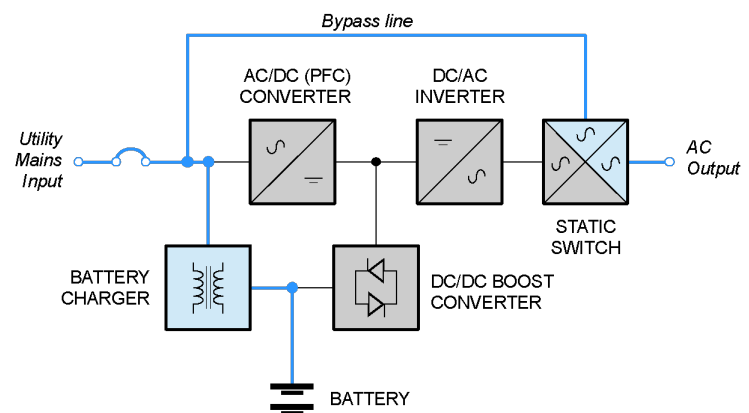

Figure 2.4 ON-BYPASS operation (Off/ fault)

ON BYPASS operation (ECO / overload)

The UPS operates in this mode:

1. When the UPS is used in 'ECO' mode
2. If there is an output overload which exceeds the UPS load/time characteristics.
3. For a brief period during normal UPS start-up/ shut-down procedures.
4. In this mode of operation:
 - The battery charger provides controlled battery charging.
 - The AC/DC converter and inverter are turned on and operating normally (the inverter is effectively 'on stand-by').
 - The 'bypass side' of the static switch connects the UPS bypass line to the AC Output terminals.

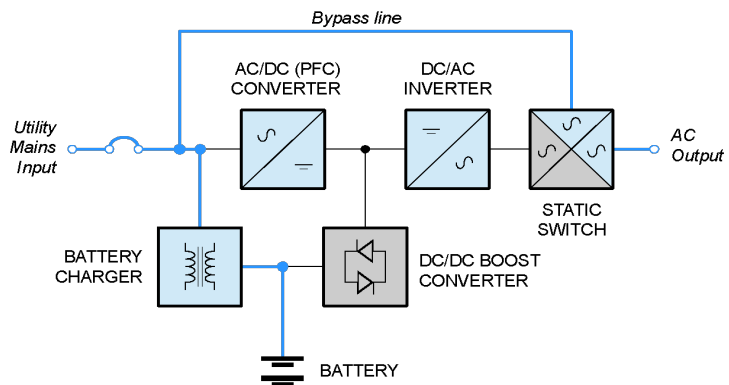

Figure 2.5 ON-BYPASS operation (ECO)

Note: When operating in this mode the load is unprotected from utility power disturbances. If the utility mains (bypass line) supply fails the UPS will transfer to ON BATTERY mode, but there will be a brief AC output power break while the static switch transfers the output to the inverter-side.

2.2.3 UPS System operating modes

Paragraph 2.2.2 described the various UPS Module operating modes; however, UPS systems are also generally categorised as being either 'On-line' or 'Off-line' systems, and you can configure the Rehlko PW 1000 (6-10kVA) to operate in either of these modes.

On-line UPS system operation

When the Rehlko PW 1000 (6-10kVA) is configured to operate as an 'On-line' system it normally operates in the ON INVERTER mode, as shown in Figure 2.2, and in the event of a utility supply failure it changes to ON BATTERY mode without affecting the UPS output – i.e the changeover is totally transparent at the load. The UPS then continues to supply up to its rated output until the battery discharges to a low cut-off point, at which time it shuts down in a controlled manner. An alarm warns the operator that the battery is discharging to enable any necessary intervention to protect the load integrity.

During its the ON INVERTER operation the static switch transfers the load to the static bypass line (ON BYPASS mode) automatically if the UPS experiences an inverter fault or overload. This is performed without any interruption on the UPS output (transfer time = 0) provided the inverter and bypass supplies are synchronised.

If the transfer is due to a UPS overload the static switch will transfer the load back to the inverter if the overload clears, and the UPS will return to its normal ON INVERTER mode of operation.

An 'On-line' system provides the highest degree of load protection, especially in the event of a utility mains disturbance, and we always recommended its use if the critical load, such as a computer system, will not tolerate even a very brief supply interruption.

Off-line UPS system operation (single module installation only)

When the Rehlko PW 1000 (6-10kVA) is used as an 'off-line' UPS it is configured to normally operate in its ON BYPASS mode (Figure 2.4), with the load supplied via the bypass line. However the AC/DC converter and battery charger are still powered up to maintain battery charging, and the inverter section is turned on but operating on standby.

If the bypass supply fails, the inverter automatically activates and the static switch transfers the load from the bypass line to the inverter within 3 to 5 milliseconds – so the UPS now operates in its ON INVERTER mode. If the utility mains supply is unavailable when the transfer-to-inverter takes place, the inverter will operate from battery power (ON BATTERY mode) and the UPS will shut down when the battery is fully discharged.

When the bypass supply returns to normal, the load re-transfers back to the static bypass line and the inverter returns to its standby operation.

Operating in this mode is slightly more energy efficient than when operating in the 'On-line' mode due to the reduced AC/DC converter and inverter losses during normal system operation. For this reason this is therefore sometimes referred to as the "ECO" (economy) mode. However this mode is recommended only if the connected load can tolerate a power interruption of up to 3~5 ms during the transfer period.



WARNING: The 'On-line' mode should always be used for critical load protection.

Frequency changer operation

In addition to the 'On-line' and 'Off-line' modes, the Rehlko PW 1000 (6-10kVA) can also be used in a 'frequency changer' role where the inverter output is produced at a different frequency from that of the utility supply – for example 50 Hz utility mains input with 60 Hz UPS output, or vice versa.

When operating as a frequency changer it is clearly not possible to switch the load between the inverter and bypass, due to their differing frequencies, so the bypass side of the static switch is electronically disabled by the UPS control logic. This also means that the static bypass line is not available to assist in clearing an output overload. For this reason, in order to provide some overload headroom, we recommended that the UPS is operated to a maximum 75% of its rated load capacity if the input voltage range is 176-280 VAC and 50% load capacity if the input voltage range is set to 160-280 VAC.

2.3 Operator control panel

The UPS is controlled from the operator control panel located on the front of the unit.

Led indicators

Indicate the UPS input and output power status, together with a general fault warning.

LCD Display

Indicates the UPS operating mode together with the input, output, and battery supply parameters. It also displays error messages and UPS set-up data via a system of selection menus.

Operator Keypad

The keypad contains 6 keys that are used to navigate the UPS control menu and turn the UPS OFF /ON.

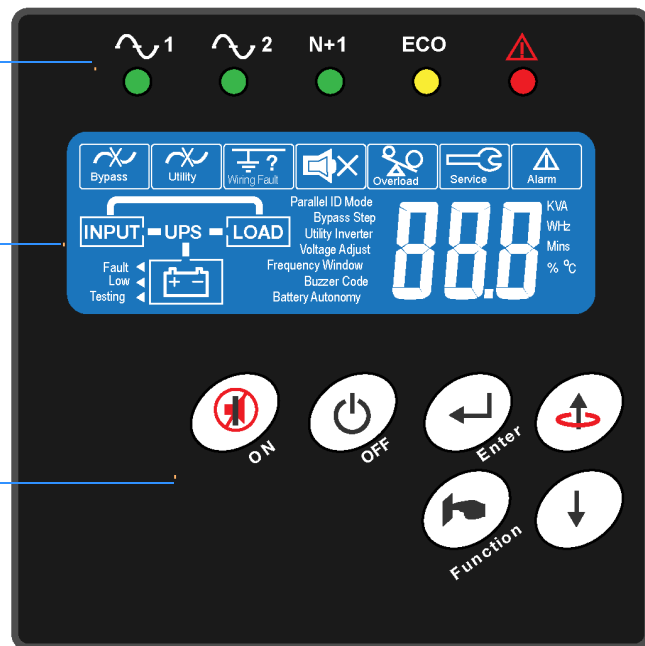

Figure 2.6 Operator control panel

2.3.1 LED Indicators



Utility mains supply status

This led shows the status of the utility mains supply. It indicates solid green if the utility supply is within 160~280 VAC and flashes if the supply falls to 120~159 VAC. The led extinguishes if the voltage falls below 120 VAC to indicate a utility mains supply failure.



Bypass mains supply status

This led shows the status of the bypass mains supply. The bypass mains terminals are internally linked to the utility mains terminals in the 6 kW model and this indicator therefore mimics the utility mains supply status indicator described above. In the 10 kW UPS model the bypass mains terminals can be connected to a dedicated mains supply, in which case this led indicates the bypass mains supply status and operates on the same voltage thresholds described above for the utility mains supply status led.

N+1

N+1 Redundancy status



ON indicates that the UPS system is able to operate in redundancy mode.
OFF indicates that the UPS system is operating in 'capacity' mode.

ECO

ECO Mode



This led illuminates when the UPS is set to operate in the ECO (on bypass) mode.



UPS fault indication

This LED illuminates indicate the presence of a fault condition within the UPS that needs attention. It is usually accompanied by an audible alarm.

2.3.2 Operator keypad

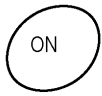

ON Button

This button is used to turn ON the UPS and activate certain functions when operated in combination with other buttons (as described later in this chapter). The button must be pressed for approximately one second to turn ON the UPS – accompanied by a double ‘beep’.



This symbol shows that the ON button is also used to cancel the audible alarm. When an alarm is cancelled, the audible warning will turn OFF but the alarm LED will remain ON if a fault is still present.

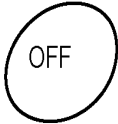

OFF Button

This button must be pressed for approximately one second to turn OFF the UPS – accompanied by a double ‘beep’.

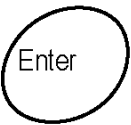

ENTER Button

The ENTER button is used to select a parameter from the UPS monitoring and configuration menus.



UP (BACK) Button

This button is used to navigate UP through the UPS menus, or change a menu parameter. It is also used with the ON button to manually transfer the UPS between ON INVERTER and ON BYPASS modes.

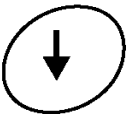

DOWN (NEXT) Button

During normal operation this button is used to scroll through the metered parameters shown on the LCD display. It is also used in conjunction with the ON button to access the UPS configuration menus.

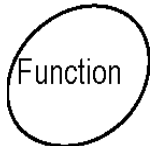

FUNCTION Button

This button is used to access the UPS configuration display menus.

2.3.3 LCD Display

The LCD display contains a row of warning symbols, a mimic diagram which indicates the active power path through the UPS, a battery status indicator and a multi-function 3-digit numerical display which can be selected to indicate a range of operating parameters. Each area is described below.

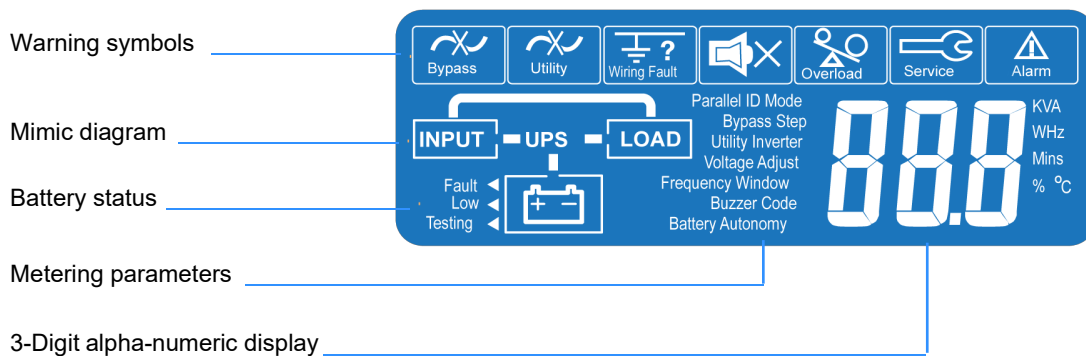

Figure 2.7 LCD Display

Warning symbols



Bypass input abnormal:

UPS fails to transfer to bypass, bypass abnormal in ECO mode



Utility input abnormal:

The utility mains supply is outside the UPS pre-set operating window



Wiring fault:

Site wiring problem such as reversed Line-Neutral connection



Alarm buzzer silent

The alarm buzzer has been silenced or disabled



Overload:

The UPS output is overloaded



Service:

The UPS is operating in its service mode (reserved for service engineers only)



Alarm:

An alarm condition is present. This remains active after the audible alarm is reset if the fault still exists.

Mimic diagram

The LCD Mimic diagram indicates the existing power flow through the UPS. The INPUT, UPS, LOAD and BATTERY symbols are permanently shown on screen and their interconnecting lines appear, or disappear, depending on the UPS mode of operation – see the table below.

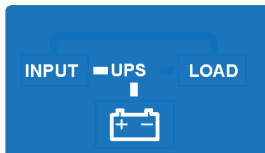

UPS OFF

This mimic is displayed when the utility power is first applied or the UPS is turned OFF. It shows that the battery is being charged from the utility supply (INPUT) but the LOAD is not connected to the UPS, and is therefore unpowered.

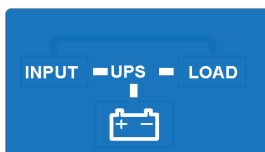

ON INVERTER

This mimic is displayed during normal UPS operation. It shows the battery being charged from the utility supply (INPUT) and the LOAD is connected to the UPS output (inverter) and is therefore being supplied with processed, backed-up power.

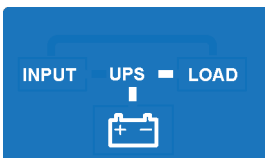

ON BATTERY

This mimic is displayed if the utility supply fails. It shows the battery now providing the UPS (inverter) and LOAD power. The battery will sustain the UPS output until it is fully discharged, whereupon the UPS will shut down.

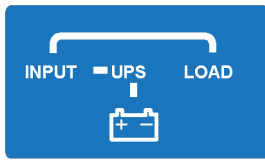

ON BYPASS

This mimic is displayed if the UPS develops a fault, or is overloaded, whereupon the LOAD is transferred to the bypass line and connected directly to the utility supply (INPUT). The battery will remain on charge if the UPS battery charger is healthy.

Battery status indicators

There are three 'flags' to the left of the battery icon which indicate the battery status.

Fault

Indicates a battery fault and is normally accompanied by an illuminated alarm warning symbol and an audible warning. An error code will be shown on the LCD 3-digit alphanumeric display which helps with fault identification.

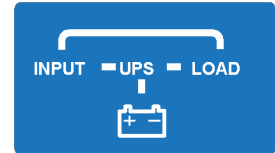

Low

When the UPS is operating ON BATTERY the Low flag will turn on when the battery is nearing its end of discharge. This is accompanied by an increase in the number of short successive beeps produced by the alarm buzzer.

Testing

The Testing flag flashes when a battery test is operation – see paragraph 4.5.2.

Meter Display

When the UPS is turned ON, you can use the DOWN and UP buttons to scroll through the measurement display screens. The display sequence is as numbered in the table below and loops around in either direction.

1	Utility Voltage (V)	4	Inverter Frequency (Hz)	7	Battery Voltage (V)
2	Utility Frequency (Hz)	5	Inverter Load %	8	Battery Autonomy (mins)
3	Inverter voltage (V)	6	Inverter Load (A)	9	UPS Temperature (°C)

2.4 UPS Rear view

2.4.1 Communication Ports

Several communication options can be connected to the Rehlko PW 1000 (6-10kVA). These are described briefly below with further details provided in Chapter 7 (Options).

USB port

A USB type B socket allows the UPS to be connected to a PC using a standard USB peripheral interface cable and can be used in conjunction with UPS monitoring and shut down software (not supplied). The USB communication protocol complies with USB version 1.0 (1.5 Mbps) and USB HID version 1.0.

Emergency power off (EPO)

If an external emergency power off (EPO) facility is required the external circuit must be connected to the two pin plug located on the rear panel. The EPO input requires a normally-open contact which closes to activate the EPO function. If the UPS is shut down by the EPO input (closed), it has to be restarted manually after the EPO input is removed (opened).

Optional interface cards

An optional SNMP/ CS141 interface card can be fitted in the card slot to enable the UPS to be integrated into a network monitoring and control system.

Parallel bus communication ports

Not connected in a single module installation.

6 kVA Rack Model

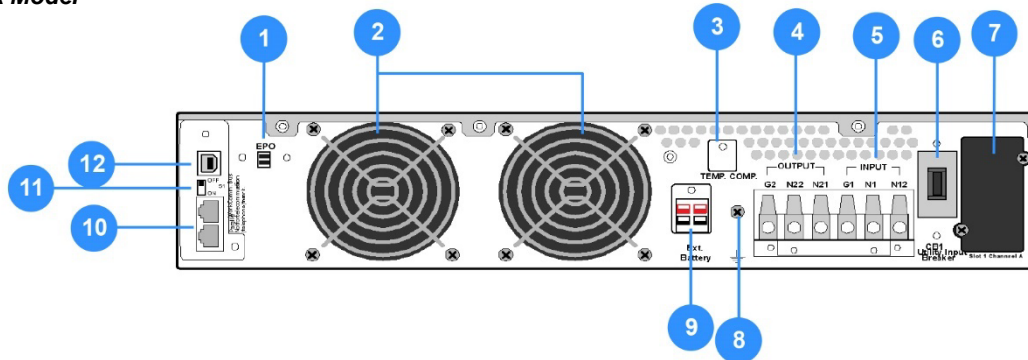

- | | |
|--|---------------------------------------|
| 1 Emergency Power Off (by dry contact) | 7 Optional communications card slot |
| 2 Extractor fan | 8 External battery cable earth |
| 3 Temperature compensation (option) | 9 External battery power socket |
| 4 Output terminals | 10 Parallel bus communication cables |
| 5 Input terminals | 11 Parallel switch S1 (OFF, not used) |
| 6 Utility input breaker | 12 USB Port |

10 kVA Rack model

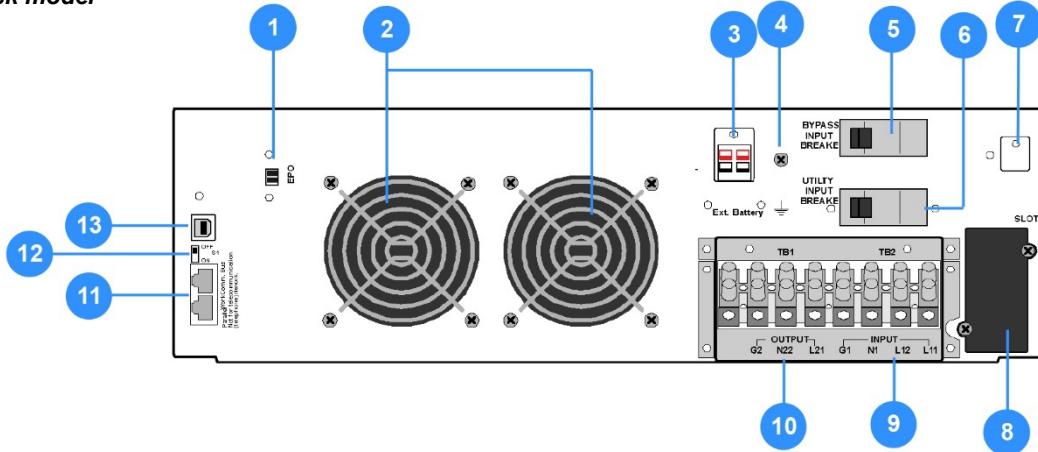

- | | |
|--|---------------------------------------|
| 1 Emergency Power Off (by dry contact) | 8 Optional communications card slot |
| 2 Extractor fan | 9 Input terminals |
| 3 External battery power socket | 10 Output terminals |
| 4 External battery cable earth | 11 Parallel bus communication cables |
| 5 Bypass input breaker | 12 Parallel switch S1 (OFF, not used) |
| 6 Utility input breaker | 13 USB Port |
| 7 Temperature compensation (option) | |

Figure 2.8 Rear panel detail

2.5 Battery cabinet

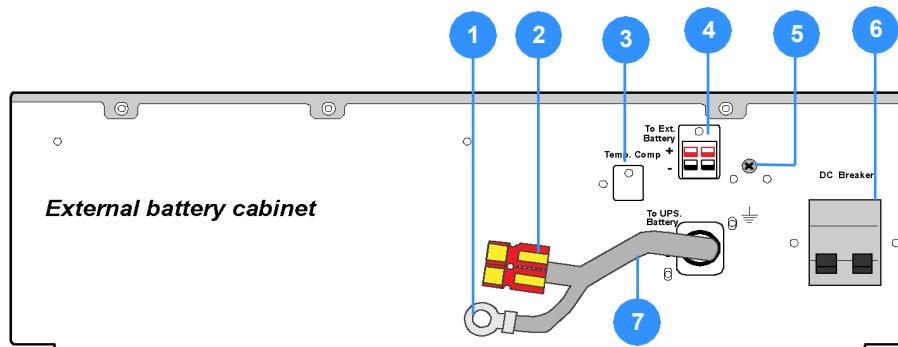

- | | |
|-------------------------------------|--------------------------------|
| 1 Battery power cable earth lead | 5 External battery cable earth |
| 2 Battery power cable plug | 6 DC Circuit breaker |
| 3 Temperature compensation (option) | 7 Battery power cable |
| 4 External battery power socket | |

Figure 2.9 External battery cabinet rear panel details

The UPS batteries are contained in a purpose-designed, matching cabinet which can be installed as a stand-alone unit or mechanically attached to the UPS cabinet to form a single tower assembly. When the battery cabinet is rack-mounted it should be installed immediately below the UPS cabinet, and preferably located in the bottom of the rack.

Referring to Figure 2.9, the 4-pin battery power cable emerging from the back of the battery cabinet should be connected to the external battery power socket on the back of the UPS cabinet. The cable also contains a ‘flying’ earth lead which must be connected to the external battery earth terminal on the back of the UPS cabinet, located adjacent to the external battery power socket.

Up to six battery cabinets can be connected to the UPS cabinet. The battery charger within the UPS cabinet can provide the charging requirements for two battery cabinets, but if three or more battery cabinets are connected an external battery charger is required.

Where two (or more) battery cabinets are installed they are connected in a daisy-chain fashion with the battery power cable of the first cabinet connected to the external battery power socket on the back of the second cabinet; and the battery power cable of the second battery cabinet then connected to the UPS cabinet. If an external battery charger is needed, its output cable is connected to the external battery power socket on the back of the first cabinet

2.6 Warranty

The Rehiko PW 1000 (6-10kVA) UPS is supplied with a limited warranty that the UPS and its component parts are free from defects in materials and workmanship for a period of one year from the date of original commissioning, or fifteen months from the date of original delivery, whichever is the sooner. This warranty is the only warranty given and no other warranty, express or implied, is provided.

This warranty is invalidated if the UPS is used without having first been commissioned by a fully trained and authorised person. This warranty does not apply to any losses or damages caused by misuse, abuse, negligence, neglect, unauthorised repair or modification, incorrect installation, inappropriate environment, accident, act of God or inappropriate application.

If the UPS fails to conform to the above within the warranty period then Rehiko will, at its sole option, repair or replace the UPS. All repaired or replaced parts will remain the property of Rehiko.

As a general policy, Rehiko does not recommend the use of any of its products in life support applications where failure or malfunction of the product can be reasonably expected to cause failure of the life support device or to significantly affect its safety or effectiveness. Rehiko does not recommend the use of any of its products in direct patient care. Rehiko will not knowingly sell its products for use in such applications unless it receives in writing assurances satisfactory to Rehiko that the risks of injury or damage have been minimized, the customer assumes all such risks and the liability of Rehiko is adequately protected under the circumstances



CAUTION: *The UPS system may contain batteries which must be re-charged for a minimum of 24 hours every six months to prevent deep-discharging. Batteries that have been, for whatever reason, deeply-discharged are not covered by the warranty.*

2.7 Extended Warranty

The Standard Warranty may be enhanced by protecting the UPS with an Extended Warranty Agreement (maintenance contract). An Extended Warranty Agreement enhances the standard warranty by providing:

- Regular preventative maintenance inspections
- Guaranteed speed of response to operational problems
- 24 hour telephone support
- Fully comprehensive (excluding batteries) cover

2.8 Additional Service/Maintenance Support

If you are interested in obtaining an extended warranty for your Rehiko PW 1000 (6-10kVA), or require service/maintenance support for any other UPS you may have, please contact Rehiko at the following address:

UK

www.ups.rehiko.co.uk

ukservice.ups@rehiko.com

ukservicesales.ups@rehiko.com

Rehiko web site

Service department – booking service, fault reporting etc.

Extended warranty agreements etc

IRELAND

www.ups.rehiko.ie

ieinfo.ups@rehiko.com

Rehiko web site

Service department, technical queries, hardware sales and extended warranty agreements

3 Installation



CAUTION: Read the safety information contained in Chapter 1 before installing the UPS.

3.1 Unpacking the UPS equipment

The manufacturer has designed robust packaging for your product to help ensure it reaches you in good order; however, accidents and damage may sometimes occur during shipment. You should inspect the UPS carefully upon receipt and if there are signs of damage you must inform the carrier and dealer immediately.



WARNING: Under no circumstances should you connect electrical power to a damaged unit or attempt to start it using its batteries.

Save any recyclable packaging for re-use or dispose of it appropriately and correctly.

1. Remove the UPS from the packing carton.
2. Check the package contents. The standard unit includes:
 - a) User Manual.
 - b) A UPS accessories kit which allows the UPS to be configured for Tower or Rack installation.
3. Before proceeding, check the data plate on the rear of the UPS and verify that the unit's voltage and power ratings comply with the equipment order details. Contact the dealer immediately if this is incorrect.

3.2 Selecting a suitable installation location

Environment considerations:

- Avoid locations with possible high ambient temperature, moisture and humidity:
 - temperature should be between 0°~40°C. The battery temperature must be maintained at 20°C to ensure its lifespan is not reduced
 - humidity should be less than 95% non-condensing
- An adequate cooling air flow must be available if necessary to sustain a suitable ambient temperature
- Ensure no dust or corrosive/explosive gasses are present

Other considerations:

- The UPS is not designed for outdoor use
- The location must be vibration free, clean, dry and free of excessive dust
- If the UPS system is installed as a Tower system, the supporting surface should be non-flammable
- The UPS must not be installed in a corrosive environment or in the vicinity of flammable items
- Local fire protection standards must be respected
- The ventilation grills at the front of the UPS and extractor fans at the rear of the UPS must not be obstructed
- The UPS mains power supply must be readily available
- The UPS and battery must be installed with the clearances illustrated below. If it is to be installed as a Tower system the connected cables must be of an adequate length to allow the UPS to be manoeuvred for maintenance access if necessary, as shown.

3.3 Clearances

3.3.1 Rack-mounted installation

When the UPS is rack-mounted, a minimum space of 200 mm should be available between the rear of the UPS and the back of the cabinet to enable adequate ventilation and provide space for cabling. The cabinet must have a ventilated door and a minimum clearance of 1000 mm must be provided at the front of the cabinet and 800 mm at the rear (preferably 100 mm) for installation and maintenance access, although we recommend that this is increased where possible.



CAUTION: Due to weight distribution considerations, the UPS and Battery enclosures must be kept level while they are inserted into the rack to prevent them from tilting backwards.

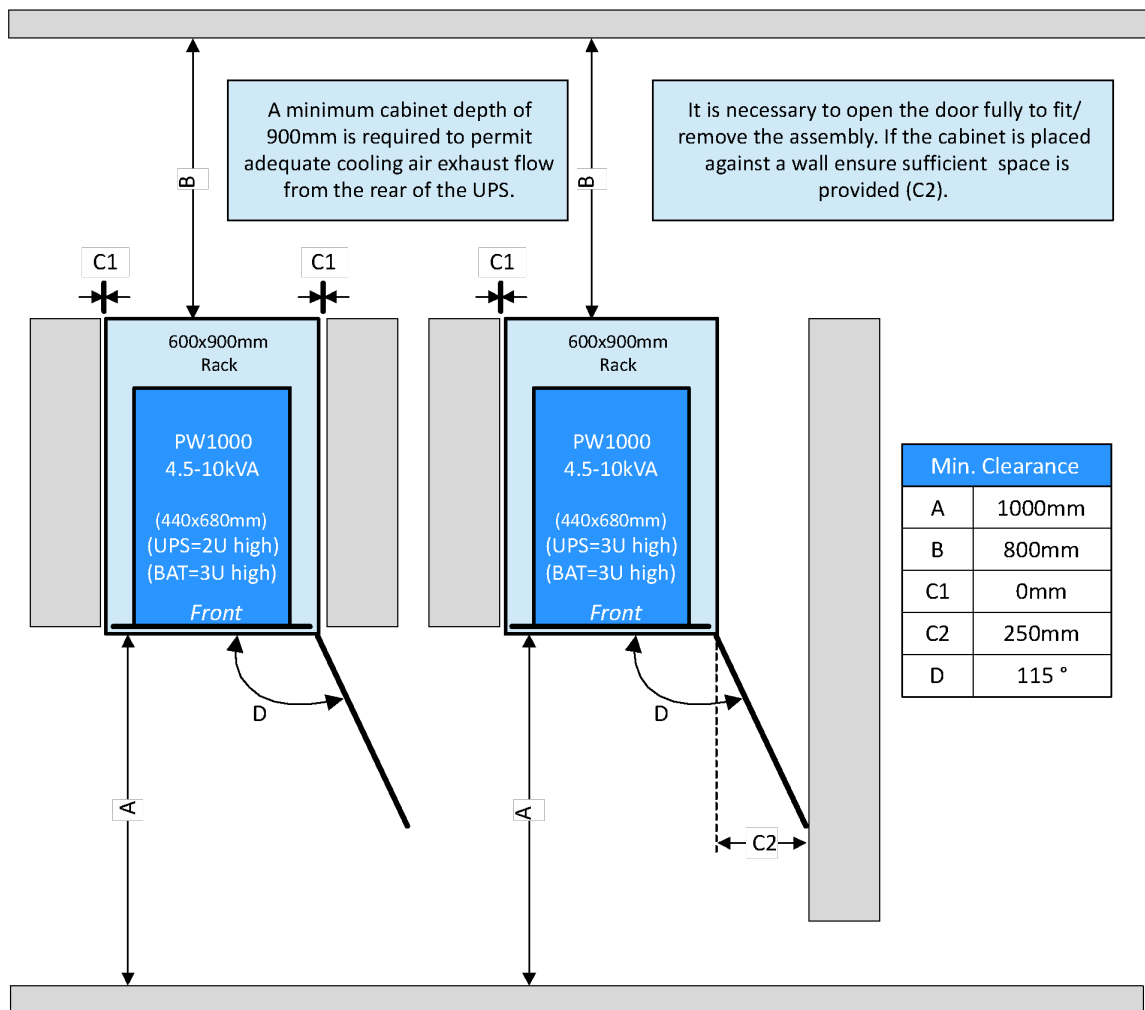

Figure 3.1 Rack mounted installation clearances

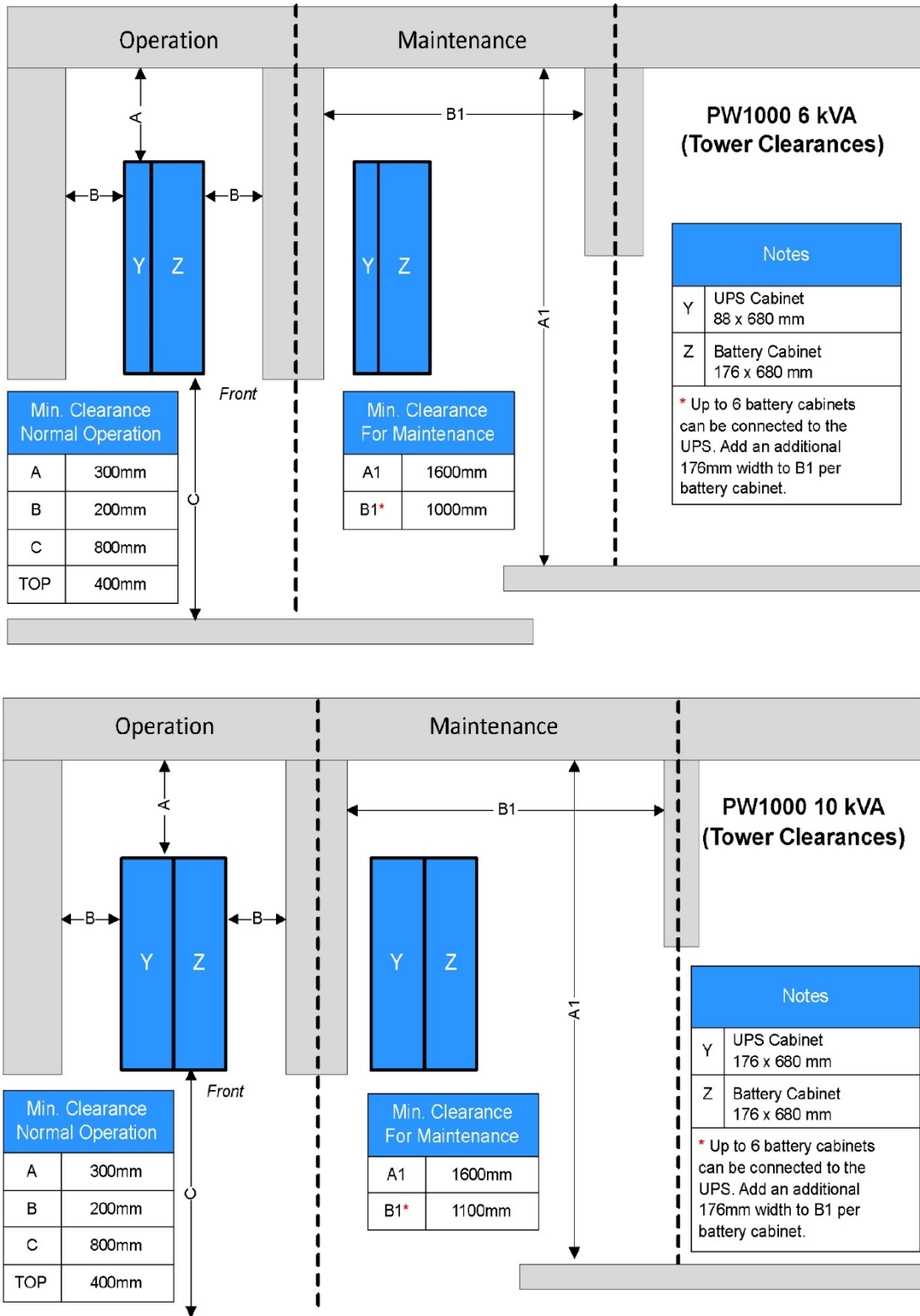

Figure 3.2 Tower installation clearances

3.3.2 Tower installation

Figure 3.2 shows the clearances required when planning a PW1000 tower installation.

The total width of the system hardware can range from 220 mm, for a 6 kVA UPS cabinet with a single battery cabinet, up to a possible 9240 mm for 10kVA unit connected to 6 battery cabinets. Only one battery cabinet is shown in Figure 3.2.

The illustrations on the left of Figure 3.2 show the clearances necessary to provide adequate cooling during normal operation, and those on the right show the clearances required to access the system for maintenance. If the specified 'maintenance' clearance is not readily available, the cables connected to the UPS should be made sufficiently long to allow the UPS to be manoeuvred to a position where an adequate clearance is obtainable.

3.4 Hardware installation

3.4.1 Hardware accessories pack

An accessories pack containing all the hardware required to safely install your UPS as a tower or rack-mounted system is shipped inside the UPS packing carton.

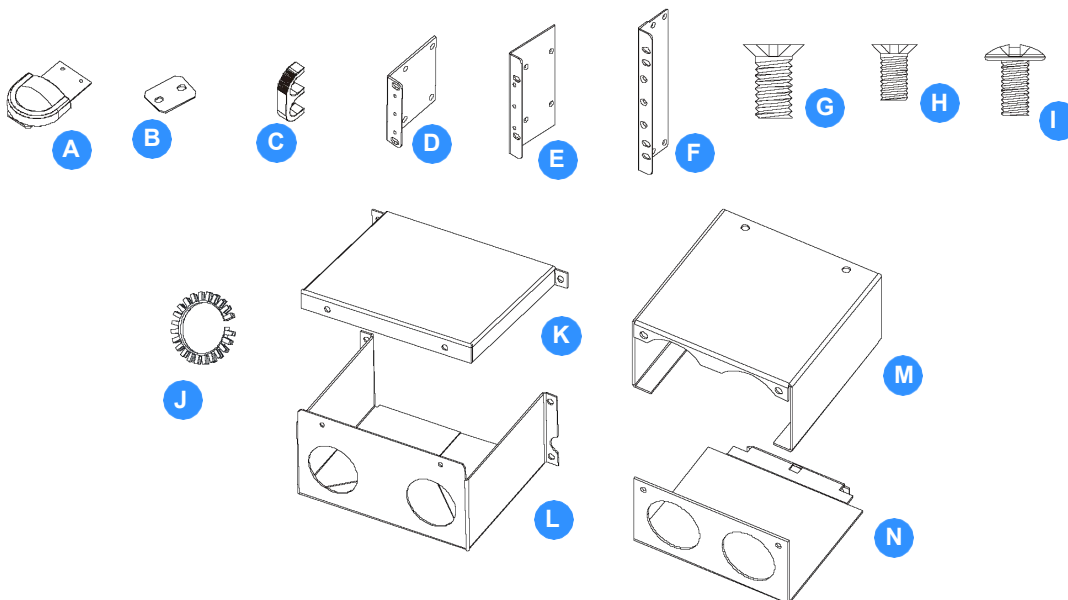

A	4x Tower mounting foot attachment	H	8x M3 Countersunk screw (6.0 mm)
B	2x Tower cabinet linking bar	I	6x/10x M3 Dome headed screw (6.0 mm)
C	2x Rack mounting insertion handle	J	2x Cable gland
D	2x Rack mounting side attachment plate (2U)	K	1x Cable entry box top (10 kVA)
E	2x Rack mounting side attachment plate (3U)	L	1x Cable entry box (10 kVA)
F	2x Rack mounting side attachment plate (4U)	M	1x Cable entry box top (6 kVA)
G	6x M4 Countersunk screw (8.0 mm)	N	1x Cable entry box (6 kVA)

Figure 3.3 Hardware accessories pack

3.4.2 Tower assembly hardware

1. Turn the UPS on its side and, using screws (H) provided, attach four tower feet (A) to the base of the enclosure.
 - a) If the UPS enclosure is being installed as an entirely stand-alone unit, attach all four feet so that they protrude from the base of the unit, as shown in the top part of Figure 3.4.
2. Carefully lift the assembly and stand it on its feet.
3. If necessary, rotate the UPS control panel so that it is correctly orientated. To achieve this, carefully pull the control panel forward to unclip it from its mounting, rotate it to the required orientation, then relocate it and press it back into place.
4. This completes the stand-alone tower UPS hardware configuration.

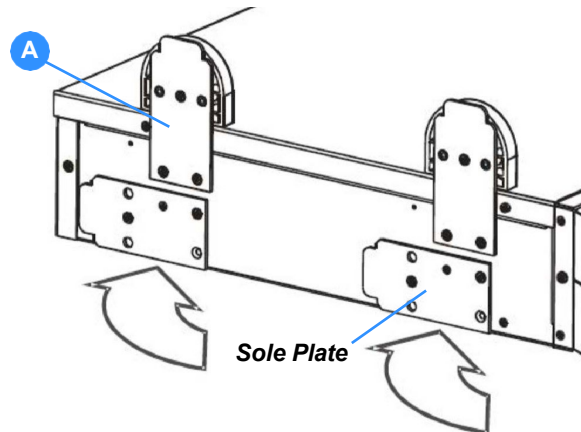

Figure 3.4 Tower assembly

Combined UPS/Battery tower installation

Figure 3.5 shows the method used to join the battery enclosure to the UPS enclosure – the battery enclosure should be installed on the right of the UPS, as shown. Proceed as follows:

1. Attach the feet on the UPS tower enclosure as shown in Figure 3.4.
2. Lay the battery enclosure on its side and attach the feet in the same manner shown for the UPS enclosure – ensuring that the protruding feet are fitted to the battery enclosure outer (right hand) side.
3. With the battery enclosure still on its side (with the feet pointing downwards), carefully place the UPS enclosure on top of the battery cabinet with the front of the units properly aligned.
4. Fit the two link bars (B) between the two cabinets, at the top and bottom, using the supplied dome-headed screws (I). Ensure that the front of the cabinets are correctly aligned before you fully tighten the screws.
5. Carefully stand the assembled tower upright and move it to its intended location.
6. This completes the combined UPS/battery tower mechanical installation.

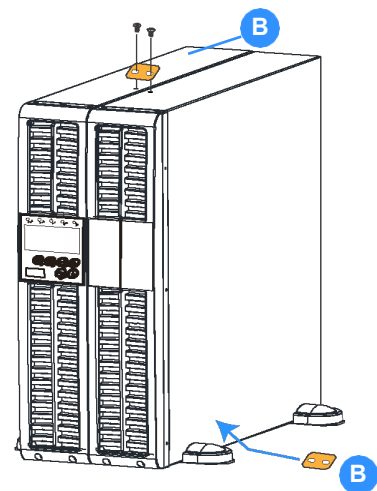

Figure 3.5 Combined tower installation

3.4.3 Rack installation hardware

The UPS and battery enclosures can be installed in a standard 19 inch rack on adjustable mounting rails. Due to their relative weights, it is preferable to mount UPS and battery enclosures near the bottom of the rack with the battery cabinet(s) installed immediately below the UPS. The following procedure applies to mounting both the UPS and battery cabinet(s).



Key Point: Always mount the battery cabinet below the UPS cabinet and as far away from other heat-generating sources as possible.

Rack mounting handles

Mounting handles must be attached to both front side of the cabinet. These are used to help you insert/remove the cabinet and also provide a means of securing the UPS to the rack once it is in position.

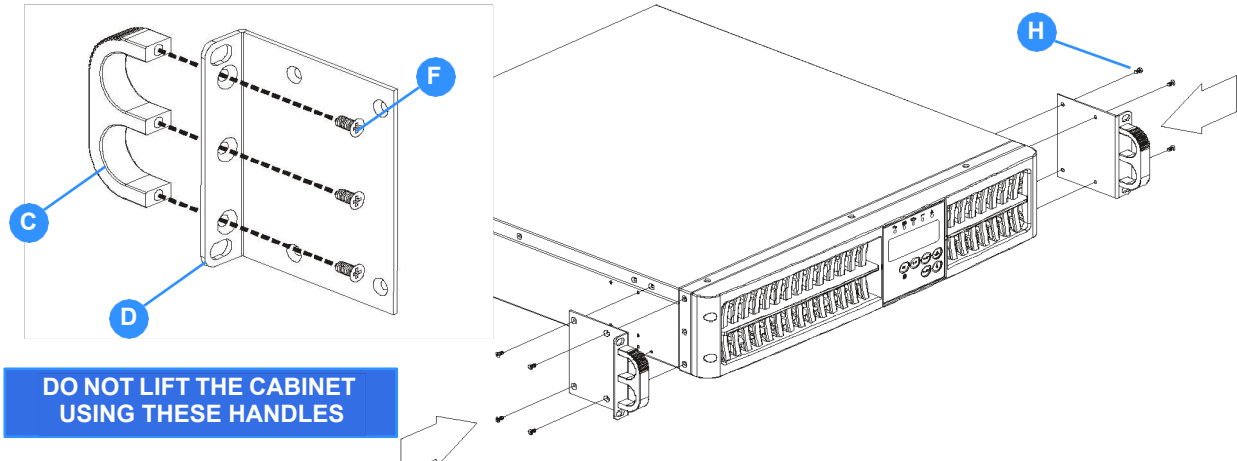

Figure 3.6 Rack mounting handles

1. Attach the rack-mounting handles (B) to the side-plates (C) using three M4x8mm countersunk screws (F).
2. Secure the side-plates to the front of both sides of the UPS, as shown, using four M3x6mm countersunk screws (E).

Note: You will have to remove the M3 screws already fitted to the UPS side panels in order to make way for the new handle attachments.

Adjustable mounting rails

Figure 3.7 illustrates the components contained in the supplied rack-mounting rail kit.

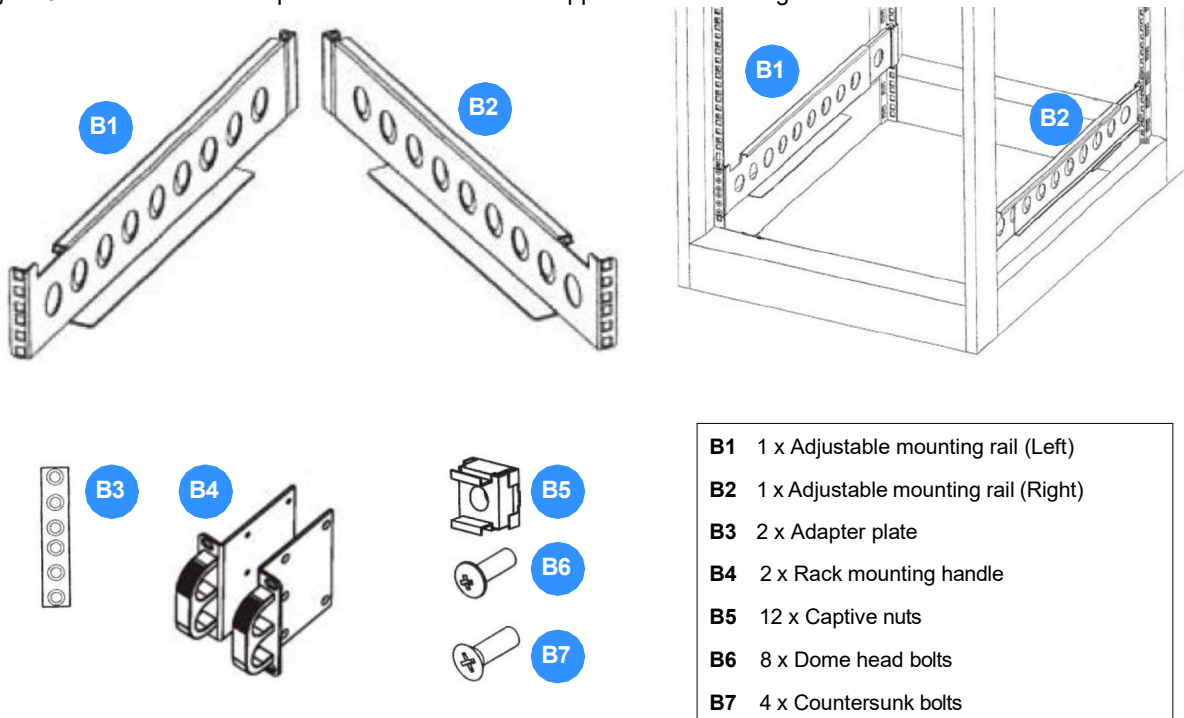

Figure 3.7 UPS Rack mounting kit

The adjustable mounting rail kit contains a pair of mounting rails that are fitted to each side of the cabinet and secured by two screws – front and back. The length of the rails is adjustable between 543 mm and 925 mm, making them compatible with most standard 19 inch rack assemblies of 600 mm to 900 mm depth.

The rails are left and right handed and must be installed with the lip facing the bottom of the rail, as shown in Figure 3.7.

1. Extend the mounting rail and hold in place (see Figure 3.7).
2. Align the two holes in the back of the mounting rail with the holes in the vertical fixing rail on the back of the rack (see Figure 3.8).
3. Identify and mark the two holes in the vertical fixing rail holes to which the mounting rail is to be fixed.
4. Remove the mounting rail and clip captive nuts (B5) to the two vertical fixing rail holes identified above.
5. Secure the rear of the mounting rail to the vertical fixing rail using two dome headed bolts (B6).
6. Extend the mounting rail extended, and identify four points in the vertical fixing rail at the front of the rack that will align with the equipment mounting handles.

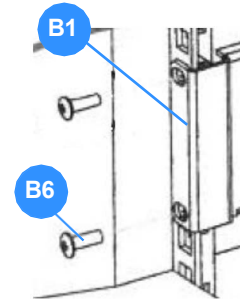

Figure 3.8 Rear fixing

Note: Depending on the depth of the enclosure being installed (2U, 3U, 4U), this may require an adapter plate – see Figure 3.9 for fixing details.

7. Clip four captive nuts to the vertical fixing rail as required.
8. Secure the adjustable mounting rail to the vertical rail using two countersunk screws (B7) and adapter plate (B3) (see Figure 3.9).
9. Repeat the above steps to fit the second adjustable mounting rail.



WARNING: The UPS / Battery enclosure is heavy. When lifting the equipment ensure that adequate manpower is available and any mechanical lifting aids are suitable for the weights involved.

WARNING: When inserting the enclosure into the rack ensure that it is held level. If it is inserted at an angle it could pivot about the back of the mounting rail runners if the front of the enclosure is tilted upwards.

10. When both mounting rails are fitted, carefully insert the Battery and UPS enclosures into the rack so that they rest correctly on the rails. Then secure in place using the four dome head screws (B6) as shown in Figure 3.9.

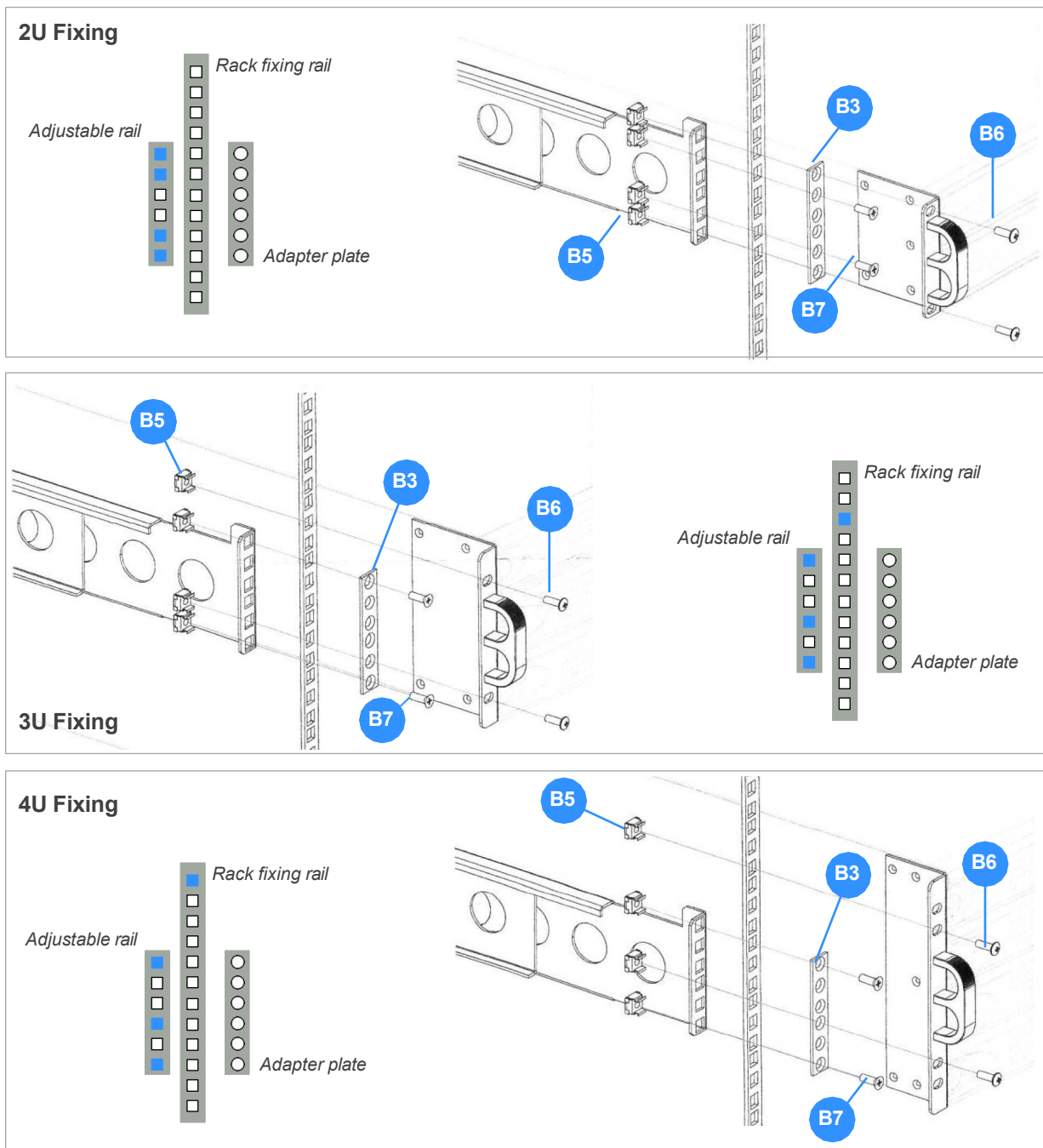

Figure 3.9 Fixing point for captive nuts

3.5 Electrical installation

Carry out the following electrical installation procedure once the UPS and battery cabinets have been mechanically installed at their intended location.

3.5.1 Safety warnings:



WARNING: Please observe the following safety warnings before you start the electrical installation:

- The electrical installation must be performed or supervised by a suitably qualified electrician
- Ensure that the circuit breaker(s) on the back of the UPS and battery enclosures are open (OFF)
- Ensure that the mains supply is isolated/disconnected at the mains distribution panel
- Ensure that the UPS output (load) supply cables are isolated at the load distribution panel, and all load equipment is turned OFF

3.5.2 Cable rating

All cables should be rating in accordance with local regulations suitable for the maximum currents shown in the table below (note that the DC cables are provide ready-connected to the battery cabinet):

MODEL	PW1000 6 kVA	PW1000 10 kVA
Maximum input AC current	36	62
Maximum battery DC current	36	53

3.5.3 Cabling procedure

1. Fit the cable entry box (items J-M in Figure 3.3) to the back of the UPS enclosure. Parts M/N are supplied with the 6 kVA unit and K/L with the 10 kVA.
 - a) Fit the bottom part of the box (L/N) below the terminal block.
 - b) Insert the two flexible cable grommets (J) into the cable entry cut-outs.
2. Connect the UPS input and output cables to the UPS power terminal blocks, as shown below.



Key Point: When connecting the power cables to a Tower system remember to use a sufficient cable length to allow the units to be moved to gain adequate maintenance clearance if needed (see Figure 3.2)

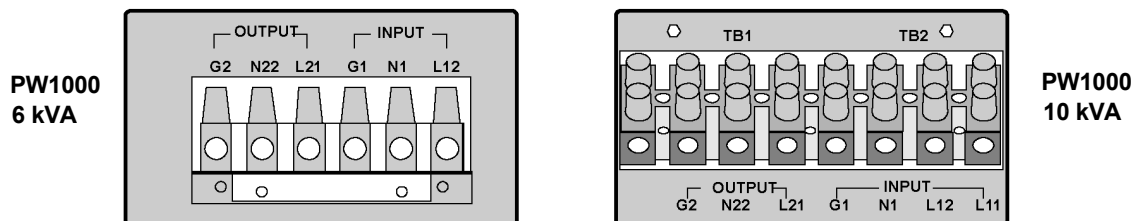

Figure 3.10 Power terminal block connections

- a) Output terminals – L21 Line, N22 Neutral, G2 Ground (PE)
- b) Input terminals – L12 Line, N1 Neutral, G1 Ground (PE), L11 (10 kVA only) Bypass Line if separate bypass supply is used.

Note: Link L11 to L12 on the 10 kVA unit if a separate bypass supply is not being used.

3. When all the connections are made, fit the cable entry box top cover (items K/M in Figure 3.3).
4. If the UPS is installed in an equipment rack, connect a protective earth bonding cable between the rack and the UPS earth screw located adjacent to the battery connector (see Figure 2.8).
5. The optional UPS communications card and other interfaces facilities, such as the emergency power off cables, can be connected at this stage or installed later (see Chapter 7 for details).

Connect the battery cabinet to the UPS



WARNING: Ensure that the circuit breaker on the back of the battery cabinet is open (OFF)

1. On the UPS back panel, remove the screw securing the hinged battery connector cover plate and let the cover plate fall open.
2. Connect the DC cable from the battery cabinet to the external battery connector on the back of the UPS cabinet.
3. With the battery cable inserted, fit the Anderson securing plate over the battery connector plug.
4. (The Anderson plate is shipped with the battery cabinet accessory pack.)
5. Attach the Anderson securing plate to the UPS back panel using the screw you previously removed from the hinged cover plate.
6. Remove the screw from the protective earth terminal on the UPS rear panel.
7. Connect the earth tail from the DC cable to the UPS chassis earth terminal.
8. This completes the electrical installation.

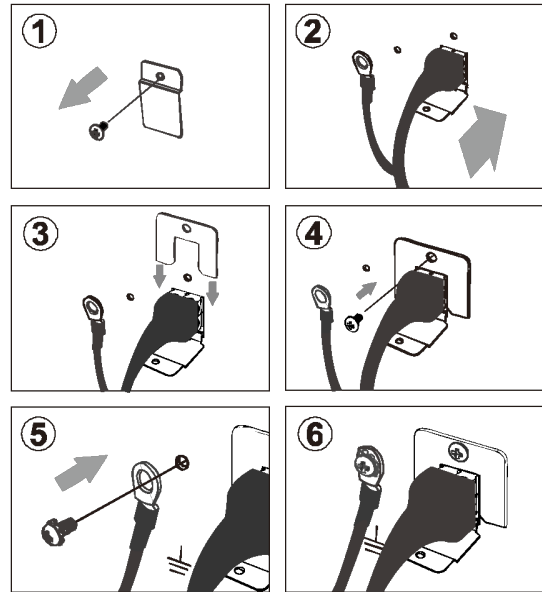

Figure 3.11 Battery cable connection

3.6 External battery charger installation

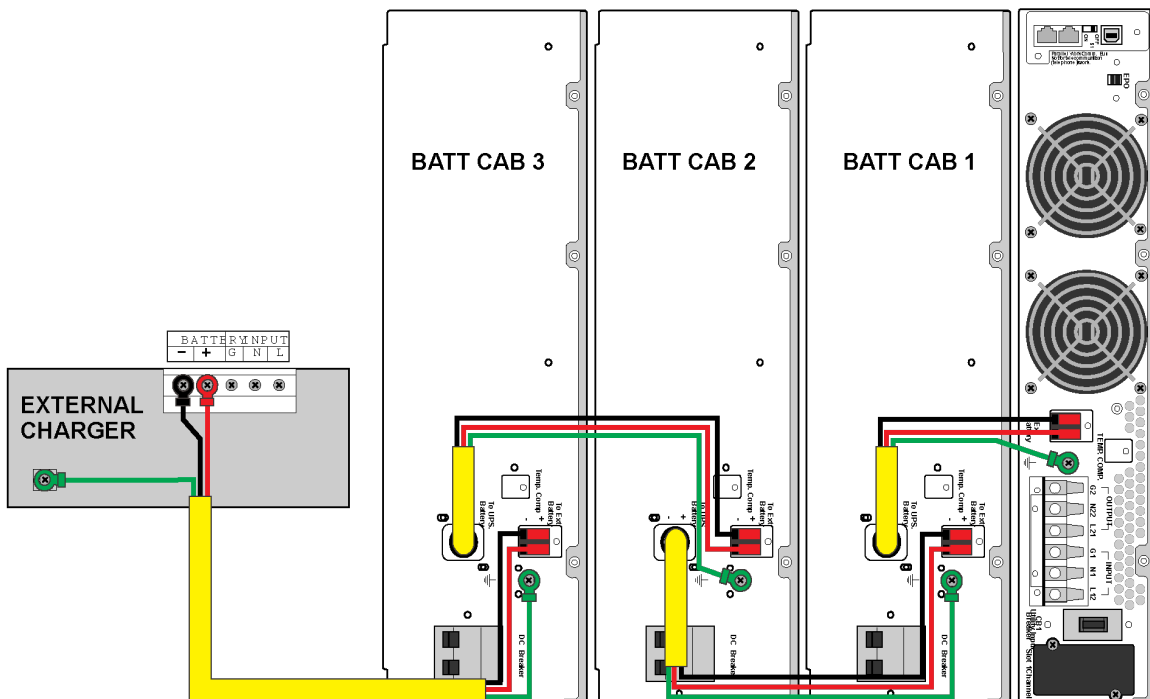

Figure 3.12 External battery charger connection

An external battery charger is only required if three or more battery cabinets are connected to the UPS – the maximum number of battery cabinets that can be connected is six.

Figure 3.12 shows a UPS system comprising three battery cabinets and illustrates how the cabinets are connected together in a daisy-chain fashion.

- The DC output cable from the first battery cabinet is connected to the UPS cabinet's Ext Battery Input socket.
- The DC output cable from the intermediate battery cabinets are connected to the Ext Battery Input socket of the adjacent cabinet.
- Finally, the external charger DC output is connected to the Ext Battery Input socket of the last battery cabinet in the chain (BATT CAB 3).

The correct charger for this system is rated at 273 VDC, 5.0A output and 220-240 VAC input.



WARNING: Only use the external battery charger and DC cable supplied by Rehiko. If you use any other external charger or cable you will invalidate the UPS warranty.

The external battery charger package contains:

- the external charger
- two wall-mounting brackets
- terminal block cover
- pre-terminated DC cable including securing hardware and assorted screws

Four rubber feet are fitted to the bottom of the charger and it can be installed by simply resting it on top of a battery cabinet or wall-mounted using the supplied brackets.

3.6.1 Installation procedure

1. If you intend to wall-mount the charger, attach the two mounting brackets (4) to the base of the unit using the screws provided – ensuring the key-hole plates face away from the charger.
2. Position the charger assembly against the wall and mark out the drilling points through the key-hole slots.
3. Remove the charger and prepare the wall fixings (e.g. rawlplugs, screws).



Key Point: Ensure that the location is close enough to the battery cabinet to allow the DC cable to be connected without straining.

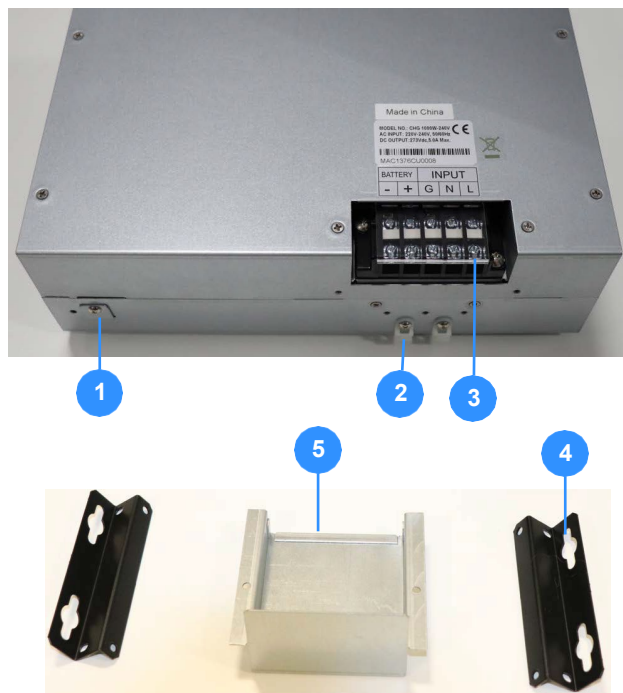

Figure 3.13 External battery charger

Note: It is easier to make the charger's connections before it is finally secured to the wall.

4. Ensure that the battery cabinet DC Breaker is open.
5. Connect the supplied DC cable between the external charger and the battery cabinet as shown in Figure 3.12, using the correct Anderson plate to secure the battery connector in place, as shown in Figure 3.11.
6. The external charger requires a 220/240 VAC mains supply which must be provided by the customer. Before you connect the mains supply ensure that it is safely isolated at source.
7. Connect a mains supply cable between the charger input terminals (G,N,L) and the customer mains supply point.
8. Secure all cables to the two cleats (2) located beneath the terminal block (3) using two cable ties.
9. Fit and secure the terminal block cover (5).
10. If the charger is to be wall-mounted it can now be fitted and secured to the wall fixings.



WARNING: Do not apply mains power to the charger, or close the DC Breaker on the battery cabinet, until the system is commissioned. (See following page.)

3.7 Initial UPS power-up and commissioning

The UPS operating parameters are set to default values by the manufacturer. These basic settings can be changed to suit a particular site or application requirements using the following commissioning procedure.



CAUTION: *The commissioning procedure must be carried out by an electrically-trained engineer.*

1. If the load equipment is connected to the UPS, either disconnect it or ensure that the load power switches are OFF.
2. Connect mains power to the UPS and turn on the UPS following the instructions in paragraph 4.2.1, but do not connect power to the load at this stage.
3. Scroll through the Functions menu, as described in paragraph 4.5.3, and make a note of any operating parameters that require changing.
4. Make any required operating parameter changes as described in paragraph 4.5.4.
5. Turn ON the external battery charger input mains supply, if installed
6. Turn OFF the UPS (paragraph 4.3.1) but leave the mains supply connected for at least four hours to charge the battery.
7. Once the battery is charged, turn on the UPS and carry out a battery test as described in paragraph 4.5.2.
8. If the battery test is successful, the UPS can be brought into operation.



CAUTION: *We recommend that the battery is charged for further 4 hours before you connect any mission-critical load to the UPS. This is to ensure that the battery is charged to a level that enables the UPS to perform to its full specification.*

9. With the UPS running, check all metered parameters to ascertain that the input/battery/output indications are correct.

Congratulations. Your UPS is now fully operational and providing protected power for your load.

4 Operation

4.1 Introduction

This chapter describes the UPS operating and set-up procedures.

The UPS is essentially a 'plug-and-play' unit and does not require a trained operator to turn it off and on.

Set-up procedures are included in this chapter to enable you to re-configure the UPS operating parameters to suit particular local requirements. The factory default settings are satisfactory for the majority of installations, but if you find it necessary to make any adjustments these should be applied before the UPS is put into service.



CAUTION: *If adjustment is necessary it must be carried out by an electrically-trained engineer who is aware of the effects of any changes made to the system.*

UPS Operating procedures

- *How to start the UPS (from utility mains) - see paragraph 4.2.1*
- *How to start the UPS (from battery) - see paragraph 4.2.2*
- *How to monitor the UPS input/output operating conditions - see paragraph 4.2.3*
- *How to turn off the UPS (from ON INVERTER or ECO Mode) - see paragraph 4.3.1*
- *How to turn off the UPS (from ON BATTERY Mode) - see paragraph 4.3.2*
- *How to disable the alarm buzzer operation - see paragraph 4.5.1*
- *How to perform a battery test - see paragraph 4.5.2*

UPS Set-up procedures

- *Functions menu - see paragraph 4.5.3*
- *Operating parameters setting menu - see paragraph 4.5.4*

4.2 UPS start-up procedures

4.2.1 How to start the UPS (from utility mains)

1. We recommend that the individual load power switches are turned OFF before starting the UPS.
2. Close the circuit breakers located on the back of the UPS and battery enclosures.
3. Turn ON the UPS utility mains supply.
 - a) The UPS control system will boot-up and initially turn on all the LEDs and LCD screen symbols. (If the UPS fails to power-up, check that the input breaker is closed on the back of the unit.)
 - b) After a few seconds the UPS fans will start, and the LEDs and LCD symbols will extinguish.
 - c) The UPS is now effectively operating ON BYPASS and will run through a series of self-checks which, if successful, will turn on the battery charger and display the UPS OFF screen (Figure 4.1).

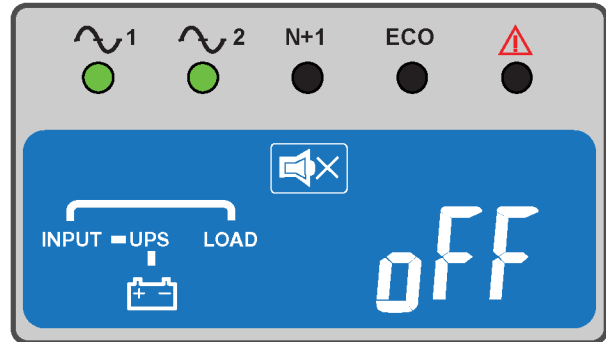

Figure 4.1 UPS OFF

4. The only active LED should be the green input mains LEDs (as shown).
 - a) Press and hold the ON button for approximately 3~4 seconds (until the buzzer beeps twice).
 - a) UPS should turn ON.
 - b) The LCD screen will indicate the bypass supply voltage (Figure 4.2).
 - c) The UPS will carry out further checks, including a battery test (which will take about 4 seconds). The result of the battery test will be shown on the LCD screen if it fails.
 - d) If the UPS passes ALL tests, it will turn ON.
5. The UPS control panel will display its default screen pertaining to its selected operating mode (Figure 4.3).

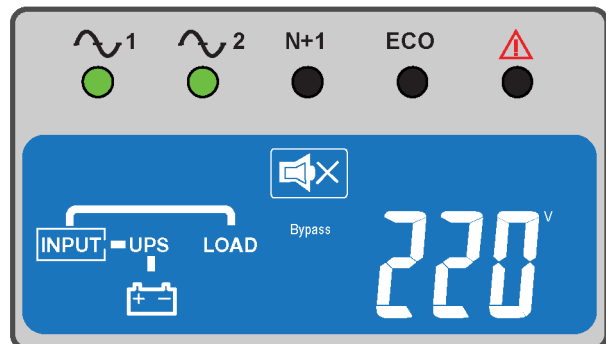

Figure 4.2 UPS BYPASS VOLTAGE

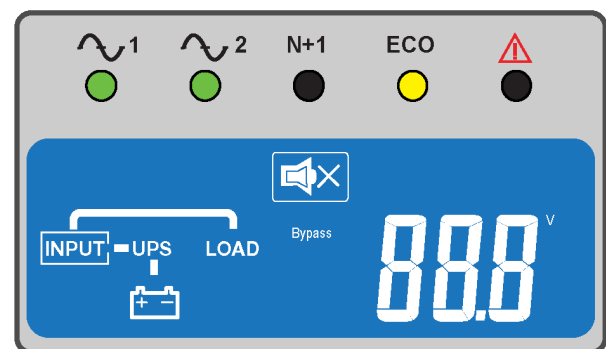
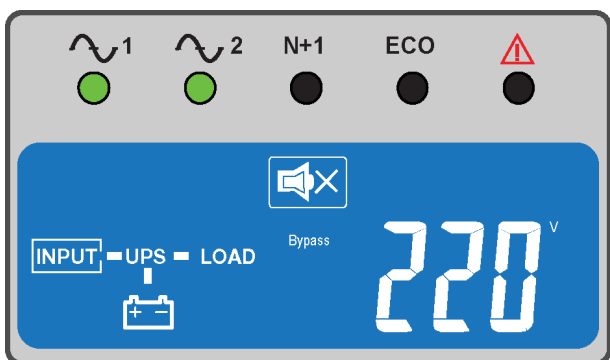

Figure 4.3 UPS Default screen for ON INVERTER operation (left) and ECO MODE operation (right)

6. Press the DOWN button to check for the correct UPS output voltage and frequency on the LCD meter.
7. If this is the first time the UPS is started, we advise you to leave it operating in the current state for 8 hours to fully charge the batteries; then carry out a battery test (paragraph 4.5.2) before you turn on the load equipment.
8. If the battery test is satisfactory, and UPS output voltage is correct, turn ON the individual load power switches (starting with the largest load if possible).
9. Press the DOWN button to check the UPS output current and percentage load on the LCD meter.
10. The UPS is now fully operational.

4.2.2 How to start the UPS (from battery)

If there is no utility mains power available, the UPS can be started directly from battery power.



CAUTION: This requires the battery to be fully charged and should only be attempted if the battery has previously been on charge for at least four hours.

Note: Depending on the load demand the UPS will only function on battery for a short time unless the utility mains supply is connected.

1. We recommend that you turn off the individual load power switches before starting the UPS.
2. Close the circuit breakers located on the back of the UPS and battery enclosures.
3. Press and hold the ON button for approximately 3~4 seconds, until the buzzer beeps twice, then release it.
4. Within a further ten seconds, press and hold the ON button once again (for 3~4 seconds), until the buzzer sounds another two beeps.

Note: If you fail to press the ON button for the second time within the allowed ten seconds the UPS will shut down and you will have to start the procedure again.

- a) The UPS control system will boot-up and initially turn on all the LEDs and LCD symbols for approximately one second.
 - b) After approximately five seconds the UPS fans will start, and the LEDs and LCD symbols will extinguish.
5. This will be followed by the default UPS ON BATTERY screen.
 - a) The LCD mimic diagram should change to indicate the ON BATTERY mode.
 - b) The utility/bypass mains status LED should remain OFF.
 - c) The Utility Abnormal icon should be displayed on the LCD screen.
 - d) The alarm buzzer will beep once per second to inform you that the battery is discharging.
 6. Check the UPS output voltage and frequency on the LCD meter.
 7. Turn ON the individual load power switches (starting with the largest load if possible).
 8. Check the UPS output current and percentage load on the LCD meter.
 9. The UPS is now fully operational in its ON BATTERY mode.

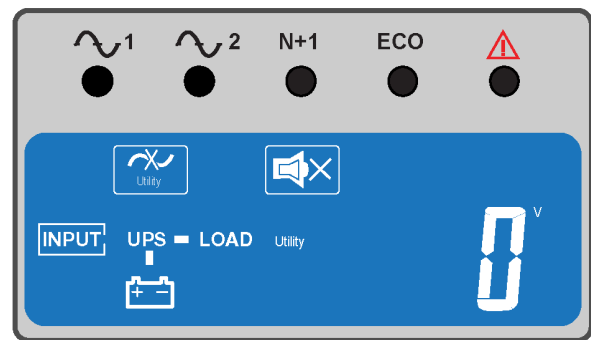

Figure 4.4 UPS ON BATTERY



CAUTION: Restore the UPS utility mains supply as soon as possible, otherwise the UPS will turn OFF and disconnect the load power when the battery discharges to its cut-off voltage.

4.2.3 How the monitor the UPS input/output operating conditions

When the UPS is turned ON, you can use the DOWN and UP buttons to scroll through the measurement display screens. The display sequence is as numbered in the table below and loops around in either direction.

1 Bypass Voltage	5 Inverter Frequency	9 Battery Autonomy
2 Utility Frequency	6 Load %	10 UPS Temperature
3 Bypass Frequency	7 Inverter Current	11 Battery Configuration
4 Inverter Voltage	8 Battery Voltage	12 Utility Voltage

A rectangular box appears around the INPUT, LOAD and BATTERY icons to indicate which is associated with the meter display, as illustrated in the examples below.

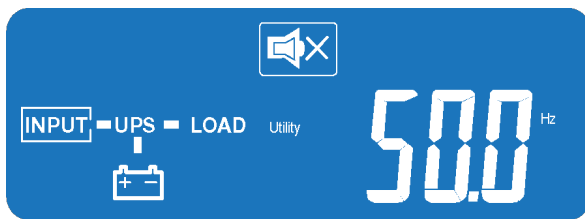

Utility (input) frequency

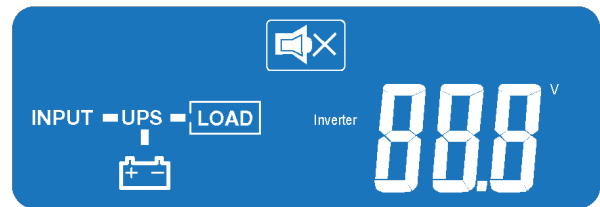

Inverter (output) voltage

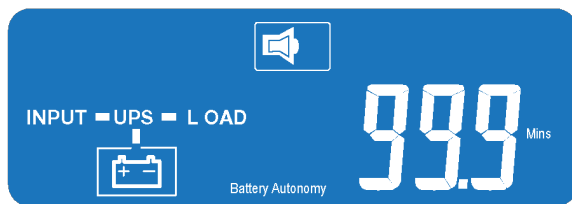

Battery (charge) voltage

Figure 4.5 LCD Meter display (sample screens)

4.3 UPS shut down procedures

4.3.1 How to turn off the UPS (from ON INVERTER or ECO Mode)

Use this procedure to shut down the UPS when it is operating in the ON INVERTER or ECO mode.

1. Press and hold the OFF button for approximately 5 seconds.
 - a) The UPS inverter will turn OFF.
 - b) The utility/bypass mains LEDs should remain ON.
 - c) The LCD mimic should indicate the UPS OFF mode, which shows that the battery is still being charged from the utility mains.
 - d) The cooling fans will remain running.
2. Disconnect (or turn OFF) the Utility input supply (and bypass supply if a separate bypass supply is used).
 - a) All LED indicators and the LCD panel will turn off.
 - b) The cooling fans will stop.
3. The UPS is now totally shut down.

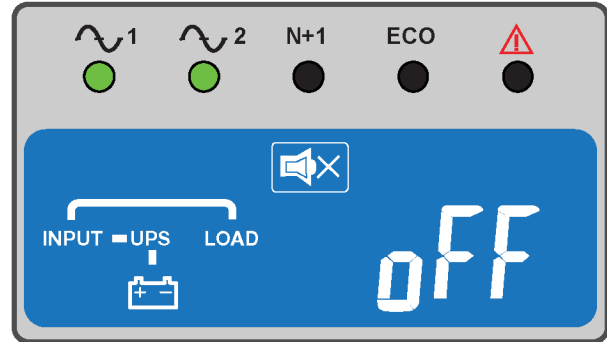

Figure 4.6 UPS OFF

4.3.2 How to turn off the UPS (from ON BATTERY Mode)

Use this procedure to shut down the UPS when it is operating in the ON BATTERY mode.

1. Press and hold the OFF button for approximately 5 seconds.
 - a) The UPS will disconnect the load power.
 - b) All LED indicators and the LCD panel will turn off.
 - c) The cooling fans will remain running for approximately 10 seconds and then shut down.
2. The UPS is now totally shut down.

4.4 Manual load transfer between inverter and bypass

Use this procedure to manually transfer the load between the inverter and bypass.

1. With the UPS operating ON INVERTER, transfer the load to bypass by pressing the OFF button for five seconds.
 - a) The load will transfer to bypass.
 - b) The ECO LED will flash off/on.
 - c) The buzzer will beep at approximately 3 second intervals.
2. To transfer the load from bypass to inverter repeat the process of pressing the ON and UP buttons simultaneously for three seconds.
 - a) The load will transfer to inverter.
 - b) The ECO LED will turn off.
 - c) The buzzer alarm will silence.

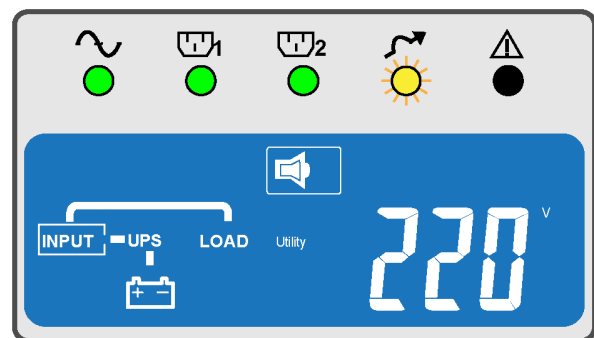

Figure 4.7

4.5 Functions menu

4.5.1 How to disable the alarm buzzer operation

If an alarm condition arises, the buzzer can be silenced by briefly pressing the ON button. However there may be circumstances where you would like to disable the buzzer permanently.

1. With the UPS running, press the FUNCTION button. This will take you immediately to the Buzzer ON/OFF screen.
2. Press the UP button to toggle the Buzzer operational status between OFF and ON, as required. A cross (X) appears next to the buzzer LCD screen icon when it is disabled.



Figure 4.8 Buzzer ON/OFF

3. When the required status is displayed, press the FUNCTION button to return to the default LCD screen.

4.5.2 How to perform a battery test

When a battery test is performed, the UPS operates in ON BATTERY mode for 10 seconds to monitor the battery performance. If the battery doesn't satisfy the test criteria a fault is displayed on the LCD panel.



CAUTION: The battery must be fully charged before you select a battery test. Do not initiate the test until the UPS has been switched on with the battery being charged for at least four (preferably eight) hours.

1. With the UPS turned ON, press the FUNCTION button followed by the DOWN button.
 - a) This will take you to the Battery Test screen, which will indicate that the battery test is OFF.
2. Press the UP button to start the battery test.
3. During the test, the following indications should appear.
 - a) The warning buzzer will beep once per second (if the buzzer is enabled).
 - b) The LCD mimic will change to ON BATTERY mode.
 - c) The Testing flag to the left of the battery icon will flash off/on to indicate that the test is in progress.
 - d) The LCD returns to the Monitor menu during the battery test.
4. When the test is completed, the UPS will switch back to its normal operating mode and the following indications should appear.
 - a) The warning buzzer will stop (if enabled).
 - b) The LCD mimic will change to ON INVERTER mode. [or ECO mode if selected].
 - c) The Testing flag to the left of the battery will turn off.
 - d) The LCD remains indicates the battery autonomy.

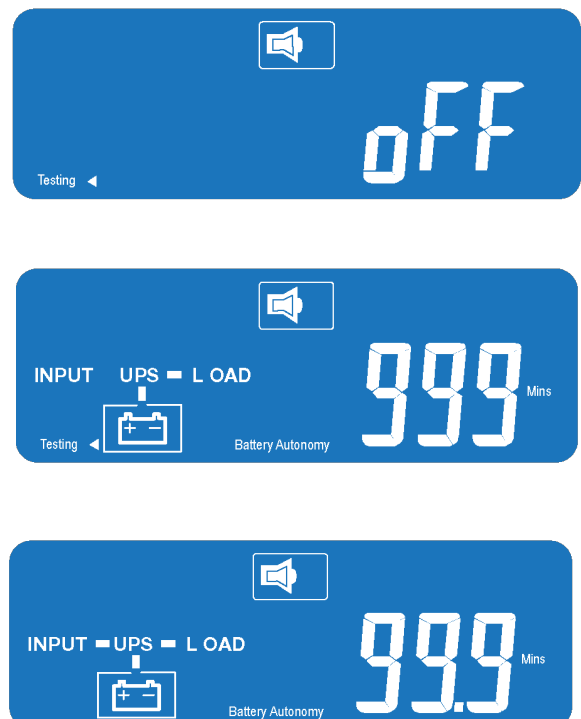

Figure 4.9 Battery Test

5. The UPS is now operating in its normal operating mode and the LCD metering can be selected using the UP and DOWN buttons.

4.5.3 Functions menu

The Functions menu, shown in Figure 4.10, can be accessed when the UPS is operating by pressing the FUNCTION button. The menu allows the operator to enable/disable the buzzer, initiate a battery test and observe (but not change) several UPS preset configuration values.

Once the menu is open you can scroll down through the screens by pressing the DOWN button, as shown.

Buzzer:

Allows the UPS buzzer to be enabled or disabled. This is described in detail in paragraph 4.5.1.

Testing:

Initiates a battery test by switching the UPS to ON BATTERY mode for 10 minutes and monitoring the battery performance. This is described in detail in paragraph 4.5.2.

Bypass Voltage Window:

Displays the bypass voltage window setting. This shows the acceptable bypass voltage range that can be connected to the load when the UPS is operating ON BYPASS and can be either Lo ($\pm 15\%$) or Hi ($\pm 10\%$). This percentage relates to the set inverter operating voltage – for example, if the inverter voltage setting is 230V the bypass sensitivity Lo range is $230V \pm 15\%$, i.e., 195.5-264.5V.

Bypass Frequency Window:

Displays the bypass frequency window to which the inverter will synchronise, which is either 1 [$\pm 1\text{Hz}$] or 3 [$\pm 3\text{Hz}$].

Inverter Voltage:

Displays the selected inverter output voltage setting, which is either [200V], [208V], [220V], [230V] or [240V].

Mode:

Displays the selected UPS operating mode, which be either Std (standard) or Eco.

Inverter Voltage Adjustment:

Displays any applied output voltage offset adjustment, which can be either [-3%], [-2%], [-1%], [0%], [+1%], [+2%] or [+3%].

Note: There are two menu items concerning parallel operation that follow on from the Inverter Voltage Adjust screen; however, the parallel functions are not used in this PW1000 model and can be ignored.



Figure 4.10 Functions menu

4.5.4 Operating parameters setting menu

Figure 4.11 shows the operating parameters that can be accessed and adjusted by the user.



CAUTION: These parameters should be adjusted by an electrically-trained engineer who is aware of the effects on the system of any changes made.

1. Turn OFF the UPS output.
2. To access the settings menu, press the ON and DOWN buttons simultaneously for three seconds, until the buzzer beeps twice.
3. Press the DOWN button repeatedly to scroll down to the parameter you wish to change.
4. To change a parameter, press the UP button to scroll through the option range until the required value is shown.
5. To select the chosen value press the DOWN button.
 - a) This will temporarily store the value and scroll down to the next parameter menu screen.
6. When you reach the final screen (Inverter Voltage Adjust), press the ENTER button.
 - a) Any changes are now saved.
 - b) The LCD return to its default screen
7. Turn OFF the UPS utility mains supply and allow 1 minute for the UPS electronics to fully power down.
8. When the utility mains power is next turned on, the UPS will operate with the new parameter settings applied.

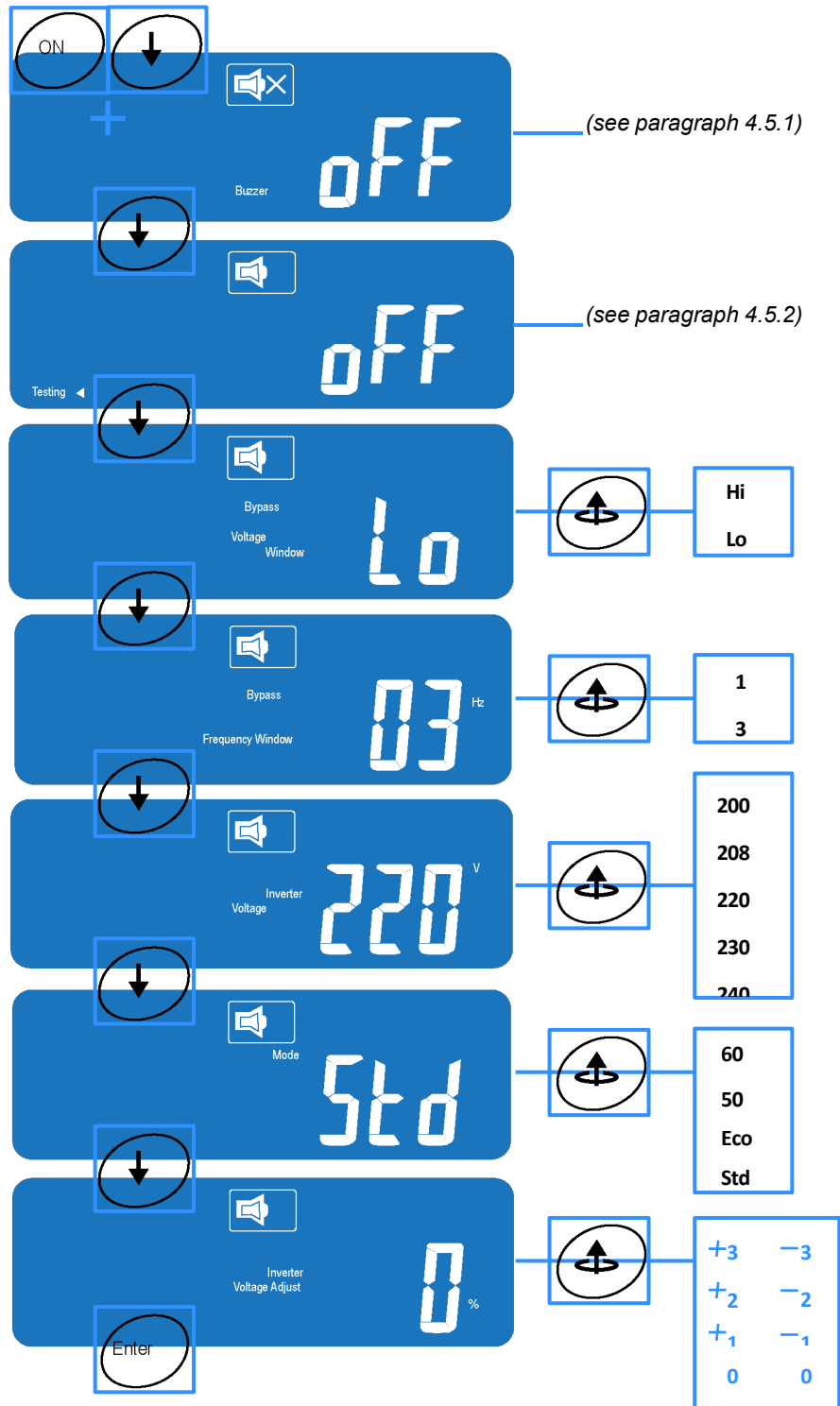

Figure 4.11 Operating parameter setting menu

Note: There are two menu items concerning parallel operation that follow on from the Inverter Voltage Adjust screen; however, the parallel functions are not used in this PW1000 model and can be ignored.

5 Maintenance

5.1 Introduction



WARNING: Do not remove the covers from the UPS case. If you remove a cover you will be exposed to potentially lethal voltages.

The UPS does not contain any user-serviceable parts, so the day-to-day maintenance requirements are minimal other than to ensure that the environment in which the UPS is installed is kept cool and dust free. A clean, controlled operating environment will help maximise the useful working life and reliability of both the UPS and its batteries.

5.2 Scheduled maintenance

The UPS system and batteries should receive regular preventative maintenance from a trained engineer to maximise both the useful working life and system reliability. If the UPS is commissioned by a Rehiko service engineer, the engineer will leave a service record book with the UPS which will be used to log its full service history.

We recommend that the UPS system is maintained every six months by a Rehiko trained engineer or approved service agent, who will complete the following.

Note: Preventative maintenance inspections form an integral part of all Extended Warranty Agreements (maintenance contracts) offered by Rehiko.

5.2.1 Preventative maintenance inspection

During a preventative maintenance inspection a trained Rehiko engineer will check and validate:

- Site environmental conditions
- Integrity of the electrical installation
- Cooling airflow
- Load characteristics
- Integrity of alarm and monitoring systems
- Operation of all installed options
- View all stored event logs and respond if necessary to any repetitive error conditions

5.2.2 Battery maintenance and testing

The batteries should be inspected and tested every six months, depending on the ambient temperature.

The battery test takes approximately five minutes to complete and can be performed only if:

- There are no alarm conditions present.
- The battery is fully charged.
- The UPS input mains supply is present.

The battery test procedure can be carried out from the UPS front panel and performed irrespective of the UPS operating mode (ON-INVERTER or ON-BYPASS/ECO), and whether or not the load is connected.

Battery disposal and recycling



WARNING: Do not attempt to remove or replace the UPS battery yourself. If a battery is faulty ALWAYS seek assistance from Rehko or one of its local service agents.

Batteries contain dangerous substances that can harm the environment if disposed of carelessly. If you have a faulty battery it should be checked and replaced by a trained Rehko engineer who will dispose of any faulty batteries in accordance with any regulations set by local environmental waste disposal organisations.

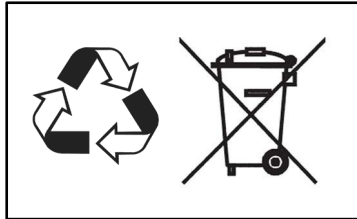

6 Troubleshooting

6.1 Introduction

If the UPS shuts down due to a fault condition caused by an internal malfunction or severe overload, it might need to be reset to bring it back into operation – see paragraph 6.6. Depending on the nature of the fault, the UPS may either shut down entirely and disconnect the load supply, or transfer the load to the internal bypass.

6.2 Fault identification

Unless there is a total UPS failure, the UPS will generally:

- Illuminate the red FAULT LED
- Display a Buzzer Code (error code) number on the LCD screen – the code indication may be steady or flashing depending on other factors
- Sound the audible warning alarm – the audible warning may be cancelled by pressing the ON button briefly
- Illuminate the warning symbols at the top of the LCD screen if applicable

6.2.1 Error codes

Buzzer Codes	
04	Inverter error
05	Weak or faulty battery (after self test)
06	Output short-circuited
07	EPO Operated
11	UPS Over temperature
12	Inverter overload
13	Charger abnormal
14	Fan failure
28	Bypass overload

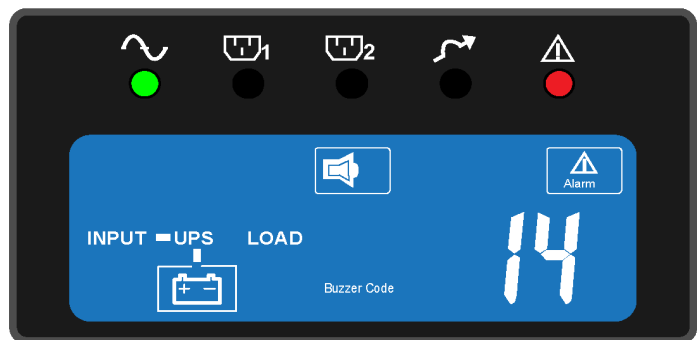









Figure 6.1 LCD Fault Display (Fan failure example)

6.2.2 Audible warning alarm

Audible Alarm (beeps)	
Continuous beep	UPS Faulty, Inverter shut down, keypad error, all functions inhibited
Single beep every two seconds	UPS Faulty, load continued to be supplied via inverter or bypass.
Single beep every second	UPS On-Battery mode, battery discharging
Quick and short successive beeps	Battery low, nearing end of discharge
Two quick and short beeps	Confirm / RS232 port receiving.
One quick and short beep	Service Mode OK

Figure 6.2 Audible warning alarm interpretation

6.2.3 Warning symbols

	Bypass input abnormal: UPS fails to transfer to bypass, bypass abnormal in ECO mode
	Utility input abnormal: The utility mains supply is outside the UPS pre-set operating window
	Wiring fault: Site wiring problem such as reversed Line-Neutral connection
	Alarm buzzer silent The alarm buzzer has been silenced or disabled
	Overload: The UPS output is overloaded
	Service: The UPS is operating in its service mode
	Alarm: An alarm condition is present. This remains active after the audible alarm is reset if the alarm still exists.

6.3 Troubleshooting a fault condition

If the UPS develops a fault during operation (red FAULT illuminated), you should check the error codes listed below for appropriate solutions. Should the problem persist, please contact your local service agent for assistance.

Buzzer Code	Possible Solution
05 / 39	Battery problem: <ol style="list-style-type: none"> When applicable, check that the external battery connections have been made correctly. Measure the battery voltage to ensure it is charged and in good condition. Recharge battery for 8 hours if necessary. Simulate a utility supply outage to establish that UPS is able to provide DC back-up. Seek advice from your local service agent if you find no problem with the above
06	Emergency Power Off (EPO): <ol style="list-style-type: none"> If the external EPO mechanism has been intentionally operated, investigate the reason and rectify any external problems before you restore the UPS operation. If the external EPO mechanism has not been intentionally operated, investigate the external EPO circuit to trace the source of the erroneous EPO command. The external circuit applies a short circuit to the EPO connector on the back of the UPS to effect an EPO shut down. If the external EPO circuit is not faulty, seek advice from your local service agent.
	Overload: <ol style="list-style-type: none"> Disconnect any non critical loads from the UPS output until the overload ceases. Check the condition of the output cables and connectors to determine that they are undamaged and the insulation is sound. Replace the output cables if necessary. Seek advice from your local service agent if you find no problem with the above
11	UPS Over temperature: <ol style="list-style-type: none"> Remove any objects obstructing the ventilation louvres. Check to ensure that the cooling fans are working properly (see also buzzer code 14), and contact your local service support centre to replace the fans if necessary. Seek advice from your local service agent if you find no problem with the above.

Buzzer Code	Possible Solution
	Site wiring/earth fault: <ol style="list-style-type: none"> 1. Check that the utility AC source 'L' & 'N' have been wired correctly. 2. Check that the earth/ neutral voltage does not exceed the limits specified in Chapter 8. 3. Seek advice from your local service agent if you find no problem with the above.
14	Fan error: <ol style="list-style-type: none"> 1. Verify that the ventilating fans are functioning properly. 2. Contact your local service agent for fan replacement. Do not attempt to replace them yourself.
Other	For all other error codes, seek advice from your local service agent

6.4 Troubleshooting an operational problem

Symptom	Possible Solution
UPS fails to provide battery back-up, or the back-up time is shorter than its specified performance.	<ol style="list-style-type: none"> 1. Charge the battery for eight hours. 2. If the back-up time remains unsatisfactory after 8 hours of charging, please contact your local service agent for battery replacement.
UPS operation appears to be normal but there is no output to load.	<ol style="list-style-type: none"> 1. Check that all output power cords are connected correctly. 2. If the problem is with one of the programmable outlets, seek service support who will check the programmable outlets settings and recalibrate them if necessary. 3. If the problem persists, seek advice from your local service agent.
The UPS switches to battery mode then back to on-line mode, when the connected device is turned on. Or, the UPS switches back and forth between battery and on-line mode	<ol style="list-style-type: none"> 1. Check for a faulty UPS input cable or utility supply wall receptacle and replace/repair any faulty item found. 2. If the problem persists, seek advice from your local service agent.
Strange noise and/or odour emitted by UPS	<ol style="list-style-type: none"> 1. Shut down the UPS system immediately. 2. Turn off the utility mains supply. 3. Seek advice from your local service agent.

6.5 UPS Fault handling

ON INVERTER overload

The UPS is equipped with an electronic overload protection feature which switches the load to the bypass line on an inverse capacity/time basis. For example; 105% load (continuous), 106% load (600s), 125% load (30 s) 150% load (160ms), >150% load (instantaneous).

If an overload transfer is caused by starting a load with a high inrush current, it will be short-lived, and once the current being drawn from the bypass falls below <105% the UPS will switch back to ON INVERTER mode automatically.

If the UPS appears to be repeatedly momentarily overloading, it could be due to inrush currents being produced as various multiple loads are started.

ON BATTERY overload

When operating ON BATTERY, the UPS overload characteristics are identical to when operating ON INVERTER. The difference is that, due to the lack of a bypass supply, the UPS is unable to transfer the load to bypass if the load capacity/time characteristic is exceeded, so the UPS will shut down.

ON BYPASS overload

The UPS bypass line is also equipped with electronic overload protection feature. In this case it turns off the bypass (via the static switch) on the following capacity/time basis – 105% load (continuous), 150% load (2s), >200% load (instantaneous).

6.5.1 Output load short circuit when the output supply is via inverter

If output load is short circuited while it is being supplied via the inverter:

1. The inverter will immediately shut down and disconnect the supply to the load.
2. The FAULT led will illuminate and the audible alarm will beep continuously.
3. The UPS will not switch on automatically after the short-circuit condition is eliminated. It has to be re-started manually.

6.5.2 Output short-circuit when the output supply via the bypass line

If the output load is short-circuited while the UPS is operating in ON BYPASS mode:

1. The utility supply fuse/breaker will open to prevent the output load from damage.
2. You must replace the fuse with a fuse of the same rating after the cause of the short-circuit condition has been rectified.

6.5.3 Inverter/internal over-temperature

If the UPS experiences an internal over-temperature when the utility supply is normal it will switch to ON BYPASS mode and switch back to ON INVERTER mode when the over-temperature situation has been eliminated.

If over temperature occurs when the utility supply is abnormal:

1. The audible alarm will beep continuously.
2. The FAULT led will illuminate.
3. The inverter will shut down and disconnect the load supply.

6.5.4 Inverter over-current and output voltage out of tolerance

If the UPS develops a fault and its inverter delivers an over-current and out-of-tolerance voltage:

1. The UPS will switch to ON BYPASS mode as long as the utility supply is normal.
2. The UTILITY led, BYPASS led and FAULT led will illuminate.

If these fault conditions occur when the utility supply is abnormal:

1. The inverter will shut down and disconnect the load supply.
2. The FAULT led will illuminate.

6.6 UPS System reset

The UPS control system may 'lock-up' following a critical abnormal failure condition. If the UPS appears unresponsive to control operations you can reset it using the following procedure:

1. Note and record the error code shown on the LCD screen, and check the information in this chapter to help analyse the cause of the UPS problem. This will be useful if you need to contact the service support centre later.
2. Press and hold the OFF button for at least five seconds.
3. Turn off the utility mains power supply and allow one minute for the UPS control power supply to completely shut down.
4. The UPS control system is now reset and, if the cause of previous fault condition is no longer apparent, you should be able to turn on the UPS as normal.
5. If you are unable to restart the UPS then please seek service support.

7 Options

7.1 Communications options

The UPS can communicate with various external devices and systems, including:

- Hard-wired external Emergency Power Off (EPO) facility.
- A USB port to allow serial communication with monitoring software installed on a remote PC.
- Optional card slot that can be used with:
 - an intelligent CS141 card for local or area network UPS monitoring and control OR
 - a Dry Contact relay card to provide volt-free signalling that can be integrated into an external alarm monitoring or building management system.

All communication ports, including the optional cards, can be active and used simultaneously to monitor the UPS status; however, only one communication interface at a time can control the UPS. This is determined on a priority basis, with the higher priority interface gaining control.

The interface control priorities are as follows:

- EPO input port
- Optional interface card
- Optional USB port

7.1.1 Emergency Power Off (EPO)

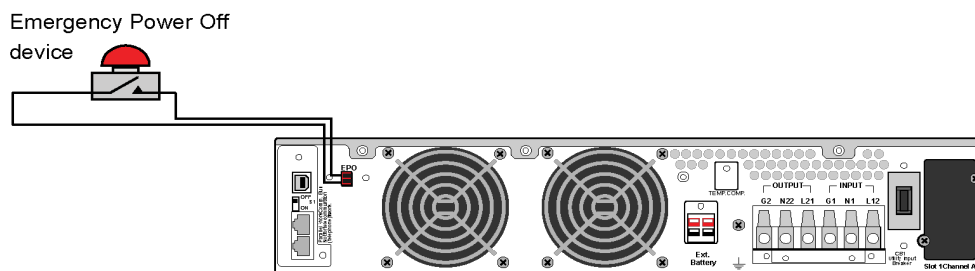

Figure 7.1 EPO Option

The Emergency Power Off (EPO) option allows you to turn off the UPS using an external switch or contact that is hard-wired to the EPO terminal block on the back of the UPS. By default the external circuit should be a 'normally open' contact that will power-off the UPS when the contact is closed; however this can be reversed through software configuration. The EPO connection should be made using a screened, single pair cable (0.5mm²) with a maximum length of 100 metres.

When the EPO circuit is activated the UPS output will turn off, removing power to the load, but the battery charger will remain operational to sustain battery charging. Although an EPO alarm is shown on the LCD display, you can still scroll through the UPS input, battery and output metering.

7.1.2 USB Computer interface

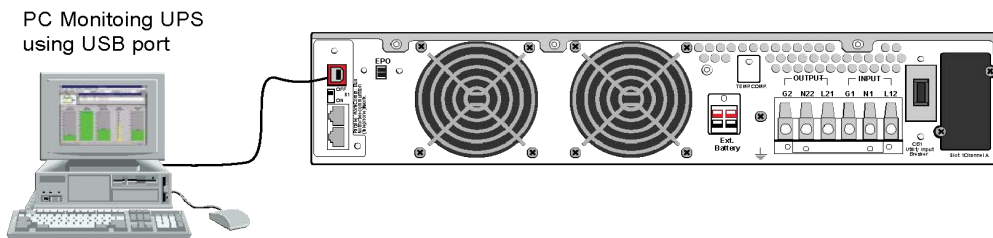

Figure 7.2 USB Interface option

When used in conjunction with suitable software, the USB ports allow the connected PC to continuously monitor the input mains voltage and UPS status, and display appropriate operating data and messages.

The USB connector can be connected to a PC using standard USB cable with a maximum length of 3 metres.

7.1.3 CS141 /SNMP adapters

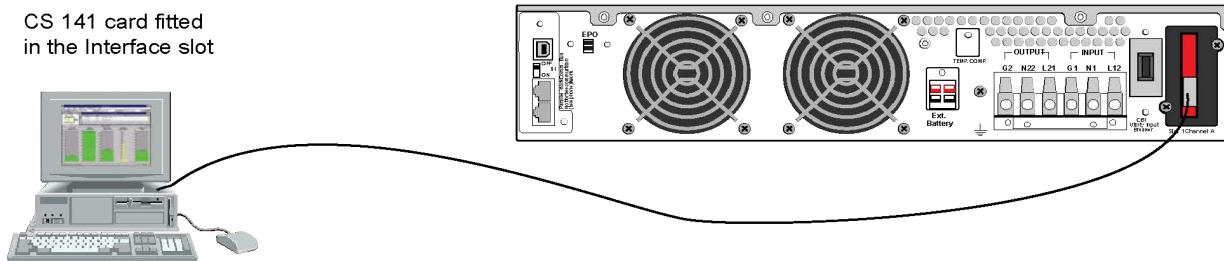

Figure 7.3 CS141/SNMP Adapter card interface option

Simple Network Management Protocol (SNMP) is a world-wide, standardised communication protocol that can be used to monitor any network-connected device via a simple control language and display the results in a browser-based application. The software agent built in to the CS141 adapter card makes the UPS data available in this SNMP format which can then be utilized by a number of UPS management software applications.

The card contains a serial interface, which can be connected directly to a computer's serial port, and an RJ-45 connector which allows it to be connected to a network using a standard CAT-5 cable. The SNMP adapter can be configured via Telnet, http (browser) or serial connection. For normal operation, at least one Ethernet network connection is necessary.

Once installed, the UPS-Management software agent, which is already installed in the card, monitors the UPS operation and outputs its data in SNMP format to the connected network. The card enables automated generation of event/alarm emails, server controlled shut down (with optional licenses) and other tasks, and can also be integrated with BMS software over a local area network (LAN) for SNMP or Modbus information over IP. Rehiko offer monitoring software with SNMP functionality for Novell, OS/2, and Windows that run both on INTEL and on ALPHA, DEC VMS and Apple.

RCCMD

RCCMD (Remote Console Command Module) for 'multi-server shut down' is an independent software module intended for transmitting and receiving 'remote commands'. Using the 'RCCMD send' function, the SNMP adapter can send status messages to connected users or initiate automatic shut down throughout the whole network. Our CS141 SNMP adapters are fully compatible with RCCMD.

7.1.4 Dry Contact card

DCE-C is an UPS management product with 6 relay output contacts for monitoring the status and 3 input contacts as a shutdown UPS command. The volt-free signalling outputs can be integrated into an external alarm monitoring panel or building management system.

All the output connections for R1 to R6 are switched by independent relays and can be configured either N/C or N/O. Details for configuration are provided in the documentation that accompanies the card.

Relay terminals are rated up to 40VDC,800mA.

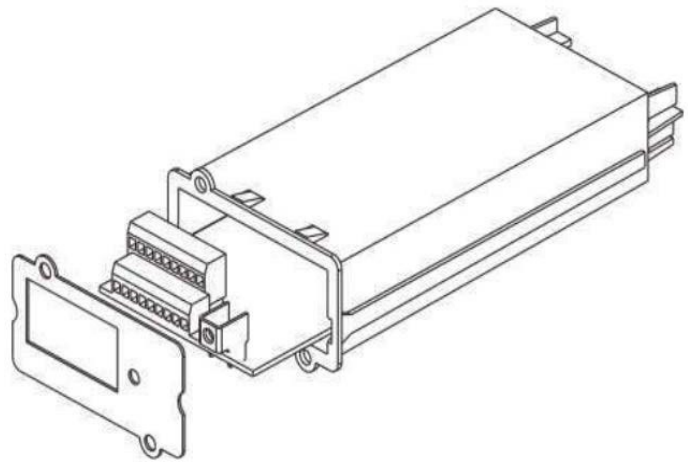

Figure 7.4 Dry Contact card (DCE)

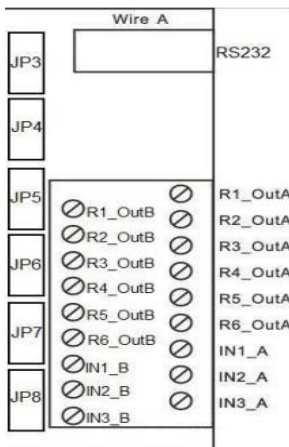

Figure 7.5 Pin outs

In Figure 7.5 the pin outs are displayed and function as table below.

Pin	Function
R1_OutB/R1_OutA	UPS on Bypass Mode
R2_OutB/R2_OutA	Utility Abnormal/Utility Normal
R3_OutB/R3_OutA	Inverter On
R4_OutB/R4_OutA	Battery On
R5_OutB/R5_OutA	Battery Bad or Abnormal
R6_OutB/R6_OutA	UPS Alarm
IN1_A/IN1_B	Remote Shutdown by Utility status
IN2_A/IN2_B	Energy saving shutdown by Utility status and load percentage
IN3_A/IN3_B	Energy saving shutdown by Utility failure time
RS232	Communicate to PC for setting or firmware upgrade

8 Specification

8.1 UPS CABINET

Model Rating		6 kVA	10 kVA
Topology		Double conversion on-line VFI-SS-111	
Form factor		19"-Rack / Tower	
Input:			
Input voltage	VAC	Single phase, 176 - 280 VAC (@100% load) Single phase, 160 - 280 VAC (@75% load) Single phase, 110 - 280 VAC (@50% load)	
Frequency	Hz	45-70 Hz	
Power factor		≥0.99 at full rated linear load	
Input power connection		Hard-wired terminal block	
Output:			
Output capacity	VA	6000	10000
Rated power factor		1.0	
Voltage	VAC	Single phase, selectable at 200/208/220/230/240 VAC	
Voltage regulation	%	±1 (until low battery warning)	
Voltage adjustment	%	±0%, ±1%, ±2%, ±3%	
Waveform		Pure sine wave	
Voltage distortion (THD)	%	≤ 2% (linear load), ≤ 7% (non linear load with CF: 2.5)	
Free running frequency	Hz	50Hz / 60 Hz, ±0.2% when not synchronised to bypass line	
Synchronisation window	Hz	±3 Hz or ±1 Hz (selectable)	
Switching time Inverter-Bypass (typical)	ms	0 ms	
Overload capability (AC Mode) (Tolerance ±1%)	%	<105% Load = continuous operation, from 106%...125% Load = transfer to bypass after 600s -30s. from 126%...150% Load = transfer to bypass after 30s - 160ms >150% Load = transfer to bypass immediately Buzzer continuously alarms	
Overload capability (BATTERY Mode) (Tolerance ±1%)	%	<105% Load = continuous operation, from 106%...125% Load = transfer to bypass after 600s -30s. from 126%...150% Load = transfer to bypass after 30s - 160ms >150% Load = transfer to bypass immediately Buzzer continuously alarms	
Overload capability (BYPASS Mode) (Tolerance ±1%)	%	Up to 105% Load = continuous operation, from 106%...150% Load = shut down after 600~2 Sec. from 150%...200% Load = shut down within 2 Sec. >200% Load = shut down immediately. Buzzer continuously alarms	
Short circuit handling		In normal mode: inverter fuse (internal) In battery mode: inverter fuse (internal) In bypass mode: input/bypass supply breaker	
Over-temperature (AC Mode)		Switch to bypass	

Model Rating		6 kVA	10 kVA
Over-temperature (On Battery Mode)		Immediate UPS shutdown	
Crest factor		3:1	
Heat dissipation @ full linear load (approx)	W	< 450W	<650W
Output power connection		Hard-wired terminal block	
Efficiency:			
Mains operation (Full linear load @230V)	%	93	94
ECO (bypass) mode (Full linear load @230V)	%	98	98
Environmental:			
Temperature (°C)	°C	Operating: 0°C~40°C / Storage: -10°C~50°C The battery temperature must be maintained at 20°C to ensure its lifespan is not reduced)	
Altitude	m	0-1000m without de-rating	
Humidity	%	20%...95%, non-condensing	
Sound level (@ 1 meter)	dBA	<60 dBA	
Battery charger (Batteries installed in separate cabinet):			
Battery charging (from UPS internal charger)		2-mode operation, 2.1A(max), Temp compensation (option) Recharge time to 90% = 4 hrs	
Float charging voltage	VDC	273 VDC ± 1%	
Bulk charging voltage	VDC	273 VDC ± 1%	
Life cycle (typical)		Up to 5 years, at max. 20°C temperature	
Communications			
Standard interfaces		USB, EPO, RS-232	
Optional interface (via expansion slot)		2nd RS-232, USB, CS141 SNMP card, Dry contact relay card	
Supported protocols		J-Bus, Modbus, SEC	
Compatible platforms		Windows, Linux, Mac etc	
Mechanical Data:			
Dimensions (UPS cabinet only) (WxHxD)	mm	440 x 88(2U) x 680	440 x 132(3U) x 680
Weight (UPS cabinet only)	kg	24 kg	45 kg
Dimensions (UPS +1 Battery cabinet) (WxHxD)	mm	440 x 222(5U) x 680	440 x 264(6U) x 680
Weight (UPS +1 Battery cabinet)	kg	52 kg	96 kg
Options:			
Accessories		External bypass Additional battery cabinet(s) Output distribution 19"- rack rails (up to 1 metre)	
Audible Alarms:			
Battery mode		Sounds every 1.5 Seconds	
Battery low		Sounds every 2.0 Seconds	
Overload		Sounds every 3.0 Seconds	
General error		Sounds permanently or every 3 Seconds (error dependent)	
Standards:			
Safety		IEC/EN 62040-1, UL1778	
EMC-Compatibility		EN 62040-2, EN 61000-3-2, EN61000-3-3, FCC Part 15 Class A	
Performance features		EN 62040-3	
Product certification		CE, UKCA	

Model Rating		6 kVA	10 kVA
Protection Class		IP 20	
Manufacturing standards		ISO 9001	

8.2 BATTERY CABINET

Model Rating		6 kVA	10 kVA
Maximum number of battery cabinets		Up to six battery cabinets per UPS module	
Number of battery blocks per cabinet		20 (connected as a single battery string)	
Battery type		12 VDC 7Ah or 8Ah VRLA	
Nominal battery string voltage	VDC	240 VDC	
Dimensions (WxHxD)	mm	440 x 132(3U) x 680	
Weight	kg	11 kg– without batteries 65.4 kg– with batteries fitted (20 off)	
Battery charging (optional external charger)		2-mode operation, 4.1A(max) – Recharge time to 90% = 10 hrs Required if 3 or more battery cabinets are connected	