



# REHLKO **PW** 3000/P1

High-efficiency single-phase uninterruptible power supply

(10 & 20 kVA)

Parallelable up to 80 kVA/kW

## Technical Specification

## Document Control

ISSUE	DATE	REVISION SUMMARY
TS_702_01	18/11/24	Rebranding to KUP International Version
TS_702_02	11/06/26	Rebranding to Rehlko Version, dry port description correction

## Useful Contacts

### UK

[www.ups.rehlko.co.uk](http://www.ups.rehlko.co.uk)

[ukservice.ups@rehlko.com](mailto:ukservice.ups@rehlko.com)

[uktechnicalsupport.ups@rehlko.com](mailto:uktechnicalsupport.ups@rehlko.com)

[uksales.ups@rehlko.com](mailto:uksales.ups@rehlko.com)

[ukservicesales.ups@rehlko.com](mailto:ukservicesales.ups@rehlko.com)

Rehlko Uninterruptible Power web site

Service department – booking service, fault reporting etc.

Technical queries

Hardware sales

Extended warranty agreements etc

### IRELAND

[www.ups.rehlko.ie](http://www.ups.rehlko.ie)

[ieinfo.ups@rehlko.com](mailto:ieinfo.ups@rehlko.com)

Rehlko Uninterruptible Power web site

Service department, technical queries, hardware sales and extended warranty agreements

### SINGAPORE

[www.ups.rehlko.sg](http://www.ups.rehlko.sg)

[salesups.sg@rehlko.com](mailto:salesups.sg@rehlko.com)

[serviceups.sg@rehlko.com](mailto:serviceups.sg@rehlko.com)

Rehlko Uninterruptible Power web site

Hardware sales

Contract customer support, maintenance contracts renewals

All product, product specifications and data are subject to change without notice to improve reliability, function, design or otherwise. Rehlko Uninterruptible Power has taken every precaution to produce an accurate, complete and easy to understand specification document and will assume no responsibility nor liability for direct, indirect or accidental personal or material damage due to any misinterpretation of, or accidental errors, in this manual.

© 2026 Rehlko Uninterruptible Power

This manual may not be copied or reproduced without written permission of Rehlko Uninterruptible Power

## **PW 3000/P1 UPS SYSTEM DESCRIPTION**

Compact and advanced, the PW 3000/P1 is the most energy efficient single-phase UPS in its class. It solves the problem of providing economic-to-run, dependable critical power protection for higher load single phase applications.

Compact, easy to install and operate, with an advanced, intuitive touch screen display, the 10KVA or 20kVA double conversion is also the most energy efficient UPS in its class. For loads up to 80kVA, up to four units can be paralleled.

### **PW 3000/P1 UPS model range**

The PW 3000/P1 range comprises 10kVA or 20kVA single and three phase input and single-phase output, true on-line double conversion UPS models which are contained in identically sized cabinets. Up to forty 12V batteries can be housed within the standard UPS cabinet but, where extended autonomy times are required, additional batteries can be installed in a battery cabinet which can be positioned adjacent to the UPS.

Up to four PW 3000/P1 UPS cabinets can be connected in parallel to increase the UPS system's rated output or introduce a level of module redundancy to further enhance the system availability.

### **Advanced design features**

- True Online double conversion
- Single phase UPS output with either a single or three phase input mains supply
- Supports various input wiring schemes: with either a single input feed connected to both the UPS mains and internal bypass, or a dual input feed using a dedicated single-phase bypass supply
- Paralleling and redundancy capability up to 4 units in parallel increases system capacity and availability
- Energy savings thanks to 96.6% AC-AC efficiency, 99% efficiency in ECO mode
- Unity Power factor
- Small compact footprint
- Communications interface: Network interface SNMP card, dry-contact,
- External maintenance bypass switch connection
- 5" Graphical touch screen display – easy to use, advance interface
- Intelligent charging system able to support additional battery cabinets for extended autonomies
- Wide Input Voltage range (176V – 276V Ph-N)
- Larger internal charger for long runtimes
- Adjustable internal battery voltage (20kVA)
- Digital signal (DSP) technology



Intuitive graphical touchscreen

Internal airflow management, enabling reduced fan size and greater energy efficiency

Large connection terminals and secure gland plates

Internal batteries fitted to minimise footprint, with matching battery cabinets available for extended run times

Full side panel access and wheel mounted for ease of installation and maintenance

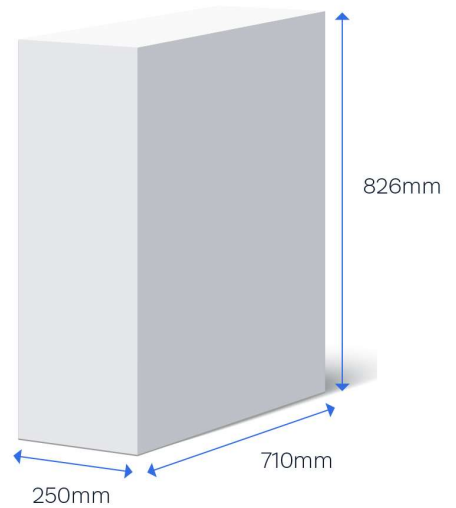

## GENERAL SPECIFICATIONS

### UPS Cabinet

Model Rating		10 kVA	20 kVA
Apparent output power	VA	10000	20000
Real output power PF=1.0	W	10000	20000
Topology		Double conversion on-line VFI-SS-111	
<b>Input:</b>			
Voltage	VAC	Single phase, 1ph + N 220/230/240 Three phase, 3ph + N 380/400/415	
Voltage tolerance	VAC	Single phase, 110 - 300 VAC (@50% load) Single phase, 176 - 276 VAC (@100% load)	
Frequency range	Hz	46 - 54 @50Hz System	56 - 64 @ 60 Hz System
Power factor		>0.99 at full rated linear load	
1Ph Input Current @ 230VAC Ph-N 100% Load (No battery charging)	A	46	92
1Ph Input Current @ 209VAC Ph-N 100% Load (12A battery charging)	A	60	120
3Ph Input Current @ 400VAC Ph-Ph 100% Load (12A battery charging)	A	20	40
Input current THDI		<= 4% @ 100% linear load	
<b>Output</b>			
Voltage	VAC	220/230/240 (Ph - N)	
Voltage regulation	%	±1	
Output Current @ 230VAC	A	43A	86A
Frequency (Synchronized Range)	Hz	46 - 54 @ 50Hz System 56 - 64 @ 60 Hz System	
Frequency (Batt. Mode)	Hz	50 or 60	
Overload capability (AC Mode)	%	100% -110% 60 Min 110% - 125% 10 Min 125% - 150% 1 Min	
Output Short Circuit		3.5x In for 100ms and then 1x In for 300ms.Total 400ms	
Crest factor		3:1	
Harmonic Distortion	mS	0	
Transfer time Inverter - Bypass	mS	0 (in Sync) <4 (Non synchronized)	
Transfer time Line Battery	mS	<10	
<b>Heat Dissipation:</b>			
Airflow		Front to Back	
Heat dissipation with no load	W	165	280
Heat dissipation 1000% Load, 12A charger	W	900	1500

Model Rating		10 kVA	20 kVA
<b>Efficiency</b>			
Mains operation (Full linear load @230V)	%	96.6	
Battery mode (Full linear load)	%	95.5	
<b>Environment:</b>			
Operating Temperature (°C)	°C	0°C~40°C The battery temperature must be maintained at 20°C to ensure its lifespan is not reduced)	
Temperature (°C)	°C	-15°C~60°C (UPS) 0°C~35°C (Battery)	
Altitude	m	1000m without derating	
Humidity	%	<95, non-condensing	
Sound level	dBA	<55 @ 1M	<58 @ 1M
<b>Batteries:</b>			
Quantity (internal 12V battery)		20	32 - 40
Type VRLA		12V	12V
Recharge time to 90%	Hrs	9 Hrs	9 Hrs
<b>Communications</b>			
Standard interfaces		Menu-driven touch Screen display,EPO, USB	
Optional interfaces		SNMP card	
<b>Mechanical Data:</b>			
Dimensions (DxWxH)	mm	710 x 250 x 827	
Weight (No Battery)	kg	43	44
Weight (With Internal Battery)	kg	155	156
Colour		RAL 9005	
<b>Standards:</b>			
Product certification		CE	
Safety		IEC/EN 62040-1-1	
EMC-Compatibility		IEC/EN 62040-2 Category C3	
EMS ESD		IEC/EN 61000-4-2 Level 4	
EMS RS		IEC/EN 61000-4-3 Level 3	
EMS EFT		IEC/EN 61000-4-4 Level 4	
EMS Surge		IEC/EN 61000-4-5 Level 3	
EMS CS		IEC/EN 61000-4-6 Level 4	
Power Frequency Signals		EC/EN 61000-4-8 Level 4	
Low Frequency Signals		EC/EN 61000-2-2	
Leakage Current		EC/EN 62040-1-1	
Protection Class		IP 20	
Manufacturing standards		ISO 9001.2000	

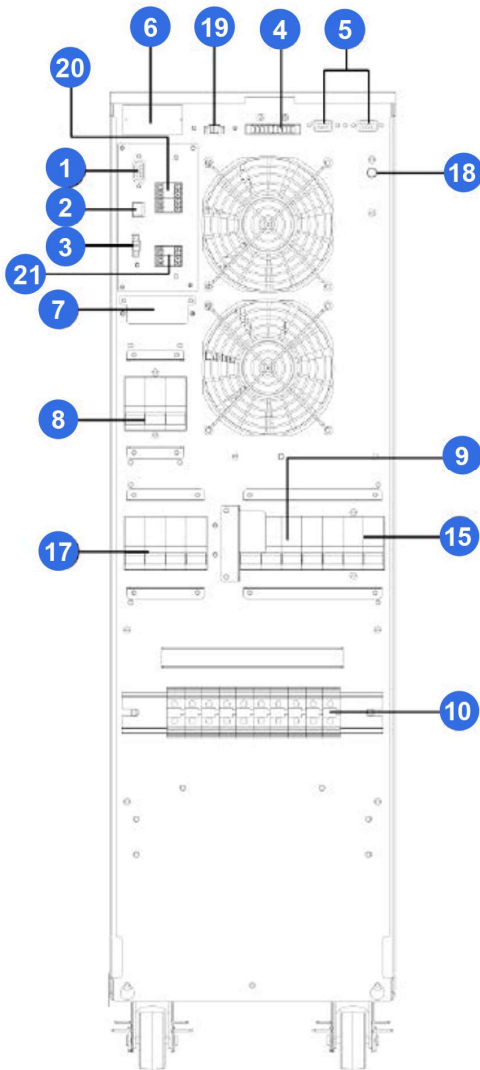

**Diagram 1: Rear Panel**

1. RS-232 port
2. USB communication port
3. Emergency power off connector (EPO connector)
4. Parallel Share current port
5. Parallel port
6. Intelligent slot – SNMP or DRY Port
7. External battery connector / terminal
8. Line input circuit breakers / switch
9. Maintenance bypass switch
10. Input / Output terminals (Refer to diagram 2 for details)
11. Line input terminals

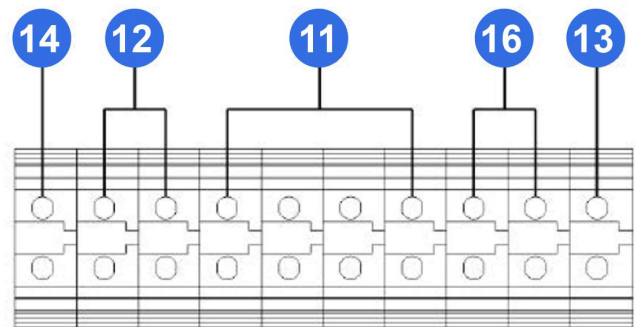

**Diagram 2: Input / Output terminals**

12. Output terminal
13. Input ground terminal
14. Output ground terminal
15. Bypass input circuit breaker / switch
16. Bypass input terminals
17. Output switch
18. Service start
19. External Maintenance Bypass Switch connector (EMBS)
20. Input Dry Port Terminals
21. Output Dry Port Terminals

## 21. INPUT DRY PORT

Provides up to 8 input functions for operating UPS system

Contact	Message	Description
1	Remote on	Remote activation to switch UPS on
2	Remote off	Remote activation to switch UPS off (to bypass)
3	Shutdown - Restore	UPS stops and restarts in 1min
4	Generator Detection	Activates internal generator functions
5	External Output Switch	When external Output switch is Open, the following alarm code is active <b>(45) External Output Switch Open</b> . UPS disconnect from the parallel System
6	BATCB	When battery breaker or switch is Open, the following alarm code is active <b>(46) Battery Switch Open</b> .
7	BYPCB	When bypass input breaker or switch is Open, the following alarm code is active <b>(47) Bypass Switch Open</b> .
8	LINECB	When line input breaker or switch is Open, the following alarm code is active <b>(48) Input Breaker Open</b> .

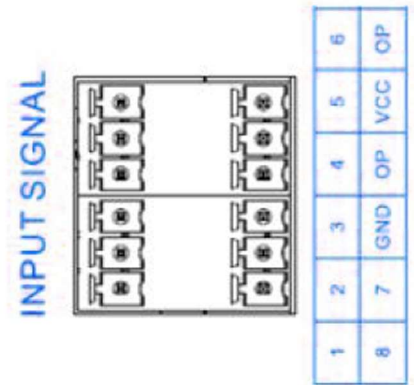

## 22. OUTPUT DRY PORT

Provides up to 6 input functions for monitoring the UPS system, max 1A 24V connection.

Dry ports can be configured NO or NC by service engineer.

Contact	Message	Description
1	Line Failure	The Input voltage or frequency is abnormal.
2	Load on Inverter	UPS is in Inverter mode.
3	Battery Low	Low Battery – Battery near to the end of autonomy.
4	Load on bypass	UPS is in Bypass mode
5	General Alarm	General Alarm (Bypass Mode / Battery Mode / Battery Open / Bypass Loss / UPS Fault UPS Warning / Line Fault
6	Overtemperature	UPS System Temperature is High

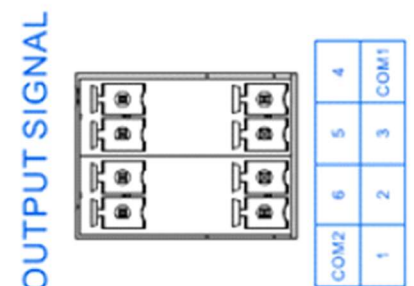

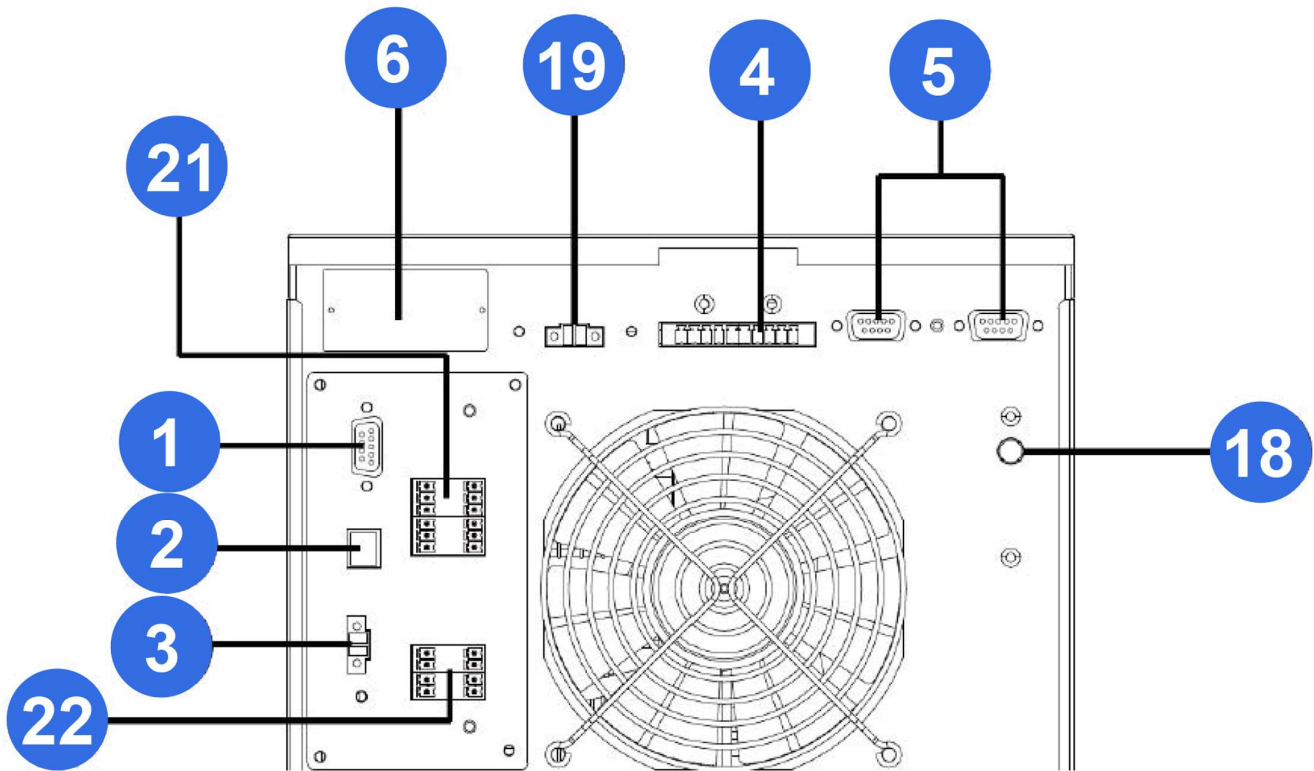

1. **RS232 Port** - Port is used by Maintenance Service engineer to enable updates to internal firmware of the UPS System. Not for Customer Use
2. **USB Port** - Communication port for Customer to connect monitoring Software directly to local PC, provides Alarms and functioning monitoring.
3. **EPO** - EPO port is NC in normal Operation. Breaking this NC loop forces the UPS Inverter to disconnect the output to the load.
4. **Parallel Share Current Port** - Used when multiple UPS systems are connected in Parallel
5. **Parallel Port** - Used when multiple UPS systems are connected in Parallel
6. **SNMP CARD SLOT** - One Slot provided can hold optional SNMP card
18. **SERVICE START** - Allows UPS to be started directly from the battery with no incoming mains supplied
19. **EMBS (External Maintenance Bypass Switch)** - Port is NC in Normal Operation. The EMBS port can be linked to an external Maintenance bypass switch to ensure an interlock is connected to the UPS internal static switch. When installed and the EMBS is closed the Inverter is shutdown and the static transfer switch connects the load directly to the incoming mains supply.

## CS141 / SNMP adapters

### SNMP card / adaptor for network management / remote monitoring

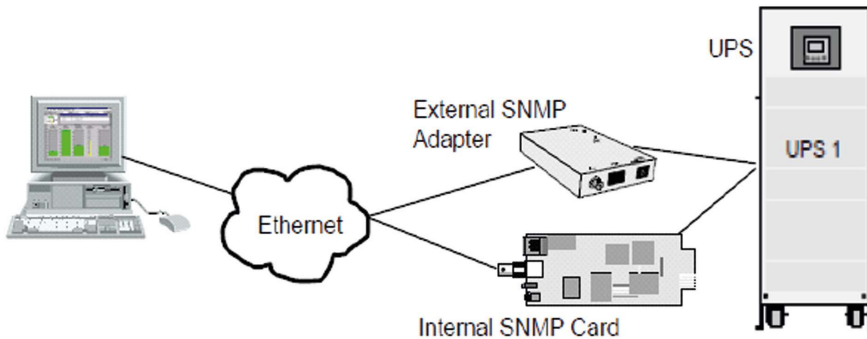

Simple Network Management Protocol (SNMP) is a world-wide, standardised communication protocol that can be used to monitor any network-connected device via a simple control language and display the results in a browser-based application. The software agent built into the CS141 adapter card makes the UPS data available in this SNMP format which can then be utilized by a number of UPS management software applications.

The card contains a serial interface, which can be connected directly to a computer's serial port, and an RJ-45 connector which allows it to be connected to a network using a standard CAT-5 cable. The SNMP adapter can be configured via Telnet, http (browser) or serial connection. For normal operation, at least one Ethernet network connection is necessary.

Once installed, the UPS-Management software agent, which is already installed in the card, monitors the UPS operation and outputs its data in SNMP format to the connected network. The card enables automated generation of event/alarm emails, server controlled shut down (with optional licenses) and other tasks and can also be integrated with BMS software over a local area network (LAN) for SNMP or Modbus information over IP. Rehlko offer monitoring software with SNMP functionality for Novell, OS/2, and Windows that run both on INTEL and on ALPHA, DEC VMS and Apple.

An optional external SNMP adapter can be connected to the UPS via its RS232 port if the UPS card slot is in use (e.g. DCE card fitted) but SNMP facilities are still required.

### **RCCMD**

RCCMD (Remote Console Command Module) for 'multi-server shut down' is an independent software module intended for transmitting and receiving 'remote commands'. Using the 'RCCMD send' function, the SNMP adapter can send status messages to connected users or initiate automatic shutdown throughout the whole network. Our CS141 SNMP adapters are fully compatible with RCCMD.

## INSTALLATION PLANNING

The following *guidelines* should be taken into account when planning a suitable location and environment for the PW 3000/P1 UPS installation.

### Choosing a suitable installation location

#### Environment considerations summary:

- Avoid high ambient temperature, moisture and humidity:
  - temperature should be between 0° to +40°C.
  - the battery temperature must be maintained at +20°C to ensure its lifespan is not reduced
  - humidity should be less than 90% non-condensing
- An adequate cooling air flow must be available if necessary to sustain a suitable temperature
- Ensure no dust or corrosive/explosive gasses are present.

#### Location considerations summary:

- The UPS is not designed for outdoor use
- The installation location must be vibration free, clean, dry and free of excessive dust
- If the UPS system is installed as a Tower system, the supporting surface should be non-flammable
- The UPS must not be installed in a corrosive environment or in the vicinity of flammable items
- Local fire protection standards must be respected
- The ventilation grills at the front of the UPS and extractor fans at the rear of the UPS must not be obstructed at any time
- The UPS power supplies must be readily available
- The UPS equipment must be installed with the clearances illustrated below.

### Clearances

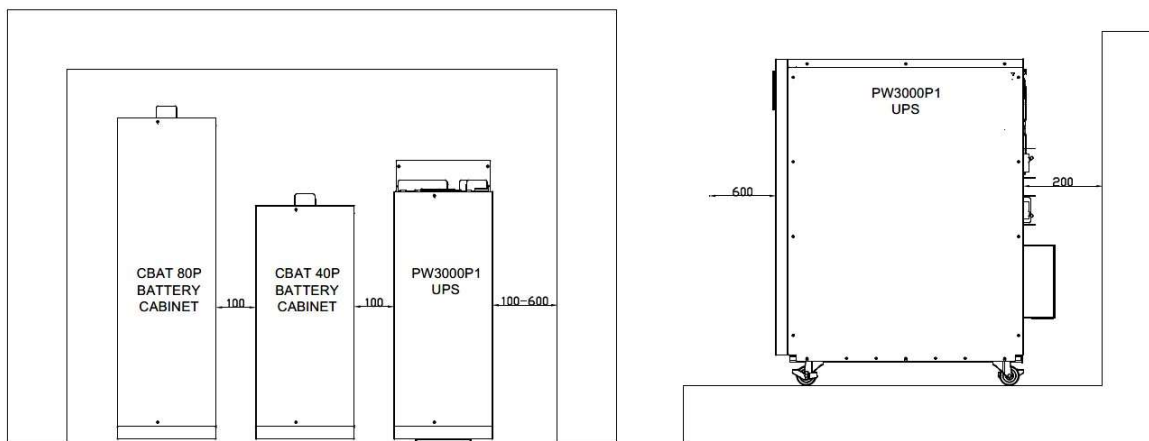

The UPS system is on wheels and can be manoeuvred on solid floor.

The “Positioning Diagram” below details the recommended clearance space around the UPS for correct air flow.

100mm is recommended between cabinets and 200mm behind the UPS cabinet.

Terminals are located on rear of UPS and access should be provided during installation and maintenance.

**NOTE:** For Maintenance purposes 600mm side clearance is required to access batteries and components on both sides. If 600mm side clearance is not available, extra cable should be fitted to allow the UPS to be withdrawn from its position to allow access.

## POWER CABLING

The input cables, output cables and external battery power cables are connected to a terminal block rail located on the back of the UPS cabinet, behind a removable cover. All power cables enter the bottom of the terminal box through cable glands which are installed as required.

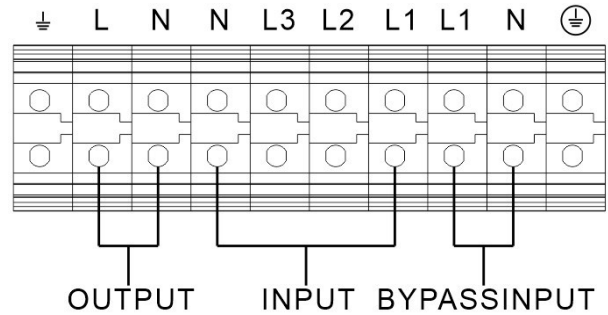

### Input supply configurations

The UPS input supply and bypass supply can be connected to suit various supply configurations and can be described as:

- *Three phase dual input* – Three phase mains input (L1,L2,L3) and separate single phase bypass input (L1)
- *Three phase single input* – Three phase mains input (L1,L2,L3) with the bypass line (M2) linked to (L1)
- *Single phase dual input* – Single phase mains input (L1,L2,L3 linked) and separate single phase bypass line (M2)
- *Single phase single input* – Single phase mains input linked to the bypass input (L1,L2,L3,M2 all linked)

SINGLE FEED - 3 PHASE INPUT

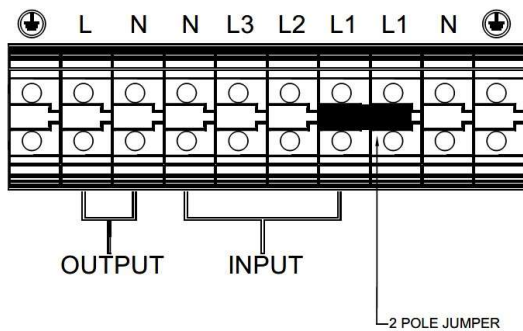

SINGLE FEED - 1 PHASE INPUT

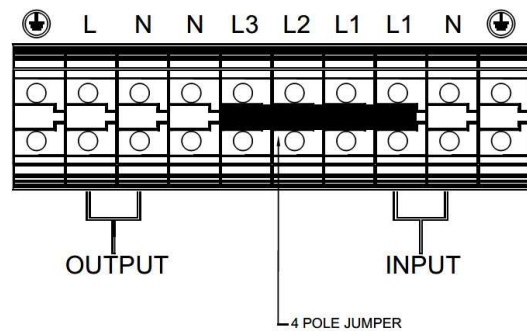

DUAL FEED - 3 PHASE INPUT

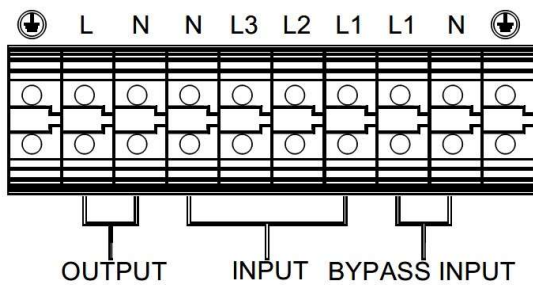

DUAL FEED - 1 PHASE INPUT

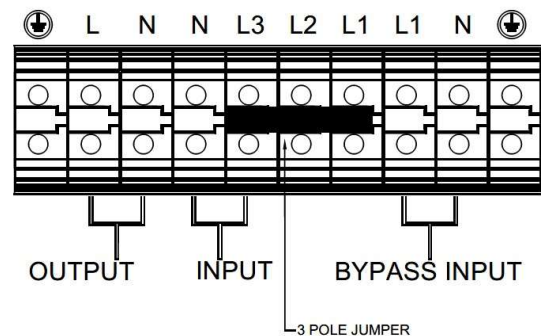

## UPS CABLE AND FUSE SIZING

Model	Wiring Spec (mm <sup>2</sup> ) & Max A per Phase						
	Bypass Input (if used)	Input (1Ph)	Input (3Ph) SINGLE	Input (3Ph) DUAL	Output (Ph)	Neutral	Ground
10 kVA	10mm (60A)	10mm (60A)	10mm (60A)	4mm (20A)	10mm (43A)	10mm	10mm
20 kVA	25mm (120A)	25mm (120A)	25mm (120A)	10mm (40A)	25mm (86A)	25mm	25mm



**Key Point:** The information for Cable and fusing sizing is given for guidance only:

- Fuse and Cable recommendations are to IEC 60950-1:2001.
- All external fuses, isolators and cables must be rated and installed in accordance with the prescribed
- IEC standards or local regulations—e.g. BS76771:
- Maximum current is based on Input Voltage of 230V, 100% load with 12A charger fully operating.

### Power cabling for a parallel system

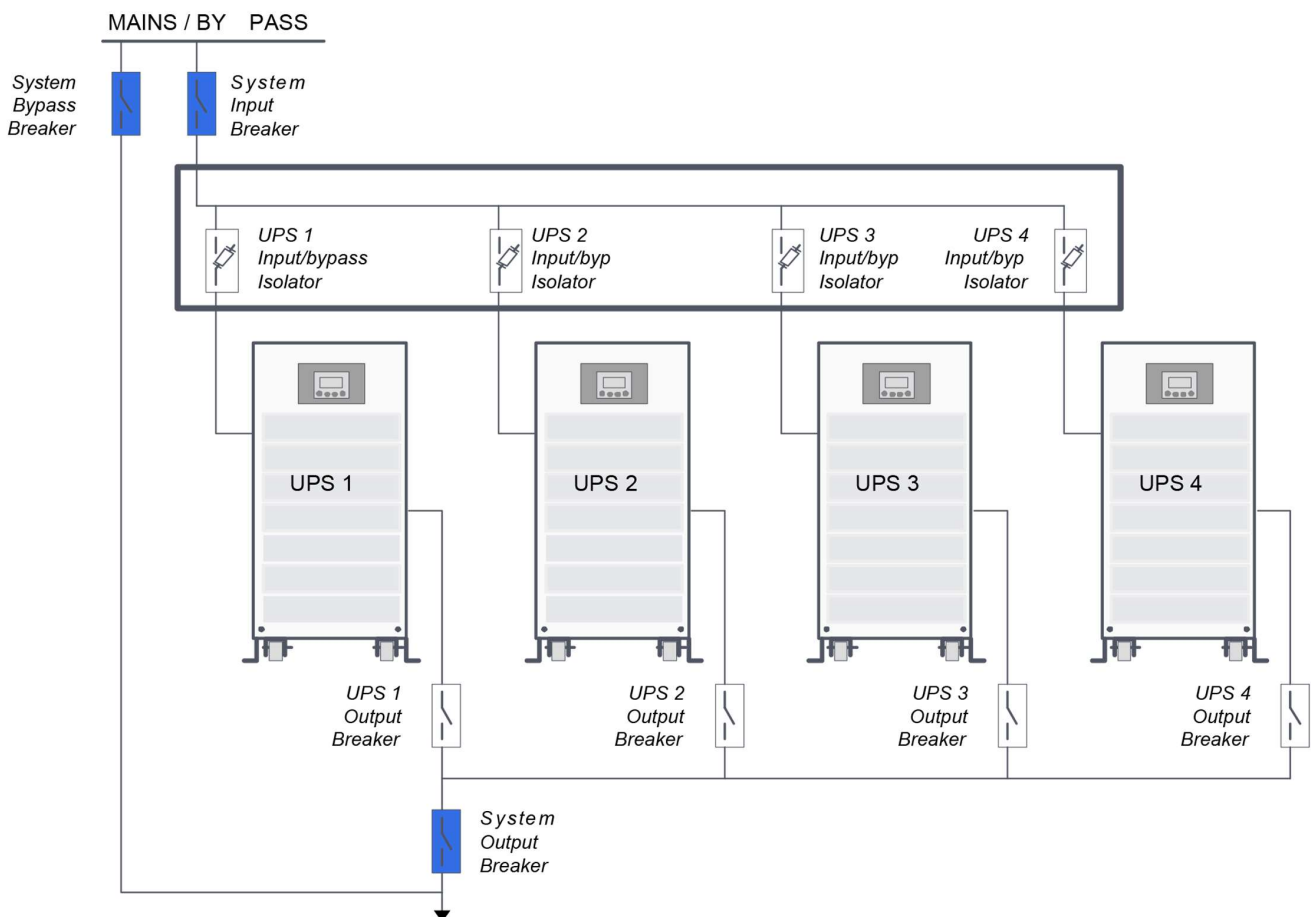

In a parallel UPS system, the length of the input cables from the input distribution board to each cabinet should be as equal as possible, with a maximum difference of 20%. This is necessary to obtain accurate load sharing between the cabinets.

This also applies to the UPS output cables, where each module should be connected to an output circuit breaker located on a switch panel no further than 20 meters from the cabinets.

**Control Cabling for a Parallel system**

