



REHLKO *PW* 6000

Medium to high power three-phase uninterruptible power supply

(60–120 kVA S3)

User Manual

Document Control

ISSUE	DATE	REVISION SUMMARY
TS_825_01	17/10/2023	Rebranding to KUP International Version
TS_825_02	16/09/2024	Torque settings updated chapter 4.4
TS_825_03	21/05/2026	Rebranded to Rehlko, torque settings updated

Useful Contacts

UK

www.ups.rehlko.co.uk

ukservice.ups@rehlko.com

uktechnicalsupport.ups@rehlko.com

uksales.ups@rehlko.com

ukservicesales.ups@rehlko.com

Rehlko web site

Service department – booking service, fault reporting etc.

Technical queries

Hardware sales

Extended warranty agreements etc

IRELAND

www.ups.rehlko.ie

ieinfo.ups@rehlko.com

Rehlko web site

Service department, technical queries, hardware sales and extended warranty agreements

SINGAPORE

www.ups.rehlko.sg

salesups.sg@rehlko.com

serviceups.sg@rehlko.com

Rehlko web site

Hardware sales

Contract customer support, maintenance contracts renewals

All product, product specifications and data are subject to change without notice to improve reliability, function, design or otherwise. Rehlko has taken every precaution to produce an accurate, complete and easy to understand specification document and will assume no responsibility nor liability for direct, indirect or accidental personal or material damage due to any misinterpretation of, or accidental errors, in this manual.

© 2026 Rehlko

This document may not be copied or reproduced without written permission of Rehlko.

Warranty

The REHLKO PW 6000 (60-120 kVA) UPS is supplied with a limited warranty that the UPS and its component parts are free from defects in materials and workmanship for a period of one year from the date of original commissioning, or fifteen months from the date of original delivery, whichever is the sooner. This warranty is the only warranty given and no other warranty, express or implied, is provided.

This warranty is invalidated if the UPS is used without having first been commissioned by a fully trained and authorised person. This warranty does not apply to any losses or damages caused by misuse, abuse, negligence, neglect, unauthorised repair or modification, incorrect installation, inappropriate environment, accident, act of God or inappropriate application.

If the UPS fails to conform to the above within the warranty period then Rehiko will, at its sole option, repair or replace the UPS. All repaired or replaced parts will remain the property of Rehiko.

As a general policy, Rehiko does not recommend the use of any of its products in life support applications where failure or malfunction of the product can be reasonably expected to cause failure of the life support device or to significantly affect its safety or effectiveness. Rehiko does not recommend the use of any of its products in direct patient care. Rehiko will not knowingly sell its products for use in such applications unless it receives in writing assurances satisfactory to Rehiko that the risks of injury or damage have been minimized, the customer assumes all such risks and the liability of Rehiko is adequately protected under the circumstances



CAUTION: *The UPS system may contain batteries which must be re-charged for a minimum of 24 hours every six months to prevent deep-discharging. Batteries that have been, for whatever reason, deeply-discharged are not covered by the warranty.*

Extended Warranty

The Standard Warranty may be enhanced by protecting the UPS with an Extended Warranty Agreement (maintenance contract). An Extended Warranty Agreement enhances the standard warranty by providing:

- Regular preventative maintenance inspections
- Guaranteed speed of response to operational problems
- 24 hour telephone support
- Fully comprehensive (excluding batteries) cover

Contact the Service Support Hotline on 0800 731 3269 (24Hr.) for further details

Additional Service/Maintenance Support

In addition to providing support for the REHLKO PW 6000 (60-120 kVA), Rehiko can provide maintenance and support of a wide range of different UPS products.

If you are interested in obtaining an extended warranty for your REHLKO PW 6000 (60-120 kVA), or require service/maintenance support for any other UPS you may have, please contact Rehiko at the following address.

UK

www.ups.rehiko.co.uk

ukservice.ups@rehiko.com

uktechnicalsupport.ups@rehiko.com

uksales.ups@rehiko.com

ukservicesales.ups@rehiko.com

Rehiko web site

Service department – booking service, fault reporting etc.

Technical queries

Hardware sales

Extended warranty agreements etc

IRELAND

www.ups.rehiko.ie

ieinfo.ups@rehiko.com

Rehiko web site

Service department, technical queries, hardware sales and extended warranty agreements

SINGAPORE

www.ups.rehiko.sg

salesups.sg@rehiko.com

serviceups.sg@rehiko.com

Rehiko web site

Hardware sales

Contract customer support, maintenance contracts renewals

Contents

1. Safety	1
1.1 Description of symbols used in this manual	1
1.2 User precautions	1
1.3 Declaration of Safety conformity, UKCA and CE marking	2
2. General Description	3
2.1 Introduction	3
2.1.1 Reliability and quality standards	3
2.1.2 Key features	3
2.2 REHLKO PW 6000 (60-120 kVA) model range	4
2.3 UPS module functional description	5
2.3.1 UPS module block diagram	5
2.3.2 UPS internal operating modes	7
2.3.3 System operating modes	9
2.4 Multi-module parallel UPS system	9
2.4.1 Parallel system concept	9
2.4.2 Parallel UPS system operation	10
2.4.3 Common battery	11
2.5 REHLKO PW 6000 (60-120 kVA) User Controls	11
2.5.1 Power isolators	11
2.5.2 UPS Control panel	12
2.6 LCD Control Panel	12
2.6.1 Module mimic LED indicators	12
2.6.2 Operator buttons	13
2.6.3 Power Management Display (PMD)	13
2.7 UPS Communication interface	16
3. Installation Planning	17
3.1 Introduction	17
3.2 Environmental and mechanical planning	17
3.2.1 Environmental considerations	17
3.2.2 Installation clearances	18
3.3 Electrical and cabling planning	20
3.3.1 General requirements	20
3.3.2 Cable and fuse sizing	21
3.3.3 Power cabling in a parallel system	24
3.3.4 External maintenance bypass switch	25
4. Installation Procedure	26
4.1 Introduction	26
4.2 Taking receipt of the UPS	26
4.2.1 Reporting transportation damage	26
4.2.2 Local transportation	27
4.2.3 Storage	27
4.3 Unpacking	27
4.4 UPS Cabling procedure	30

4.4.1 Power cable terminations	30
4.4.2 Safety notes	31
4.4.3 Connecting the UPS Input mains cables	32
4.4.4 Connecting the UPS output cables	32
4.4.5 Connecting the battery	33
4.5 Remote monitoring and control facilities	33
4.5.1 Module communications interface	33
5. Operating Instructions	35
5.1 Introduction	35
5.1.1 Operating procedure summary	35
5.1.2 General warnings	36
5.2 How to start the UPS system from a fully powered-down condition	36
5.3 How to start the UPS system from the maintenance bypass	38
5.4 How to transfer the load to the maintenance bypass	38
5.5 How to shut down the complete UPS system	40
5.6 Operating in ECO ('on bypass') mode	40
5.6.1 How to Turn ON the UPS system and operate in 'on bypass' (ECO) mode	40
5.6.2 How to Turn OFF the UPS system when operating in 'on bypass' (ECO) mode	40
5.6.3 How to transfer between ECO ('on bypass') and 'on inverter' mode	40
5.7 Individual module stop/start procedure (redundant parallel system)	41
6. Maintenance	43
6.1 Introduction	43
6.2 User responsibilities	43
6.3 Battery testing	43
7. Troubleshooting	44
7.1 Alarms	44
7.2 LCD Control panel	44
7.3 Troubleshooting table	45
7.4 Contacting service	45
8. Options	46
8.1 Introduction	46
8.2 Customer control inputs (X1)	47
8.2.1 Remote shutdown	47
8.2.2 Generator ON facilities	48
8.3 Customer outputs (+USB)	48
8.4 Serial RS232 Computer interface – USB & JD1 (Smart Port)	49
8.5 RS485 Interface for multidrop	49
8.6 SNMP Card slots	50
8.7 UPS Monitoring and automated control software	50
8.7.1 The importance of UPS management	50
9 Specification	51
9.1 GENERAL SPECIFICATIONS	51

1. Safety

1.1 Description of symbols used in this manual



WARNING: The warning symbol is used where there is danger of an electrical shock, equipment damage or personal injury.



CAUTION: The caution symbol is used to highlight important information to avoid possible equipment malfunction or damage.

1.2 User precautions



WARNING: Keep this manual with the UPS for future reference.



WARNING: The UPS and peripheral equipment must be installed by suitably qualified and trained personnel who are aware of the potential shock hazards.



WARNING: Do not attempt to install this UPS system until you have read and understood ALL the safety instructions and hazard warnings contained in this manual.



WARNING: High leakage current!

Ensure that the UPS has been correctly earthed before you connect the mains power supply.



WARNING: Do not apply electrical power (AC or DC) to the UPS system before it has been commissioned by a Rehiko approved engineer.



WARNING: Do not attempt to operate the UPS system until it has been fully commissioned and handed over. The commissioning engineer will provide operator training as part of the commissioning procedure.



WARNING: Do not open or remove the UPS covers. You run a risk of exposure to potentially lethal voltages if you open or remove the UPS covers! All servicing must be performed by a Rehiko approved engineer.



WARNING: When operating this equipment always follow the procedures contained in this User Manual. Rehiko will assume no responsibility or liability for accidents or injuries due to incorrect operation or manipulation of the UPS or peripheral equipment.



CAUTION: The PW6000 is a Class A UPS product (according to EN 62040-3). In a domestic environment the UPS may cause radio interference. In such an environment the user may be required to undertake additional measures.

1.3 Declaration of Safety conformity and CE marking

The REHLKO PW 6000 (60-120 kVA) UPS system is designed and manufactured in accordance with Quality Management Systems standard ISO 9001 / EN 29001. The CE marking indicates conformity to the EEC Directive by the application of the following standards in accordance with the specifications of the harmonized standards:

- 2014/35/EC Low voltage directive
- 2014/30/EC Electromagnetic Compatibility directive (EMC)
- 2011/65/EU (incl. 2015/863/EU) R0HS Directive

Standards as reference:

- EN-IEC 62040-1
- Uninterruptible power supply (UPS). Part 1-1: General and safety requirements for UPS's used in accessible areas by end users.
- EN-IEC 60950-1
- IT equipment. Safety. Part 1: General requirements
- EN-IEC 62040-2
- Uninterruptible power supply (UPS). Part 2: EMC requirements
- EN-IEC 62040-3
- Uninterruptible power systems (UPS). Part 3: Performance and test requirements
- 2011/65/EU
- Restriction of the use of certain hazardous substances (RoHS) DIRECTIVE

The supplier's responsibility is excluded if the customer modifies, or intervenes with, this product in any way.

	Product Standards	Standards
Safety	EC/EN 62040-1	EC/EN 60950-1
Electromagnetic Compatibility (EMC)	IEC/EN 62040-2	IEC/EN 61000-6-2
	Emission cat. C3	IEC/EN 61000-6-4
	Immunity cat. C3	IEC/EN 61000-4-2
		IEC/EN 61000-4-3
		IEC/EN 61000-4-5
		IEC/EN 61000-4-6
		IEC/EN 61000-4-8
Performance Standard	EN-IEC 62040-3	

2. General Description

2.1 Introduction

Congratulations on your purchase of the REHLKO PW 6000 (60-120 kVA) UPS.

Continuous power availability is essential in today's dynamic IT and process-related work environments. It is equally important that any installed power protection system is sufficiently resilient and adaptable to handle any requirement changes brought about by the introduction of new server technologies, migration and centralization.

Such demands are well met by the REHLKO PW 6000 (60-120 kVA) UPS system, which provides the foundation for continuous power availability of network-critical infrastructures both in enterprise data centres, where business continuity has paramount importance, and in process control environments, where manufacturing continuity is essential.

2.1.1 Reliability and quality standards

The REHLKO PW 6000 (60-120 kVA) UPS is available over a model range of 60kVA to 120kVA and incorporates the latest technological developments in power engineering. Representing a completely new generation of high power three phase UPS systems, its advanced double conversion VFI (Voltage and Frequency Independent) topology responds fully to both the highest availability and environmentally friendly requirements compliant with IEC 62040-3 (VFI-SS-111) standards.

Rehiko specialises in the installation and maintenance of Uninterruptible Power Systems; and this powerful UPS is just one example of our wide range of state-of-the-art power protection devices that will provide your critical equipment with a steady and reliable power supply for many years.

2.1.2 Key features

High reliability, upgrade-ability, low operating costs and excellent electrical performance are just some of the highlights afforded by this innovative UPS solution. Other key features include:

- *Compact size, small foot print* – Saving on expensive floor space
- *Flexible battery management* – Advanced management of battery charging and preventive failure diagnostics avoids premature deterioration of battery life
- *Best in class AC-AC efficiency, up to 96%* – Saving on energy and operational cost (TCO)
- *Low input power factor (near unity)* – Saving cabling and supply distribution costs during installation and the over the entire life cycle (TCO)
- *Blade-server-friendly power* – Full power available from 0.9 lead to 0.9 lag means that no de-rating is required with leading power factor loads and therefore no need to 'over-size' the UPS system to cater for the load.
- *Very low input current distortion THDi* – The THDi is $\leq 4.0\%$ @ 100% load, reducing the capital and installation costs of an optional standby generator if used.
- *Ease of expansion* – Additional UPS cabinets (up to a maximum of 10) can be connected to an existing parallel system without needing to disturb the load supply

2.2 REHLKO PW 6000 (60-120 kVA) model range

The PW 6000 (60-120 kVA) UPS range includes 60, 80, 100 and 120 kVA models, all of which are contained in the same size cabinet. (See Chapter 9 for a complete equipment specification.)



Mechanical Details	Unit	60	80	100	120
Photograph – front view with doors open					
Rated output power	kVA/kW	60/60	80/80	100/100	120/120
Cabinet dimensions (w x h x d)	mm	615 x 1954 x 480 without feet 615 x 1978 x 480 with adjustable feet adjusted down 615 x 1992 x 480 with adjustable feet fully extended			
Weight (excluding batteries)	kg	198	206	228	230

Figure 2.1 REHLKO PW 6000 (60-120 kVA) Model range

Within the UPS cabinet, a safety panel is fitted immediately in front of all the major UPS power components to reduce the risk of accidental shock – the terminals of the UPS mains power cables and switches are similarly protected. A further safeguard is provided by a key-lockable door fitted to the front of the cabinet to provide controlled access.



WARNING: If you remove a safety panel you will be exposed to a sever shock hazard.

The safety panel panels should be removed only by an Rehiko trained engineer.

The UPS batteries are installed in a separate cabinet or mounted in a purpose-designed battery rack.

The battery arrangement will vary from site to site depending on the battery specification and environmental requirements; however, Rehiko can provide a range of external battery cabinets to suit the vast majority of installations.

The REHLKO PW 6000 (60-120 kVA) UPS can be installed as a standalone UPS or as a multi-module, parallel UPS system comprising up to ten UPS cabinets. In a multi-module UPS system, additional modules can be added to the system (to a total of ten parallel modules) to increase the UPS system capacity when necessary – i.e. the UPS system can ‘grow’ to suit an expanding connected load. It can also enhance the overall system reliability by including module redundancy.

Note: In this manual the terms ‘multi-module system’ and ‘parallel system’ are synonymous.



Key Point: In a parallel system ALL the connected modules must be of the same output rating. For example, it is not permissible to connect 60 kVA and 120 kVA modules together in a parallel system.

2.3 UPS module functional description

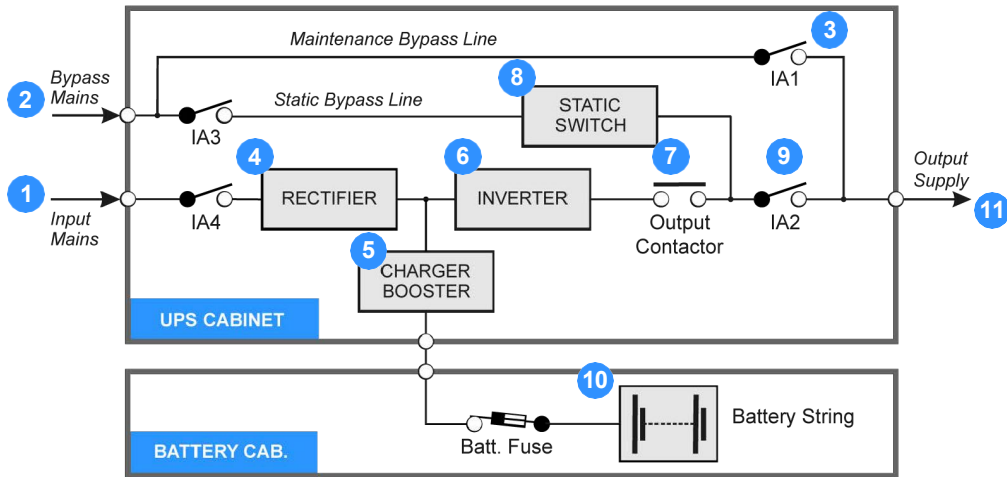

Figure 2.2 REHLKO PW 6000 (60-120 kVA) UPS module block diagram

2.3.1 UPS module block diagram

Figure 2.2 shows the major power blocks contained within the UPS system.

UPS Input supplies IA4 (1), IA3 (2)

The UPS has two sets of three-phase input supply terminals:

- The 'mains supply' (1) is connected to the rectifier power block via the input isolator (IA4).
- The 'bypass supply' (2) is connected to the static bypass line, via IA3, and the maintenance bypass line via IA1.

In practise, the bypass supply terminals (2) are often linked to the mains supply terminals (1) within the UPS cabinet so the UPS effectively requires only one mains supply connection – see paragraph 3.3.2 for details concerning 'single feed' & 'dual feed' input configurations.



CAUTION: The UPS mains supplies are not internally fused. The input supply cables must be connected via an external isolation device (fuse/circuit breaker) to provide overload protection and a means of disconnecting the mains supplies to the UPS.

Maintenance bypass switch (3)

The maintenance bypass switch (IA1) provides a means of entirely bypassing the UPS power blocks and can be used to temporarily connect the load directly to the bypass mains supply if it is necessary to fully power down the UPS for test/ repair purposes.



Key Point: When the load is connected via the maintenance bypass switch (3) it is not protected against bypass supply aberrations or total failure.

Note that the maintenance bypass switch is only rated for the individual cabinet's load, so where two or more cabinets are connected together to form a parallel UPS system the internal maintenance bypass switch (IA1) should not be used. In a parallel system an external maintenance bypass facility must be incorporated into the system design which includes a system-rated maintenance bypass switch – a typical external maintenance bypass installation is shown on page 25.

Rectifier (4)

The rectifier converts the input mains supply to a DC power source which is used to charge the batteries and provide the DC power input to the inverter. The rectifier can satisfy the full inverter DC power demand (i.e. 100% rated UPS output) over an input mains voltage range of -10% to +15%. If the input mains falls to -30% the rectifier can still provide up to 60% of the inverter load.

This wide input voltage range means that the battery is not called upon during substantial power dips (brown outs), which helps maximise the battery life and availability. The rectifier control system uses leading-edge switched-mode techniques which achieves a UPS input power factor of almost unity over its operating range (0.99 at full rated linear load).

Battery booster/charger (5)

This block has bi-directional functions. When the UPS input mains supply is available, and the rectifier is turned on, the booster/charger acts as a multi-stage battery charger which uses an intelligent charging profile which optimises the battery life and ensures the battery recharges quickly following a deep discharge cycle.

When the UPS is operating from battery power the booster/charger uses advanced DC-DC converter techniques to provide the inverter with a regulated DC input to allow it to operate correctly from battery power as the battery discharges.

Inverter (6)

The inverter converts the DC voltage produced by the rectifier (or the battery via the booster/charger) into a sinusoidal AC output voltage that is suitable to connect to the load. In addition to providing output voltage regulation, the inverter control logic also provides various levels of overload protection, frequency regulation and synchronisation, and output voltage error detection.

Output contactor (7)

The output contactor provides a controlled means of connecting/disconnecting the inverter from the UPS output. It is used in conjunction with the static switch (8) to transfer the load between the inverter and static bypass line in the event of an inverter fault or overload, and during the UPS start/stop operating procedures.

In a parallel-module system the UPS control system uses the output contactor (7) to disconnect the inverter from the parallel system output when necessary – e.g. to isolate the UPS from the parallel system in the event of an inverter fault.

Static switch (8)

The static switch is an electronically controlled, solid-state switch connected in the static bypass line. As described above, it operates in conjunction with the output contactor (7) to transfer the load between the inverter and static bypass line when necessary. The static switch control logic transfers the UPS output from the inverter to the static bypass line without a load-break in the event of an output overload or UPS (inverter) malfunction.

Parallel isolator, IA2 (9)

IA2 is a manually-operated switch that is connected directly to the UPS output supply terminals and can be used to isolate the UPS output from either the inverter (6,7) or static bypass (8). In a single-module installation, IA2 can be used to isolate the UPS power blocks to enable repair/replacement procedures to be carried out while the load is connected to the maintenance bypass line, via IA1. In a 'redundant' parallel system, IA2 can be similarly used to isolate a UPS module from the parallel system while the remaining on-line modules continue their normal operation.

Battery (10)

The bespoke UPS batteries are either installed in a dedicated battery cabinet or on a purpose-designed battery rack. As the battery cables are not fused within the UPS cabinet, the battery installation must include a fused isolator or circuit breaker located near the battery source to provide suitable DC protection and enable the batteries to be manually disconnected from the UPS.

Output (load) supply (11)

Figure 2.2 shows that the UPS output (load) supply can be provided through one of three power paths from within the UPS, depending on the UPS operating mode:

- From the inverter (3) – via the output contactor (7) and the output isolator (IA2).
- From the static bypass line – via the static bypass isolator IA3, the static switch (8) and the output isolator (IA2).
- From the maintenance bypass line – via the maintenance bypass isolator (IA1).

Only one of these output supply sources can be active at any given point in time and the criteria for operating under each of these UPS modes is described below.

2.3.2 UPS internal operating modes

The following simplified block diagrams illustrate various UPS operating modes.

Load on Inverter

This is the normal operating mode for an on-line UPS and is the only mode that provides the load with continuously processed and backed-up power.

In this mode, the input mains supply is converted to DC by the power rectifier which then charges the battery and provides the operating power for the inverter. The inverter converts the 'DC busbar' produced by the rectifier back to an AC supply that is suitable to power the load.

The output contactor connects the inverter to the UPS output supply terminals (via IA2) and is able to quickly disconnect the inverter output in the event of an inverter fault or overload.

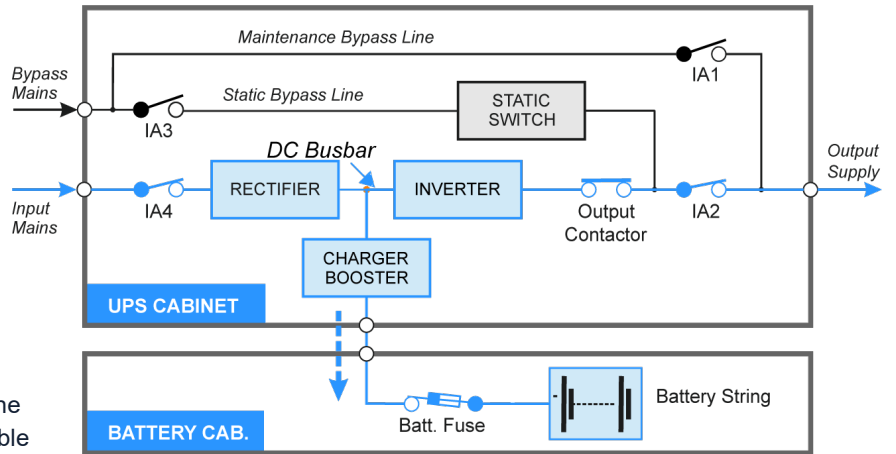

Figure 2.3 Load on inverter

The AC waveform produced by the inverter is synchronised to the bypass supply provided the bypass supply frequency remains within preset limits (usually set to ± 1 Hz).

Load on Battery

If the input mains supply fails, or undergoes a significant voltage dip, the rectifier is unable to provide sufficient power to sustain the inverter output and under these circumstances the battery provides an alternative DC power source.

Using battery power, the 'charger/ booster' power block regulates the DC busbar at the same voltage that was previously provided by the rectifier and the changeover of DC busbar power source is totally transparent to the inverter, which will continue to operate until the battery is discharged.

If the bypass supply is unavailable when the inverter is operating from battery power, the inverter frequency is controlled by a free-running oscillator that maintains the output frequency at a constant 50/60 Hz.

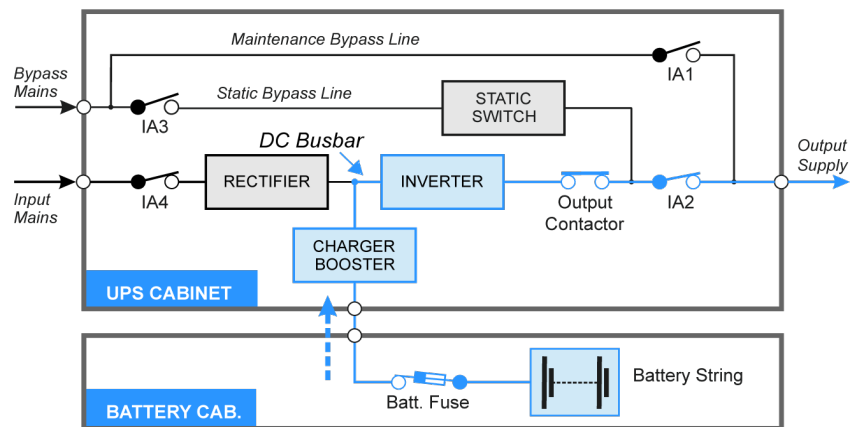

Figure 2.4 Load on inverter (from Mains or Battery power)

An alarm is activated to warn the operator that the UPS is operating on battery power and a further alarm is triggered if the battery discharges to a preset 'low-battery' level. The 'low battery' alarm is generated sufficiently early to enable the operator to shut down the load in an orderly manner if necessary (e.g. to save data) before the battery eventually reaches its 'end-of-discharge' voltage, whereupon the UPS shuts down. Various options are available to automate the load shut-down process, as described in Chapter 8 of this manual (Options).

In practice, especially in larger UPS installations, the overall UPS system often includes a standby generator which starts automatically in the event of a mains supply failure and provides an alternative UPS input supply source until the utility mains supply returns to normal. In this scenario the battery is only required to support the inverter (load) until the generator comes on-line, and as a modern generator can be automatically started very quickly this results in a relatively short battery discharge period – which helps to prolong the battery life.

Load on-bypass

In the load 'on bypass' mode the UPS output supply is connected to the unprocessed static bypass line via the static switch.

This mode is invoked automatically if there is an inverter problem, or overload, which prevents the inverter from producing its correct output. It is also the normal mode of operation when the UPS is used in its 'ECO' mode.

Depending on circuit conditions, when operating in this mode the rectifier and charger sections can be turned off entirely or remain running and continue to provide battery charging. Similarly, the inverter can also remain operating on standby ready to be brought back into use.

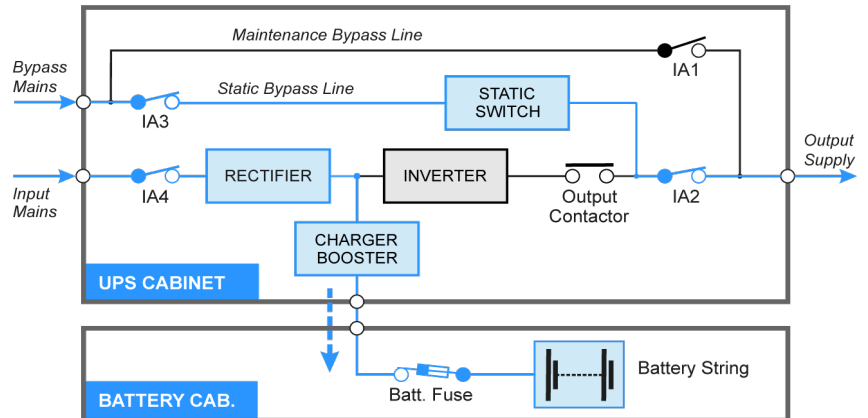

Figure 2.5 Load on bypass

Inverter/Bypass load transfer

As illustrated in the above diagrams, the UPS output supply can be connected to the inverter by means of the output contactor or to the static bypass line by means of the static switch. If both these devices are closed simultaneously it would feed the bypass mains supply back into the inverter output and inevitably result in UPS damage. Therefore the operation of the output contactor and static bypass is electronically controlled by the UPS load transfer mechanism such that their closure is mutually exclusive and the load is transferred between them as quickly as possible to avoid any significant load supply break.

Load on maintenance bypass

In this mode of operation the manually closed maintenance bypass switch (IA1) connects the UPS output directly to the bypass mains supply.

This mode is generally only used to keep the load supplied (albeit without any power protection) whilst allowing the remainder of the UPS to be shut down for service repair.

Note that when operating in the maintenance bypass mode live voltages are still present on the UPS input and output power terminals and power switches.

As with the static bypass I describe above, it is important that to avoid inverter damage the maintenance bypass and inverter output are never connected in parallel. The UPS control system includes an interlock which prevents this from occurring; however, when transferring from the 'load on inverter' to the 'load on maintenance bypass' mode it is important that the load is first transferred to the static bypass ('load on bypass') before the maintenance bypass switch is closed.

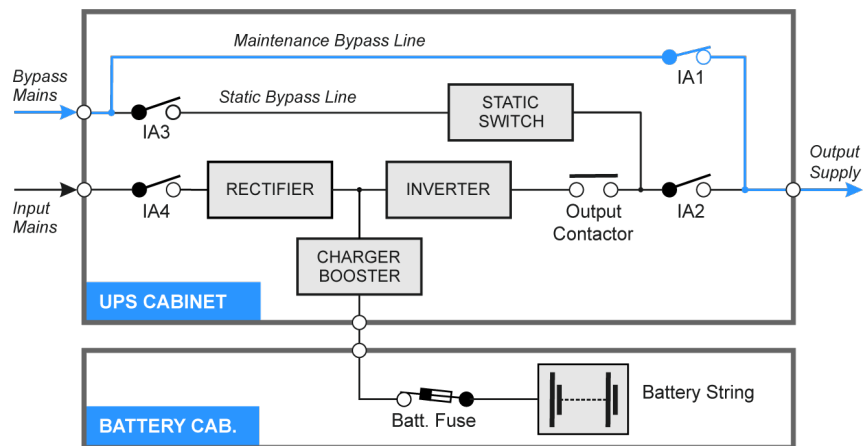

Figure 2.6 Load on maintenance bypass



CAUTION: Always follow the operating instructions in Chapter 5 of this manual when starting or shutting down the UPS.

2.3.3 System operating modes

Paragraph 2.3.2 described the various UPS internal operating modes: but UPS systems are also categorised according to the way in which they operate at a 'system' level, and are typically described as being either an 'on-line', 'off-line' or 'line interactive' UPS system. The REHLKO PW 6000 (60-120 kVA) can be operated in all three of the above categories.

On-line operation

When used as an 'on-line' UPS the REHLKO PW 6000 (60-120 kVA) module is configured to normally operate in the ON INVERTER mode.

In the unlikely event of an inverter fault, or during an overload, the UPS will transfer the load to the static bypass (ON BYPASS mode) automatically and without interruption (transfer time = 0). If the transfer is due to an output overload the system will transfer back to the ON INVERTER mode if the overload clears and the UPS will return to its normal operation.

Operating in the 'on-line' mode offers the greatest degree of load protection, especially in the event of a mains disturbance or failure, and is always recommended if the critical load will not tolerate even a very brief supply interruption.

Off-line (line interactive) operation

When the REHLKO PW 6000 (60-120 kVA) is used in an 'off-line' or 'line-interactive' system the UPS module(s) normally operated in the ON BYPASS mode, with the load being supplied from the static bypass supply. However the rectifier and battery charger are still powered up to maintain battery charging and the inverter is turned on but operating on standby.

In the event of a bypass supply error, or total failure, the load is automatically transferred to the inverter (ON INVERTER) by the static switch within 3 to 5 milliseconds. If the input mains supply is unavailable when the transfer takes place the inverter will support the load operating from battery power (ON BATTERY), as described above. If the bypass supply then returns to normal the load is transferred back to the static bypass and the inverter returns to standby.

This mode of operation is slightly more energy efficient than the 'on-line' mode due to the reduced rectifier/inverter losses during normal operation; and it is sometimes referred to as the "ECO" mode. However this mode is recommended only if the connected load equipment can tolerate power interruptions of 3 to 5 ms during the transfer period.



WARNING: The on-line system mode should always be used for critical load protection.

2.4 Multi-module parallel UPS system

2.4.1 Parallel system concept

The output from up to ten REHLKO PW 6000 (60-120 kVA) UPS cabinets can be connected in parallel for increased capacity or redundancy operation.

A REHLKO PW 6000 (60-120 kVA) parallel system has what is described as a Decentralised Parallel Architecture (DPA) in that each UPS cabinet contains its own static bypass and static switch. This removes the need for a separate bypass cabinet, as required by some manufacturers' systems. DPA offers two major advantages:

- It eliminates a potential single point of failure that is inherent in a system that includes a separate bypass cabinet.
- It allows a parallel module system to be expanded more simply – without having to consider the effects of any expansion on a separate bypass cabinet capacity.

System expansion

Most data centres present a low initial power demand which increases as the data centre grows to its full capacity. So it is essential that any installed power protection system can be expanded to meet the growing demand without compromising the existing load. This situation is easily managed in a PW 6000 (60-120 kVA) multi-module installation, which allows an additional module to be installed in an existing parallel system without having to temporarily transfer the load to the raw by-pass mains supply. This results in the load receiving UPS protected power at all times during the upgrade process – without interruption.



Key Point: If a REHLKO PW 6000 (60-120 kVA) module is purchased as a standalone, single unit UPS it will require a field upgrade to make it suitable for parallel operation at a later time. For this reason, if you know that your load is likely to expand in the future it is advisable to install a parallel-capable module at the outset.

Module redundancy

A multi-module system with inbuilt module redundancy contains at least one UPS module over and above that required to provide the specified system full load power.

For example, a PW 6000 system comprising 3 x 100 kW modules can be employed as a redundant module system for a load of up to 200 kW. In this case, under normal circumstances all three modules will share the load equally and each supply up to 66.6 kW at full load; but if one module fails, or is shut down, the two remaining modules can sustain the load by each supplying their fully rated 100 kW. The ability to lose one module yet still supply the full load with processed, backed-up power significantly increases the overall system reliability.

If an additional 100 kW load is added to the example system above at a later date the system will operate as a 'capacity' system, requiring all three modules to be available to provide a protected system; however, by adding a fourth module it will once again operate as a redundant module system.

Once again, the PW 6000 module DPA architecture enables additional modules to be connected to the parallel system at any time without having to disturb the load.

2.4.2 Parallel UPS system operation

In a multi-module parallel system the topology and internal operation of each UPS module is identical to that described previously for a stand-alone module. However, when operating as part of a parallel system an additional control layer is required to cater for critical 'system level' control functions such as load sharing, frequency synchronisation and load transfer, which must be observed by all the on-line UPS modules. This is achieved in the PW 6000 UPS system by connecting a 'parallel control bus' between the UPS modules in a daisy-chain fashion to allow them to communicate with each other continuously and execute all necessary synchronous control operations.

System-wide load transfer operation

All the modules connected as a parallel system must be working in the same internal mode of operation at all times – i.e. it is not permissible for one module to operate in the 'load on inverter' mode while the remaining modules are in the 'load on bypass' mode – such a situation would almost inevitably result in damage to the modules' inverter.

In a parallel system therefore, if you activate the `LOAD TO BYPASS` command *on any one module* then all the modules will simultaneously switch to the 'load on bypass' mode. Conversely, when operating on bypass if you select the command `LOAD TO INVERTER` *on any one module* then all the UPS modules will simultaneously transfer the load to their inverters – provided a sufficient number of modules are operating to feed the connected load.

Inter-module frequency synchronisation and load sharing

Frequency and current sensing signals are passed over the parallel control bus to enable each UPS module to compare its own frequency and output current with that of its neighbour. This allows each module's control logic to effect any fine adjustments necessary to achieve balanced conditions.

The parallel control logic always observes one of the modules as being the 'master' and the other module(s) as 'slaves'. However if the 'master' module goes faulty at any time the next module in the chain (a former 'slave') will immediately take over the 'master' role, and the former 'master' module will turn off. Master/slave relationship is configured during commissioning and should not be modified by the user.

Isolating a module from the system

If a parallel system incorporates module redundancy a module can be isolated from the system for service/repair purposes without affecting the operation of the remaining modules or load.

Every module has a parallel (output) isolator (IA2) which can be used to disconnect the module's output from the load bus. When IA2 is open there is no load power being drawn from the module and it can be shut down in the normal way using the ON/OFF

buttons on the UPS control panel; but in this case using these buttons will shut down the associated module only and will not cause the remaining modules to shutdown or transfer the load to bypass.



WARNING: When the UPS module is shut down its output terminals will be live even if the module's input mains and batteries are isolated.

2.4.3 Common battery

It is permissible to connect two or more UPS modules to a common battery to allow them to share the battery charging. However, by employing a separate battery bank for each module you avoid a potential single point of failure and thereby increase the overall system reliability by extending the system redundancy to include the batteries. We highly recommend the use of individual batteries for each module

2.5 REHLKO PW 6000 (60-120 kVA) User Controls

2.5.1 Power isolators

The REHLKO PW 6000 (60-120 kVA) UPS power isolators, shown in Figure 2.7, are used by the operator when starting and shutting down the UPS in accordance with the operating procedures provided in this manual.

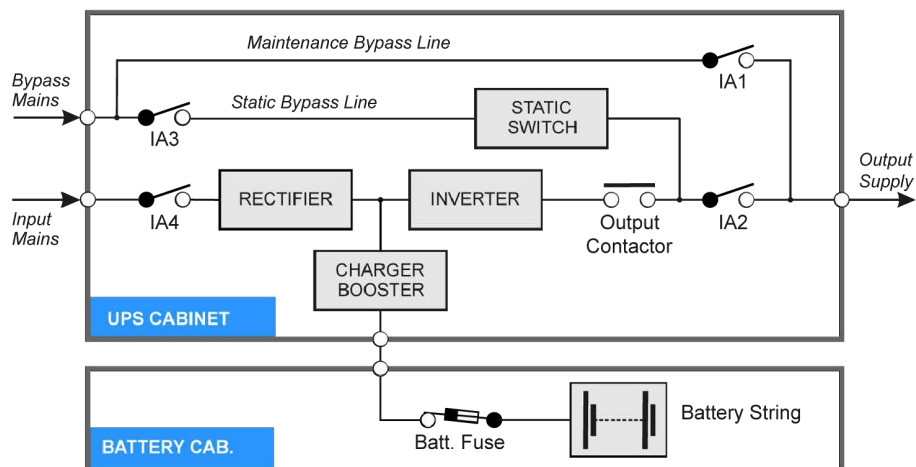
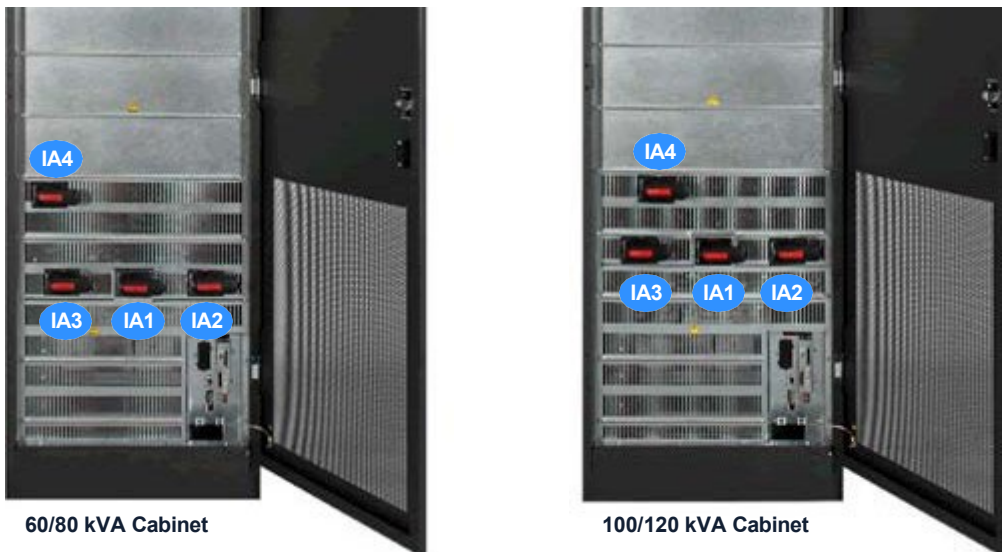

Figure 2.7 REHLKO PW 6000 (60-120 kVA) power isolators

2.5.2 UPS Control panel

An LCD control panel located on the front of the cabinet provides the means for day-to-day UPS operation and performance monitoring.

From the UPS control panel the operator can:

- Stop and start the UPS module.
- Transfer the UPS output (load) between the inverter and bypass.
- Monitor the UPS input/output voltage, current and frequency.
- Monitor the battery charge/discharge current and battery status.
- Interact with monitored alarm and warning messages.
- Configure the UPS operating parameters (service mode).
- Interrogate the UPS operating events and alarm history (service mode).
- Carry out diagnostic procedures (service mode).

2.6 LCD Control Panel

The LCD control panel has three areas, described below:

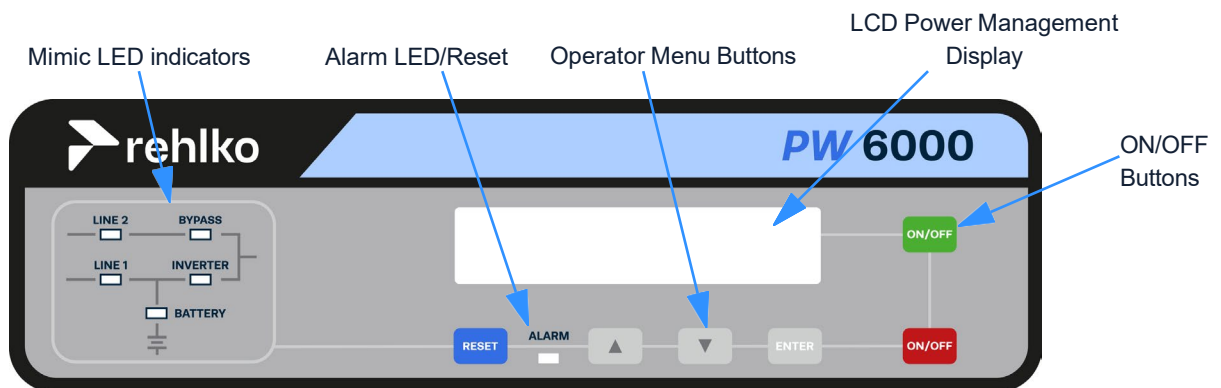

Figure 2.8 LCD Control panel

2.6.1 Module mimic LED indicators

The module mimic LEDs change colour between GREEN, RED and OFF to indicate the operational status of key UPS stages, and thereby serve to show the active power path through the UPS.

- LINE 1 (rectifier) and LINE 2 (bypass) LEDs indicate the availability of the input mains and bypass mains supplies respectively.
- INVERTER and BYPASS LEDs illuminate green to indicate which of the two sources is providing the UPS output supply.
- BATTERY illuminates green when the battery is being charged and flashes when the battery is discharging – e.g. when supplying the load following a mains failure. The indications change to red if the battery is faulty or fully discharged.
- The ALARM LED, located at the bottom centre of the control panel, provides a visual indication that an internal or external alarm condition has been detected. When an alarm condition is activated the LED is accompanied by an audible alarm.

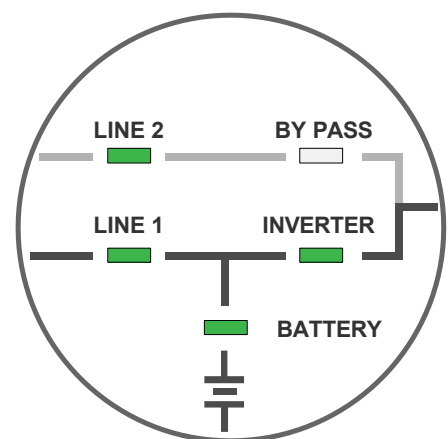

Figure 2.9 Module mimic diagram

LED Indication summary

INDICATOR	STATUS	INTERPRETATION
LINE 1	GREEN RED	Input Mains available Input Mains not available (Normal display during an input mains power failure)
LINE 2	GREEN RED	Bypass Mains OK Bypass Mains not OK (Bypass not present or bypass voltage / frequency error)
ALARM	OFF RED + buzzer RED	No alarm condition Alarm condition Alarm condition (has been reset)
INVERTER	OFF GREEN RED	Inverter turned OFF or load on bypass Load on inverter Inverter in unavailable, or locked out
BYPASS	OFF GREEN RED	Bypass not operating (Module is OFF or load on inverter) Load on bypass Static bypass is unavailable, or locked out
BATTERY	GREEN Flashing GREEN RED Flashing RED	Battery charger is ON and the battery is OK Load on battery and battery is discharging (Normal display during input mains failure) Battery faulty or discharged (High voltage, high temperature, failed battery test) Battery not detected. Battery is disconnected or fuse open, low battery voltage, (Note this is the default status before turning on the module).

2.6.2 Operator buttons

The operator buttons allow the user to:

- Set operating parameters and make adjustments via the menu-driven LCD display.
- Start and stop the UPS, and transfer the load between inverter and bypass.
- Monitor the UPS input/output voltage, current, frequency and other parameters – shown on the PMD display.

Button function summary

BUTTON	FUNCTION
ON/OFF	Used to switch-on or switch-off the UPS
UP(▲)	Scroll upwards through a displayed menu
DOWN(▼)	Scroll downwards through a displayed menu
RESET	Cancels the audible alarm. If the alarm condition was transient the ALARM LED will also extinguish, otherwise the LED will remain ON (red)
ENTER	Confirms (selects) a chosen menu item

ON/OFF Buttons

The UPS can be switched ON or OFF by simultaneously pressing both ON/OFF buttons. The requirement to press both buttons is to help avoid accidental operation.

During normal operation, simultaneously pressing the two ON/OFF buttons will shut down the UPS module.

- In a standalone (single unit) installation this will disconnect the UPS output unless the load is first transferred to the maintenance bypass – see the operating instructions.
- In a parallel module system the UPS module will shut down and its output will be disconnected from the parallel load bus. However, the load may or may-not transfer to bypass depending on the number of remaining live modules – i.e. if the number of remaining modules is sufficient to support the connect load then the load will not be transferred.

To shut down all the modules in a parallel system you must press both ON/OFF buttons on every module.

2.6.3 Power Management Display (PMD)

Working in conjunction with the UP, DOWN and ENTER buttons, the LCD screen at the centre of the power management display presents a range of selectable menus which allows the user to operate the UPS and monitor its performance – the menu tree is shown in Figure 2.10.

Status screens

During normal operation the LCD displays a default UPS status screen similar to those shown below. From the status screen the user can access the 'top level' menu by pressing the UP or DOWN button; and then further navigate through the nested sub-menus using the UP or DOWN buttons to scroll, and the ENTER button to make a selection.

This status screen indicates that the UPS is operating 'on inverter' and providing protected power to the load.

LOAD PROTECTED	P01
-------------------	-----

This status screen indicates that the UPS will not support the load during a power failure, examples include 'on bypass' or batteries disconnected

LOAD NOT PROTECTED	P01
-----------------------	-----

This status screen indicates that the load is not being powered from the UPS, usually because the UPS has been switched off by the ON/OFF buttons.

LOAD OFF SUPPLY FAILURE	P01
----------------------------	-----

This status screen indicates that the UPS parallel switch (IA2) is open and the UPS module is disconnected from the parallel system. Although in a redundant parallel system the load might still be receiving protected power from the remaining on-line modules.

LOAD DISCONNECTED PARALLEL SWITCH OPEN	P02
---	-----

On the right hand side of the LCD-Display is a three digit indicator which shows the module's position in a multi-module system (maximum number of modules is 10).

- S Stands for **S**ingle unit. The UPS system comprises only one cabinet.
- P01 Stands for **P**arallel system and 01 identifies the cabinet as the 1st module (MASTER) in the system.
- P02 Stands for **P**arallel system and 02 identifies the cabinet as the 2nd module (SLAVE) in the system. This number can range from 02 to 10 depending on the cabinet's position in the parallel system.

Top level menu

The following sub-menus can be accessed from the top level menu:

EVENT LOG – The event log stores the last 64 UPS events in date/time stamp order. These include both 'fault' events, such as [OVERLOAD], and 'operational' events such as [LOAD TO BYP.].

MEASUREMENTS – This sub menu provides access to a range of input, output and battery parameter metering.

COMMANDS – This sub menu provides access to a range of commands that might be used during day-to-day UPS operation. Those most commonly accessed are the [LOAD TO INVERTER] and [LOAD TO BYPASS] command which are used to transfer the load between inverter and bypass during the UPS start-up and shut down procedures.

[PERFORM BATT. TEST] Stops the charger and monitors the off-load battery voltage for 1 min. then transfers the load to battery for a further 1 min.

[PERFORM DEEP BATT. TEST] Performs as above, but runs with battery on load until the low voltage alarm activates.

SET-UP DATA – This is a read-only menu and shows the UPS details input by the manufacturer/commissioning engineer.

[DYNAMIC PASSWORD] is normally set to NO

SET-UP USER – This sub menu allows the user to select the LCD display language, set the local date/time used to stamp the Event Log, set up the automatic battery test operation and configure the UPS options when running on standby generator.

SET-UP SERVICE – This menu is used by the commissioning engineer and is password-protected to restrict access.

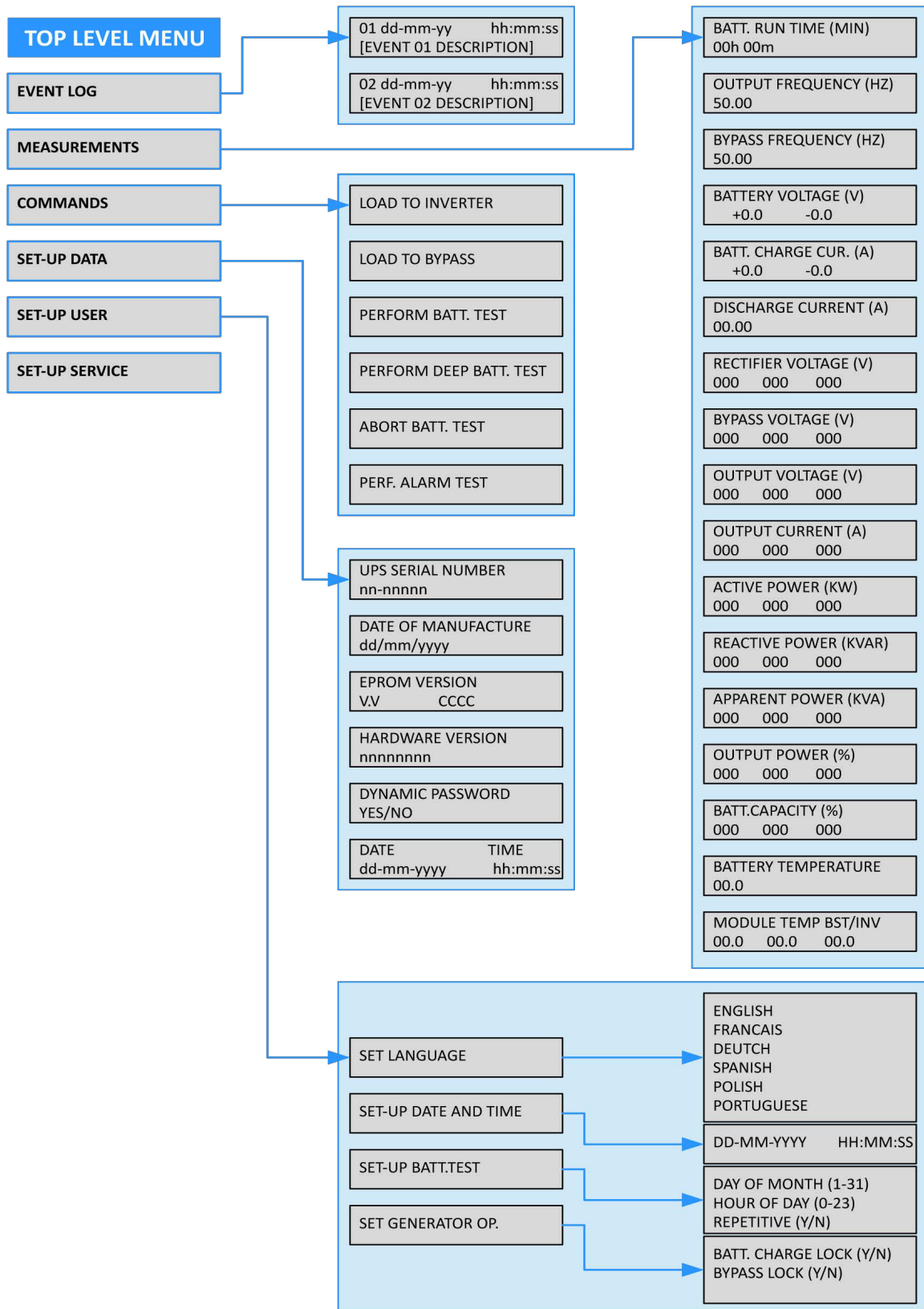

Figure 2.10 Module control panel menus

2.7 UPS Communication interface

The UPS provides several input/output communication interface options that can be used for remote monitoring and control purposes, together with the inter-module 'parallel bus' connections that are necessary in a multi-module system.

All connections are available via the Communication Interface Board, which is located in the front, lower right-hand corner of the UPS cabinet.

Figure 2.11 shows a photograph of the Communication Interface Board with the Parallel Adapter Board (L) fitted. A detailed explanation of the interface facilities is provided in the Options chapter of this manual.

A	SLOT 2 – for optional USB and Relay card. Provides customer outputs.
B	*JD6 – Parallel Adapter Board output cable to the next module in the parallel chain.
C	*SW2-2 – Parallel configuration DIP switch located on Parallel Adapter Board (set by the commissioning engineer)
D	*JD5 – Parallel Adapter Board input cable from the previous module in the parallel chain.
E	Multi cabinet configuration DIP switch (set by the commissioning engineer)
F	SW2 – Multi-Drop configuration switch (set by the commissioning)
G	Multi-Drop (RJ45) – used to interconnect parallel modules to allow the system to be remotely monitored over Ethernet.
H	X1 – Customer inputs via Phoenix terminals.
I	LEDs – red and green leds indicate the Customer Interface Board operational status.
J	JD1 – RS232 user interface to PC for monitoring and control purposes.
K	SLOT-1 – Optional SNMP card interface facility.
L	*Parallel Adapter Board

**This photograph shows the Parallel Adapter Board (L) installed. This board is used only in a parallel system and plugs into JD8 on the Communication Interface Board. It is secured in place by 2 screws, as shown.*

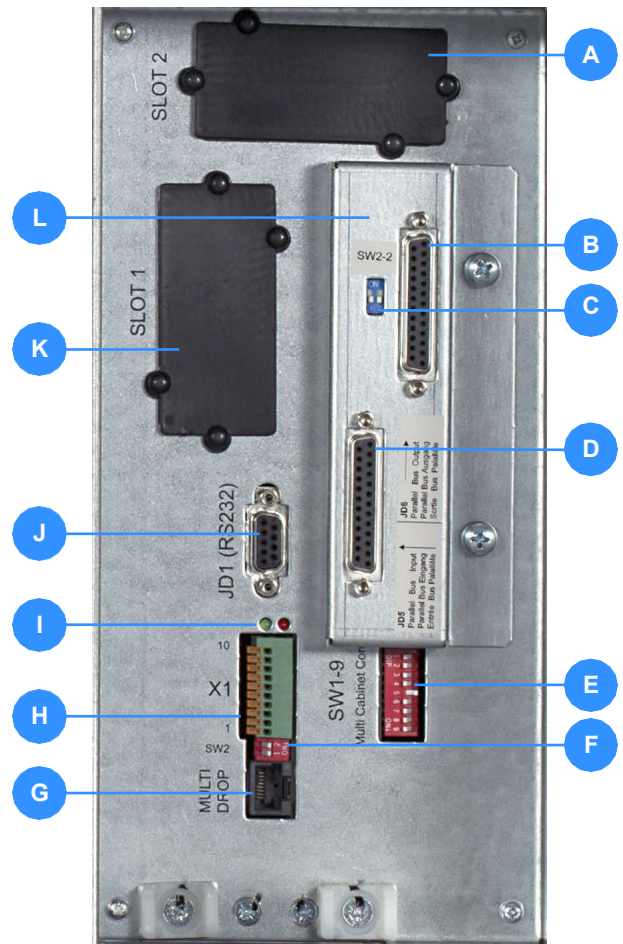

Figure 2.11 Communication interface facilities

3. Installation Planning

3.1 Introduction

A certain amount of pre-planning will help ensure a smooth and trouble-free UPS installation process. This chapter contains essential information concerning the environmental, mechanical and electrical requirements that should be considered when planning the installation of the REHLKO PW 6000 (60-120 kVA) UPS system.



Key Point: If you are installing an external battery cabinet supplied by Rehiko you should refer to the manual that is provided with the cabinet for installation instructions.

3.2 Environmental and mechanical planning

3.2.1 Environmental considerations

It is essential that the following environmental guidelines are observed when planning a suitable UPS location and operating environment.

1. The route to the installation location must allow the equipment to be transported in an upright position.
2. The floor at the proposed installation site and en-route from the off-loading point must be able to safely take the weight of the UPS and battery equipment plus the fork lift during transit.
3. Locations with high ambient temperature, moisture or humidity must be avoided.
 - a. The installation site humidity should be <95% non-condensing.
 - b. The prescribed equipment ambient temperature is 0°C to +40°C.
 - c. A battery temperature of 20°C to 25°C is recommended to achieve a long battery life.
 - d. The air conditioning system must be able to provide a sufficient amount of cooling air to keep the room within the prescribed temperature range.
 - e. The air entering the UPS must not exceed +40°C.
4. To obtain the best system performance the following environmental conditions should also be considered:
 - a. Fire protection standards must be respected.
 - b. The location must be free of dust and corrosive, or explosive, gases.
 - c. The location must be vibration free.
 - d. If the UPS is located in bayed enclosures, partition walls must be installed.
 - e. The minimum cabinet clearances described below must be provided.

3.2.2 Installation clearances

Figure 3.1 illustrates the clearances required when installing a single or multi-module REHLKO PW 6000 (60-120 kVA) UPS system. The top illustrations show a single-module installation and a four-module parallel system installed as an equipment suite including an adjacent CBAT 150T battery cabinet.



Key Point: The CBAT 150T battery cabinet is recommended by Rehlko for use with the REHLKO PW 6000 (60-120 kVA) system. If an alternative battery cabinet is used then the dimensions shown in Figure 3.1 must be adapted to suit the recommendations of the particular battery cabinet manufacture.

The lower illustration shows a four-module parallel system installed with a 'remote' battery enclosure.

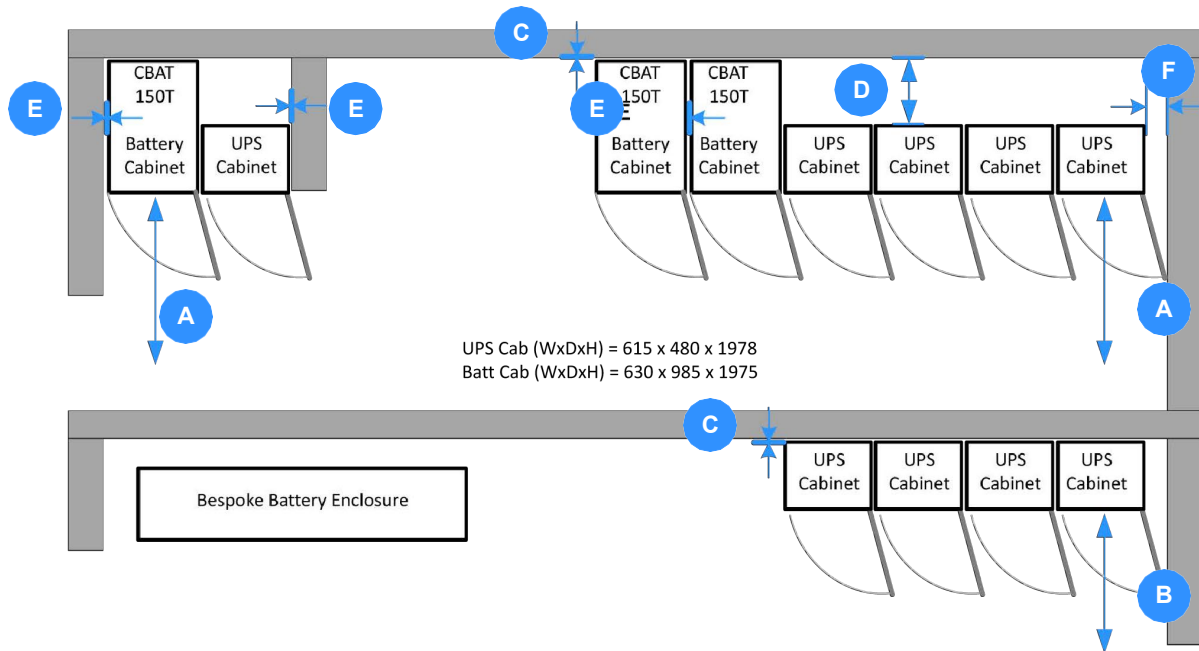

Figure 3.1 Installation clearances

Top clearance (ventilation)

The UPS is force-cooled by conditioned air which enters the cabinet through the ventilation grills in the cabinet door and then extracted by roof-mounted fans.

- A minimum of 400 mm must be provided above the UPS cabinet to allow an adequate extracted air flow.
- Consideration should also be given to ensure that the ventilation grills on the cabinet doors and top of the cabinet are not likely to be obstructed.

Front clearance (A),(B)

The CBAT 150T battery cabinet requires a minimum of 1200 mm front clearance (A) to allow access its battery trays

- When installing a UPS 'suite' with the UPS cabinets aligned with the front of the CBAT 150T this front clearance (A) also applies to the UPS cabinets.
- If the battery is installed in a remote enclosure the UPS cabinet front clearance can be reduced to 1000 mm (B). *Note: These are the specified 'minimum' clearances. Where possible, these clearances should be ideally increased to allow safe passage in front of the UPS with the doors open.*

Rear clearance (C),(D)

No rear clearance is necessary for cabinet ventilation purposes, and rear access is not required to install, connect or operate the UPS. Therefore, the cabinet can be installed directly against a wall or partition where appropriate (C). Where this is

the case, you should pre-install the power and control cables to ensure that they are fully accessible once the UPS is fixed in its final position.

Where the UPS cabinet is installed adjacent to the CBAT 150T battery cabinet a rear clearance of 505 mm (D) is applied to align the front of the cabinets.

Side clearance (E),(F)

The CBAT 150T battery cabinet and UPS cabinet do not require any side clearance, so they can be installed immediately adjacent to each other or partition/wall (E). However, it is necessary to open the cabinet door to 115° to fully access some internal components, so, if the cabinet is installed adjacent to a partition or wall that extends beyond the front edge of the cabinet a right side clearance of 100 mm (F) should be provided to allow the door to open fully.

Note: If it is not possible to apply the additional right-side clearance the doors have been designed to be easily removable to aid internal access when needed.

Battery installation

Although a CBAT 150T battery cabinet is shown in Figure 3.1, the design of the battery installation is bespoke to the individual site. However, we recommend that where possible the battery is contained in a purpose-designed cabinet installed immediately adjacent to the UPS cabinet. It can be positioned on either side of the UPS cabinet but ideally it should be installed to the left of the UPS to minimise the length of the interconnecting DC cables.



Key Point: Although the CBAT 150T cabinet does not require any side or rear clearance for ventilation purposes, this may differ with other battery cabinet designs.

If the battery is to be mounted in an external battery rack rather than in a battery cabinet, we recommend that the battery installation is as close as possible to the UPS cabinets to minimise the length of the DC cable runs. The battery cables must be sized to compensate for the DC voltage drop between the battery installation and UPS.

Contact Rehiko for installation advice and support if necessary.

3.3 Electrical and cabling planning

3.3.1 General requirements

The information in this section should help with the preparation and planning of the UPS power cabling.

IMPORTANT NOTE:

The UPS does not contain internal fuse protection for the bypass mains, input mains (rectifier), or battery cables. It is the customer’s responsibility to ensure that external supply fuses (or other protective devices) are correctly sized to provide the recommended level of UPS protection. We also recommend that a spare set of fuses are held locally to ensure they are readily available if required.

The UPS input mains and bypass mains terminals should be connected to the utility mains supply through a LV-Distribution board that contains suitable circuit breakers or fused isolators. These are necessary to provide a means of isolating the UPS from the mains supply when required and provide suitable overload protection. Similarly, the UPS output supply terminals should be connected to the load equipment via a fused load distribution board.

Input neutral grounding

A permanently connected input neutral is required to enable the rectifier to operate correctly and allow the UPS to function properly. The input neutral must also be grounded to ensure correct operation when the UPS is running on battery.



Key Point: As the input neutral must be unswitched and connected to the UPS at all times, a 4-pole input switch or isolator must not be used at the LV Distribution board on a TN-S system.

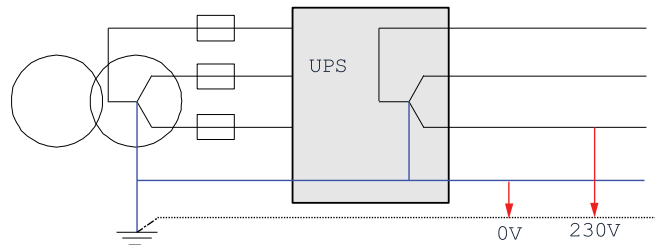

Figure 3.2 Input neutral grounding

External Backfeed protection

A UPS shall prevent hazardous voltage or hazardous energy from being present on the UPS input AC distribution after interruption of the input AC power. This is achieved by mandatory backfeed protection. Unless optional internal protection is included in UPS frame, such protection shall be provided by others and be installed as part of building installation. The backfeed protection shall be implemented in the form of an air gap, separating the upstream circuit from UPS when AC input fails. This is typically achieved through a contactor installed over the common AC input line or over each separate AC input line. Preferred location is just after the overcurrent protective devices serving each UPS input line. Such contactors shall have the coil supplied by the AC upstream circuit, to be engaged when AC upstream voltage is ON or dis-engaged when AC upstream voltage is OFF.

Specifications:

The device shall be three-poles, creating an air gap of at least 3 mm.

The thermal current shall meet the external overcurrent protection’s rating described in the coming sections.

Electrical contractor is required to attach following “Voltage backfeed warning label” as close as possible to the external isolator:

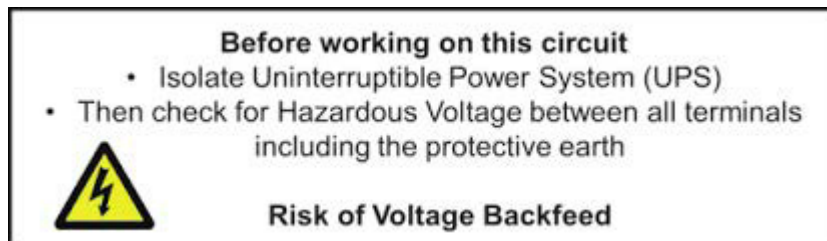

3.3.2 Cable and fuse sizing

Single feed / Dual feed inputs

The UPS can be wired for a 'single feed' input (standard), whereby the UPS input mains terminals and bypass mains terminals are internally linked; or it can be wired for a 'dual feed' input, where the UPS bypass terminals are connected to a dedicated bypass mains supply.

These configurations are shown in Figure 3.3 (single feed) and Figure 3.4 (dual feed), together with a table showing the maximum current requirements of the input mains, bypass mains, and UPS output cables. It is left to the customer to select and provide suitable cables and protective devices in accordance with national and local regulations.



Key Point: All external fuses, isolators and power cables must be rated and installed in accordance with the prescribed IEC standards or local regulation – e.g. BS7671.

Battery fuses and cables

Figures 3.3 and 3.4 do not show battery fuse and cable sizing details as these are bespoke to the installation. The DC cables and fuses will be provided by Rehlko but it is the customer's responsibility to provide any necessary cable containment. The following table is provided for information only.

UPS Rating	Fuse E (Ig/CB)	Cable E (Qty x mm ²)
60 kVA	2x 160A	2x (1x 50)
80 kVA	2x 200A	2x (1x 95) for 42-45 battery blocks 2x (1x 70) for 46-50 battery blocks
100 kVA	2x 250A	2x (1x 120) or 2x (2x 50) for 42-45 battery blocks 2x (1x 95) for 46-50 battery blocks
120 kVA	2x 300A	2x (1x 150) or 2x (2x 50) for 42-45 battery blocks 2x (1x 120) or 2x (2x 50) for 46-50 battery blocks

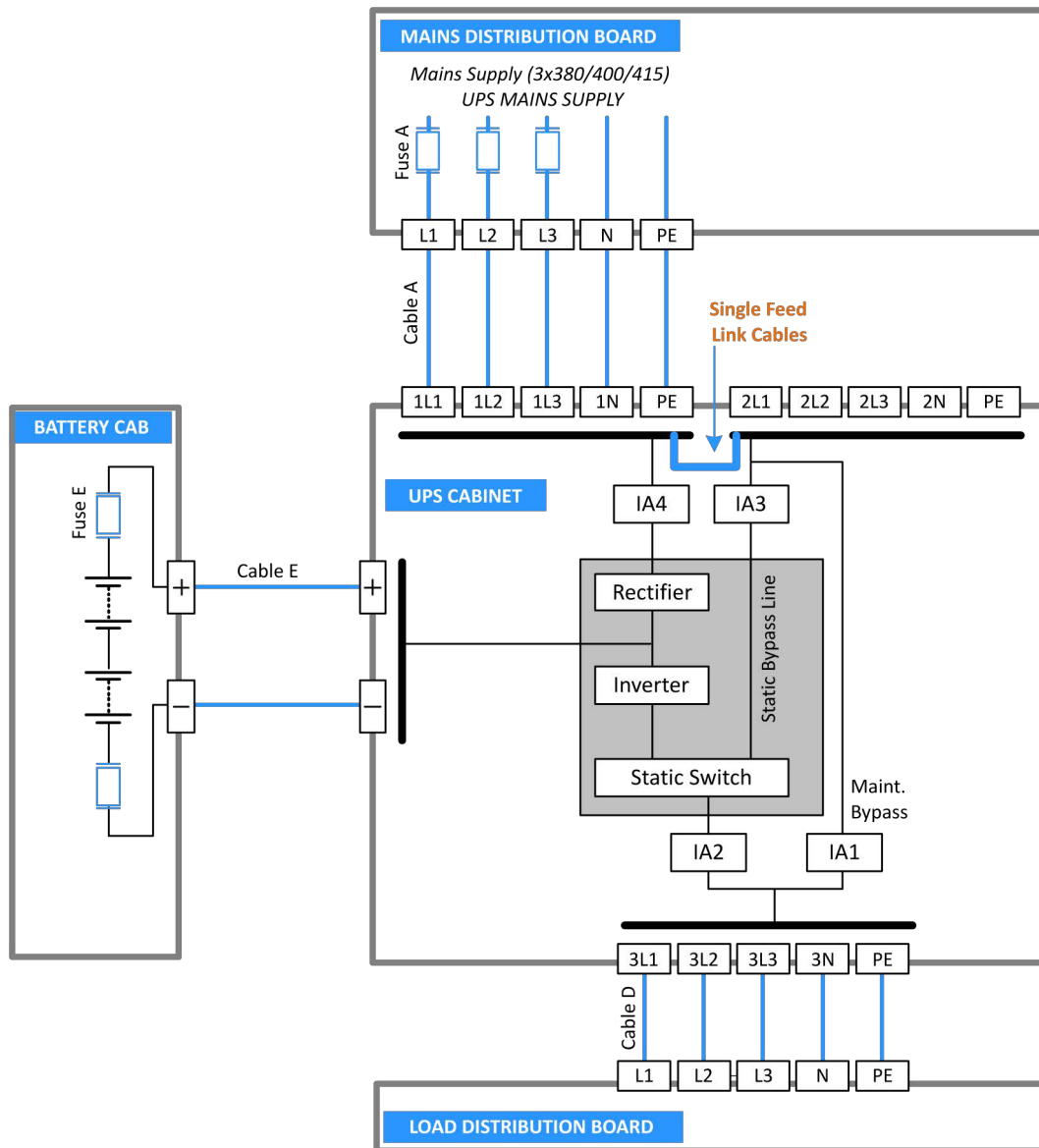

UPS Rating	Max. Input Demand (Cable A)	Max. Output Demand (Cable D)
60 kVA	101A	87A
80 kVA	134A	116A
100 kVA	167A	145A
120 kVA	201A	174A

The customer must provide:
Fuse A and Cable A Cable D

Figure 3.3 Single feed input fuse and cable ratings

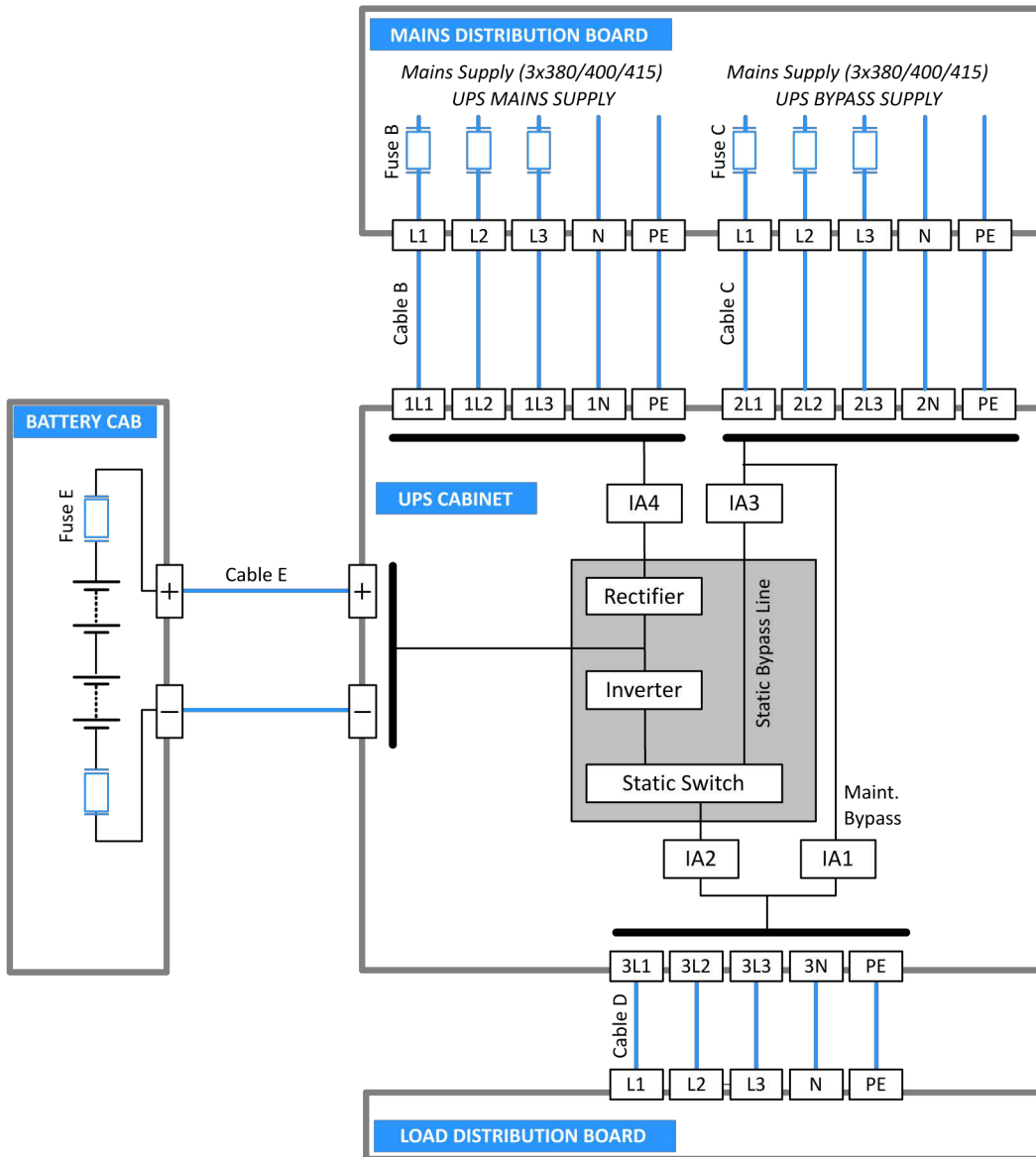

UPS Rating	Max. Input Demand (Cable B)	Max. Bypass Demand (Cable C)	Max. Output Demand (Cable D)
60 kVA	101A	87A	87A
80 kVA	134A	116A	116A
100 kVA	167A	145A	145A
120 kVA	201A	174A	174A

The customer must provide:

- Fuse B and Cable B
- Fuse C and Cable C
- Cable D

Figure 3.4 Dual feed input fuse and cable ratings

3.3.3 Power cabling in a parallel system

To achieve equal load sharing between the UPS cabinets in a multi-cabinet installation, the input cables from the mains distribution board to each UPS cabinet should be of equal length. Similarly, the length of the UPS output cables to the load distribution board should be of equal lengths (see Figure 3.5).

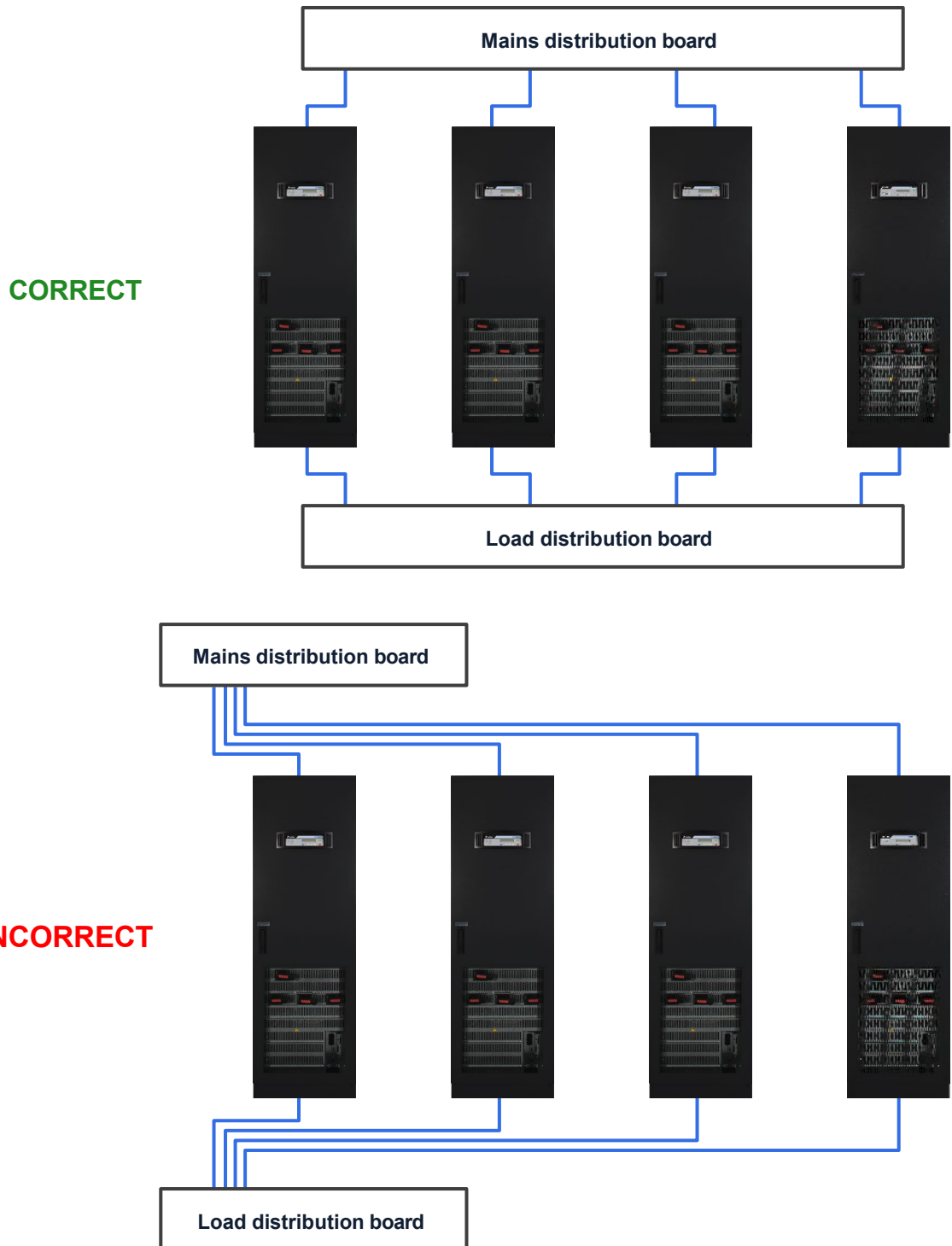

Figure 3.5 Cable lengths for multi cabinet configurations

3.3.4 External maintenance bypass switch

An external maintenance bypass is a required part of a multi-module parallel system but it is optional for a single cabinet installation.

The design and implementation of the external bypass is bespoke to the installation but generally comprises three switches rated to carry the full system load, and connected in a similar fashion to that shown in Figure 3.6.

The switches may be installed in a dedicated External Maintenance Bypass Panel or included in an existing switchgear panel. Rehiko can supply a range of external maintenance bypass solutions to suit all of its UPS systems.

When you initially start the UPS system, the start-up procedure recommends that if the load produces a large inrush current you should ideally turn on the load while the UPS is operating on the maintenance bypass before bringing the UPS inverter(s) on-line

Single UPS cabinet installation

An external maintenance bypass facility is not an essential part of a single cabinet installation as the internal maintenance bypass switch (IA1) is fully load rated for the cabinet's output.

However, in a standalone (single unit) installation it is not possible to fully power-down the UPS for test or repair when the internal maintenance bypass switch (IA1) is closed, because the UPS bypass mains supply is required to power the maintenance bypass circuit.

This situation can be overcome by adding an external maintenance bypass (MBP) facility, similar to that shown in Figure 3.6, which can supply the load through the external BYPASS switch while allowing the UPS cabinet input and output power terminals to be totally isolated by opening the external MBP INPUT and OUTPUT switches.

Parallel system installation

When two, or more, UPS cabinets are connected as a parallel system an external maintenance bypass facility is an essential part of the UPS installation.

Note that the required cable ratings for the UPS input/ bypass/output power connections are the same as those detailed earlier for the single and dual-feed installations. However the external MBP panel switches and input/output protection devices must be rated to carry the full 'system' load. This will require additional protective devices to be connected in the feed(s) to the UPS input mains (and UPS bypass mains) – e.g. to protect 'Cable A' in the example shown.

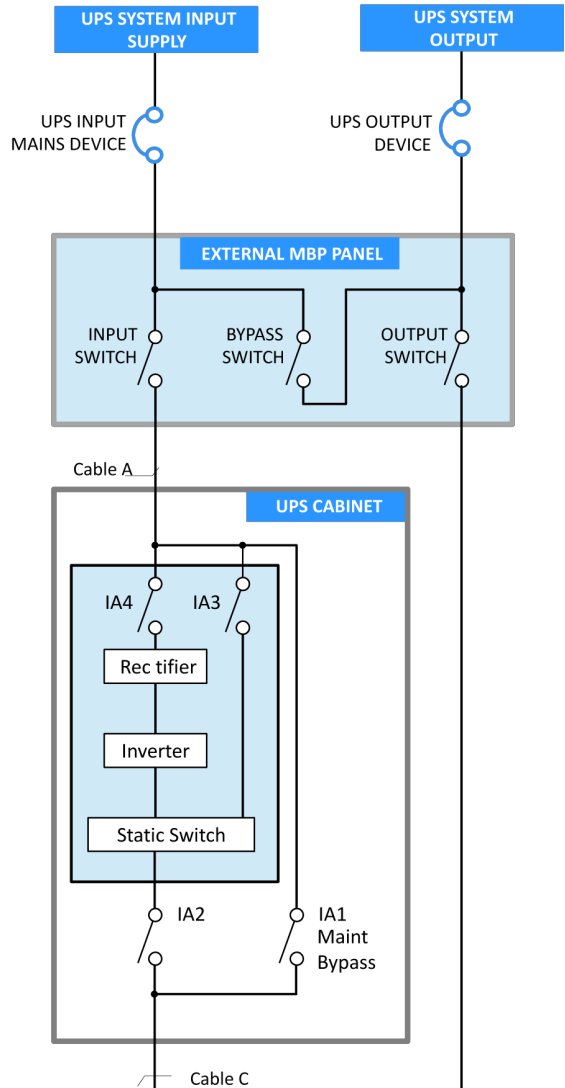

Figure 3.6 External Maintenance Bypass

4. Installation Procedure

4.1 Introduction

This chapter contains essential information concerning the unpacking, positioning, installing and cabling of the REHLKO PW 6000 (60-120 kVA) UPS.



Key Point: If you are installing an external battery cabinet supplied by Rehiko you should refer to the manual that is provided with the cabinet for installation instructions.



WARNING: All cabling operations must be supervised by an authorised electrician or other suitably qualified person. All installation procedures must be carried out in strict accordance with the instructions contained in this manual. Rehiko will take no responsibility for any personal injury or material damage caused by the incorrect installation, cabling or operation of this product.



WARNING: Once the UPS equipment is installed it must be commissioned by an engineer approved by Rehiko before it is powered-up. Rehiko will take no responsibility for any personal injury or material damage caused by the application of electrical power to this equipment before it has been fully commissioned and handed over to the customer.

4.2 Taking receipt of the UPS

The UPS cabinet and accessories are delivered on purpose designed pallets that are easy to off load and move using a forklift or suitable pallet jack.



CAUTION: Observe the following precautions when off-loading and moving the UPS:

- Always keep the packages in an upright position.
- Do not drop the equipment.
- Due to the high-energy batteries involved and heavy weight, do not stack the pallets.

Depending on the shipping method, the UPS is packed in a cardboard or wooden container designed to protect it from mechanical and environmental damage. Further protection is provided by wrapping the equipment with a plastic sheet.

Before you accept the shipment you should ensure that the received package(s) correspond to the description shown in the delivery documentation. Note that some ordered optional equipment packages might be shipped inside the UPS cabinet.

Upon receiving the UPS you should carefully examine the packing container for any sign of physical damage. External 'TiltWatch' indicators (x2) will indicate RED if the equipment has been tilted during transportation.



Figure 4.1 Tiltwatch indicators

4.2.1 Reporting transportation damage



WARNING: If the TiltWatch indicators indicate that the UPS has been tilted in transit DO NOT connect the UPS to the mains electricity supply.

If the 'TiltWatch' indicators are red or there are other signs of suspected transportation damage you must inform both the carrier and Rehiko immediately.

Claims for shipping damage must be filed immediately when found, and the carrier must be informed of ALL claims within seven days of receipt of the equipment. If the equipment is to be stored for longer than seven days before it is installed, you should unpack it and inspect it for signs of internal damage before you put it into storage. Note that some optional equipment packages might be shipped inside the UPS cabinet and these too should be inspected.

If the equipment is damaged you should store the packing materials for further investigation.

4.2.2 Local transportation

Please observe the following precautions when you transport the UPS equipment after it has been off-loaded.



CAUTION: Local transportation:

- When moving the UPS cabinet using a forklift or pallet jack, insert the lifting equipment forks into the front and rear shipping brackets to lift the cabinet securely and prevent it from toppling over.
- Do not at any time tilt the cabinet by more than 10° from vertical as it could cause internal damage.



WARNING: Potential dangers:

- If tilting occurs at any stage do not connect the UPS to the mains electrical supply.
- The cabinet weight can cause serious personal injury and/or structural damage to the surrounding area if it is dropped in transit. Always take extreme care when moving the equipment.

4.2.3 Storage

UPS Cabinet

If you plan to store the UPS cabinet prior to use it should be held in a clean, dry environment with a temperature between -25°C to +70°C and RH <95% (non condensing). An ideal storage temperature between is +20°C to +25°C.

The UPS should be stored in its original packing and shipping carton. If the packing container is removed you must take measures to protect the UPS from the ingress of dust and moisture.

Battery

The UPS uses sealed, maintenance-free batteries whose storage capacity depends on the ambient temperature. It is important not to store the batteries for longer than 6 months at 20°C, 3 months at 30°C, or 2 months at 35°C storage temperature without fully recharging them.

For longer term storage the batteries should be fully recharged every 6 months @20°C.



CAUTION: Sealed batteries must never be stored in a fully or partially discharged state. Extreme temperature, under-charge, overcharge or over-discharge will destroy batteries!

- Charge the battery both before and after storing.
- Always store the batteries in a dry, clean, cool environment in their original packaging.
- If the packaging is removed protect the batteries from dust and humidity.

4.3 Unpacking

Removing the standard UPS packaging (see Figure 4.2)

1. Remove the plastic sheet covering the UPS, by cutting it on a corner where there is a cardboard fillet underneath (A).
2. Carefully remove the 4 cardboard corner edge protectors (B) while taking care that the accessory package (C) placed on top of the UPS does not fall off.
3. Carefully retrieve the accessories package (C) – which should contain a user manual, 2 painted kick-plates (with screws), 4 feet and a set of door keys.
4. Remove the bubble wrap and securing tape (D).
5. Remove the front and back fixing bars (E) by unscrewing 8x M8 hexagonal screws (F).
6. Mount the 4x adjustable feet (G) (from the accessories package) and secure using 4x M8 tensilock nuts (H).
7. Place the UPS in its final position, then disassemble the left and right securing brackets (I) by removing the 8x M8 screws (J).
8. Fit the kick-plates (K) (from the accessories package) to the lower front and back of the cabinet and secure in place using the screws provided (L).

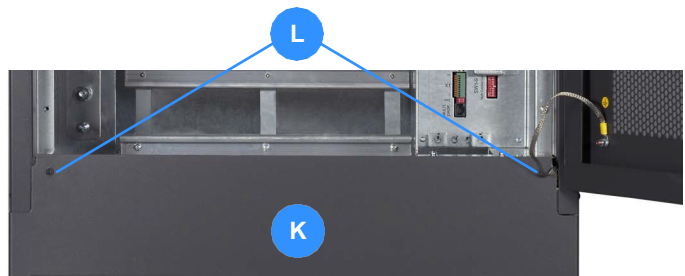
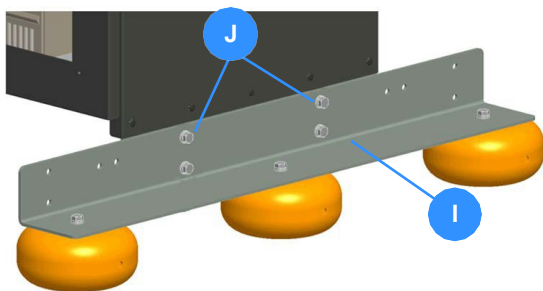
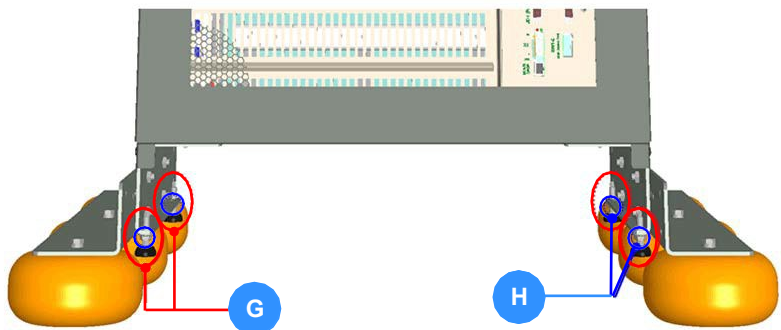

Figure 4.2 Unpacking the UPS cabinet (standard packaging)

Removing the sea freight UPS packaging (see Figure 4.3)

1. Carefully disassemble the wooden box (A) by removing all screws.
2. Remove the plastic film and bag (B) from the UPS, by cutting it away without damaging the cabinet.
3. *Note: the edges are not protected by a cardboard fillet as in the standard packaging.*
4. Remove the accessories package – which should contain a user manual, 2 painted kick-plates (with screws), 4 feet and a set of door keys – from its shipping location beneath the cabinet.
5. Using the keys from the accessories package, open the door of the UPS then remove the humidity absorbent strip inside the front of the cabinet (D) by tearing it away.
6. Similarly, remove the humidity absorbent strip from the back of the UPS cabinet.
7. Following steps 6 to 8 in the previous procedure (*Removing the standard UPS packaging*), fit the UPS adjustable feet and front/rear kick-plates.



Figure 4.3 Unpacking the UPS cabinet (sea freight packaging)

4.4 UPS Cabling procedure

4.4.1 Power cable terminations

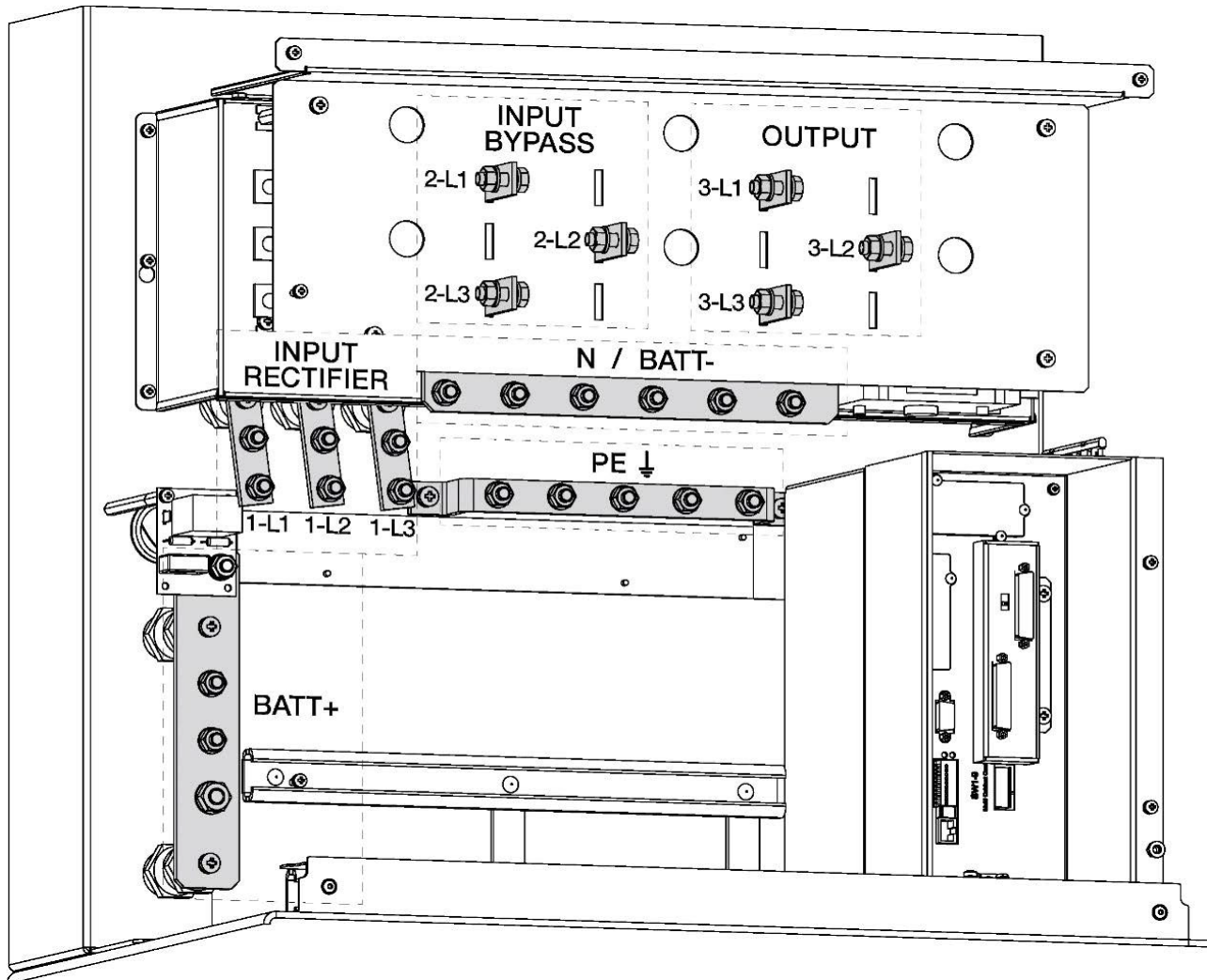

Figure 4.4 UPS Power terminal connections

All the UPS power cables enter the UPS through the bottom of the cabinet and then bolted to terminal busbars, as illustrated in Figure 4.4. The bypass/output power terminal identifications are etched on a transparent safety panel that is fitted over the front of the connections.

The table below details the maximum size of the cable terminations and the correct torque that should be applied to the termination bolts.

	Input Rectifier	Bypass Input	UPS Output	Neutral Battery -ve	Battery +ve	Earth
Terminal Identification	1-L1, 1-L2, 1-L3	2-L1, 2-L2, 2-L3	3-L1, 3-L2, 3-L3	N / BATT	BATT+	PE
Termination size	2x M8	1x M8	1x M8	5x M8	2x M8, 1x M10	5x M8
Tightening torque	22 Nm (M8), 44 Nm (M10)					

Single-feed configuration links

When the UPS is configured for a single-feed input (standard), links are fitted between the input mains supply terminals the bypass mains supply terminals (2-L1, 2-L2, 2-L3), as shown in Figure 4.5.

The 3-phase input mains supply cables are then connected to the vacant busbar connections on (1-L1, 1-L2, 1-L3) together with neutral (N) and earth (PE) busbars.

The single-feed links are fitted at the factory and must be removed on site if the UPS is to be used with a dual-input supply.

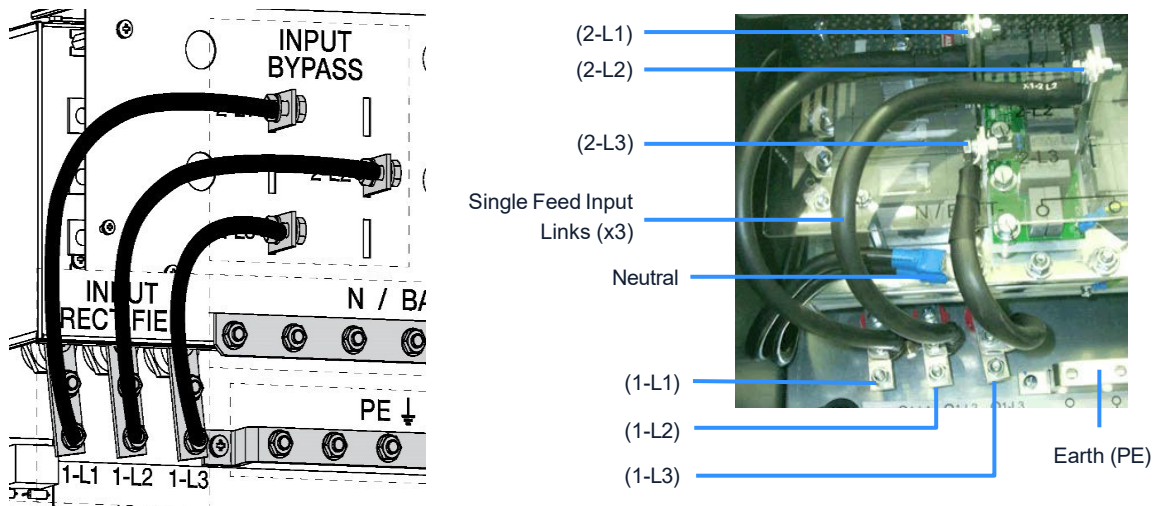

Figure 4.5 Single-feed links

4.4.2 Safety notes

Please ensure you read and understand the following safety notes before you begin the UPS electrical installation.

1. Do not commence this procedure until the UPS mechanical installation is completed.
2. All the cable installation procedures detailed below must be supervised by a qualified electrician.
3. Do not connect power cables to the UPS if there is water or moisture present.
4. Before you work on the UPS power cables or terminals, you must ensure that the UPS input/bypass mains and UPS power output supplies are isolated and 'locked-out' at their respective distribution boards. Warning notices should be posted to prevent any inadvertent operation of the UPS external supply isolators.
5. Before you connect the UPS power cables ensure that the fuses and cables provided by the customer are suitably rated in accordance with the prescribed IEC standards or local regulations – for example BS7671.
6. Once the electrical installation is completed the UPS must be commissioned by an engineer authorised by Rehlko before it is powered up and brought into use.
7. If an external Maintenance Bypass facility is used you should familiarise yourself with its operation and input/output power connections as these determine the source/destination of the UPS input and output power cables.



WARNING: Do not apply electrical power to the UPS before the commissioning visit.

8. When installing the UPS cables ensure that the connection procedures are performed under the following conditions:
 - a. No mains voltage is present at the UPS mains/bypass distribution board terminals.
 - b. All loads are shut down and isolated at the UPS output load distribution board.
 - c. The UPS is fully shut down and voltage-free.

- d. If fitted, the UPS Maintenance Bypass Isolator (IA1) is open (OFF).
- e. The UPS Parallel Isolator IA2 is open (OFF).

4.4.3 Connecting the UPS Input mains cables

1. Gain internal access to the UPS:
 - a. Unlock and open the UPS door.
 - b. Remove the lower cover plates to expose the power connection busbars.
 - c. Remove the perspex safety covers from in front of the power connections to gain full access.
Note: The connection terminals are identified on the perspex cover
2. Connect the earth cable from the mains distribution board to the UPS protective earth (PE) busbar – see Figure 4.5.

Single Input Feed

3. Ensure the single-feed links are connected between the input supply terminals and bypass input terminals (1-L1 to 2-L1, 1-L2 to 2-L2 and 1-L3 to 2-L3) – see Figure 4.5.
4. Connect the UPS input supply cables to terminals 1-L1, 1-L2, 1-L3. Ensure correct (clockwise) phase rotation.
5. Connect the input neutral to the Neutral busbar.



CAUTION: The input Neutral cable must be unswitched and grounded.

Dual Input Feed

6. Remove the single-feed links if fitted – see Figure 4.5.
7. Connect the UPS input mains supply cables to terminals 1-L1, 1-L2, 1-L3. Ensure correct (clockwise) phase rotation.
8. Connect the input neutral to the Neutral busbar.



CAUTION: The input Neutral cable must be unswitched and grounded.

9. If the bypass mains supply is obtained from a different mains distribution board to the input mains supply, connect an earth cable from the bypass mains distribution board to the protective earth (PE) busbar – see Figure 4.4.
10. Connect the UPS bypass supply cables to terminals 2-L1, 2-L2, 2-L3. Ensure correct (clockwise) phase rotation.
11. Connect the bypass neutral to the Neutral busbar.



CAUTION: If the input mains and bypass mains supplies are obtained from the same 3-phase power source it is not necessary to connect a separate bypass mains supply neutral. Avoid the connection of two separately derived neutrals in the distribution.

Note: The UPS commissioning engineer will re-configure the UPS electronics to operate with a dual feed input at the time of commissioning.

4.4.4 Connecting the UPS output cables

We recommend that a dedicated load distribution board is connected between the UPS output and the load. Before you begin connecting the UPS output cables to the load distribution board:

- Verify that the projected load does not exceed the UPS output power rating (OUTPUT POWER on the nameplate).
- Ensure the load circuit breakers on the load distribution board are correctly sized with respect to the individual load rating and associated cabling.
- Ensure that the maximum total load rating, and the maximum load rating of each individual load socket, is indicated on the load distribution board.

The circuit breakers must comply with the prescribed IEC Standards – e.g. BS7671.

1. Connect the earth cable from the load distribution board to the UPS protective earth (PE) busbar – see Figure 4.4.
2. Connect the UPS 3-phase output cables between terminals 3-L1, 3-L2, 3-L3 and the appropriate connections at the load distribution board. Ensure correct (clockwise) phase rotation.
3. Connect the UPS output neutral cable between terminal 3-N and the neutral connection in the load distribution panel.



CAUTION: *The output Neutral cable must ALWAYS be connected.*

4. Check that the output cables are connected to the correct power terminals on the load distribution board.

4.4.5 Connecting the battery

IMPORTANT NOTE

The batteries must be installed and connected to the UPS by the Rehko commissioning engineer. High voltage battery strings can be extremely dangerous and **should not** be installed by the customer's installation team.

It is the customer's responsibility to install appropriate cable containment facilities between the UPS cabinet and battery cabinet where necessary – e.g. cable trays or trunking. Contact Rehko for further installation advice if required.

4.5 Remote monitoring and control facilities

4.5.1 Module communications interface

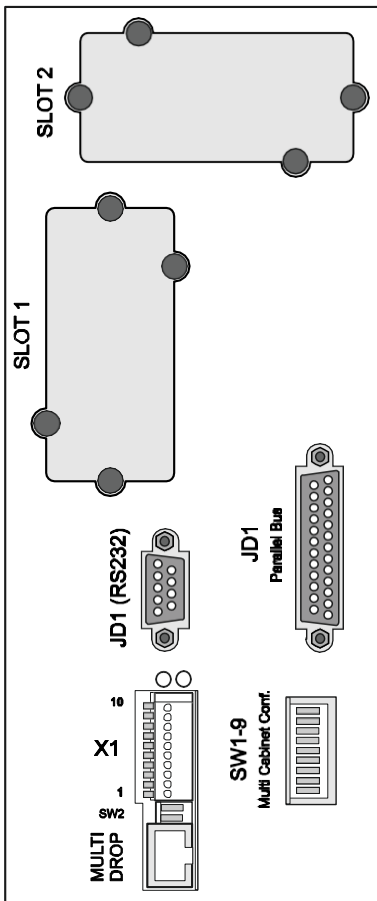

SLOT 1 – Can be used for optional USB and Relay Card (customer outputs).

SLOT 2 – Can be used for optional SNMP card.

JD1 (RS232) – Can be used for serial communications with laptop or PC.

Status LEDs – (Just above X1) indicate the interface board operating status.

X1 Customer Inputs – external status/control inputs to interface board.

SW2 – Multidrop configuration switches (service engineer use only).

Multidrop Connector – RJ45 connector linked to adjacent parallel cabinet. Service engineers use only (see Key Point above).

JD1 Parallel Bus – Hosts adapter card in a parallel system that is used to connect the inter-cabinet parallel control bus cables. Service engineers use only (see Key Point above).

SW1-9 – Parallel configuration DIP switch (service engineer use only).

Figure 4.6 UPS Communications interface board connectors

Various remote monitoring and control facilities can be connected to the communications interface board located in the front, lower right-hand corner of the UPS module. The external cables enter the cabinet through the cabinet floor in the same manner as the power cables.

Although all connected features will be checked by the commissioning engineer when the UPS system is commissioned, they can be connected by the customer installation team at this point provided no external power is applied to the circuits until they have been properly commissioned. Details of the interface facilities and other options are provided in Chapter 8.



Key Point: In a parallel system UPS cabinet a 'parallel adapter' board is fitted to the [JD1 Parallel Bus] connector which is in turn connected to the parallel control bus cables that pass between every module. Similarly an inter-module cable is connected to the Multidrop RJ45 connectors.

These cables must be installed and configured by the commissioning engineer; however, depending on the position of the cabinets, it may be necessary for the customer to provide any necessary cable containment. Contact Rehiko for further installation advice if required.

5. Operating Instructions

5.1 Introduction

The REHLKO PW 6000 (60-120 kVA) UPS system must be commissioned by a fully trained engineer authorised by Rehiko before it is put into use.

The commissioning engineer will:

- check the UPS electrical and mechanical installation, and operating environment
- install and connect the UPS batteries
- check and complete the UPS configuration settings
- check the installation and operation of any optional equipment
- perform a controlled UPS start-up
- fully test the system for correct operation
- provide customer training and hand over the system in a fully working condition with all the UPS modules turned on and operating in the 'on inverter' mode (or 'on bypass' mode, if appropriate)



WARNING: Rehiko will not accept responsibility for the equipment or the safety of any personnel if the UPS system is operated before it has been fully commissioned.

The manufacturer's warranty will be invalidated if power is applied to any part of the UPS system before it has been fully commissioned and handed over to the customer.

5.1.1 Operating procedure summary

Under normal circumstances all the UPS modules in a multi-module system are turned on and operating in their 'on inverter' mode. If one module is turned off, or fails, in a 'redundant module' system the faulty module shuts down but it will

not affect the remaining module(s), which will continue to operate normally and provide protected load power¹. If necessary, the inoperative module can be serviced or tested off-line by a trained service engineer without affecting the operation of the remainder of the UPS system.

If a UPS module fails in a 'capacity' rated (or standalone) system, the load will immediately transfer to the static bypass and thereby connected to the unprotected bypass mains power supply.

A parallel-module PW 6000 (60-120 kVA) UPS installation requires an external maintenance bypass facility which wraps around the entire UPS system – this is optional in a standalone UPS cabinet installation. The external maintenance bypass is bespoke to the installation and can be installed in a separate cabinet or switchgear panel (*see page 25*). If an external maintenance bypass is installed you should familiarise yourself with its operation before using the UPS operating procedures contained in this chapter.

Note: All the switches and control panel operations mentioned in this chapter are identified and described in Chapter 2.

This chapter contains the following procedures:

- How to start the UPS system from a fully powered-down condition - see paragraph 5.2
- How to start the UPS system from the maintenance bypass - see paragraph 5.3
- How to transfer the load to the maintenance bypass - see paragraph 5.4
- How to shut down the complete UPS system - see paragraph 5.5
- Operating in ECO ('on bypass') mode - see paragraph 5.6
- Individual module stop/start procedure (redundant parallel system) - see paragraph 5.7

1. In a redundant module UPS system certain module fault conditions could potentially transfer the load to bypass.

5.1.2 General warnings



WARNING: The procedures given below must be performed by a trained operator.



WARNING: When the UPS system is operating on BYPASS or via the MAINTENANCE BYPASS SWITCH, the load supply is unprotected if the bypass mains supply fails. It is essential that the load user is informed of this possibility before you intentionally select these operating modes.



WARNING: When the UPS is shut down, power is still applied to the UPS input/bypass terminals unless the mains supplies are isolated at the incoming switchgear panel. In a standalone cabinet installation it is not permissible to turn off the external input/bypass mains supply if the load is intentionally connected via the internal maintenance bypass switch (IA1) as this will also disconnect the load power.

5.2 How to start the UPS system from a fully powered-down condition

IMPORTANT NOTE

In the following procedures all references to the 'Maintenance Bypass Switch' apply to the internal maintenance bypass switch (IA1) a standalone UPS cabinet if it is not connected to an external maintenance bypass facility.

If an external maintenance bypass facility is installed (standard in a parallel-cabinet system) all references to the 'Maintenance Bypass Switch' apply to the maintenance bypass switch located in the external facility.



Key Point: In order to reduce the possible effects of high inrush currents that might occur when the load is initially turned on, we recommend that you power-up the load when the UPS system is operating on the maintenance bypass before transferring it to the UPS inverter(s), as described in this procedure.



CAUTION: You should familiarise yourself with the operation of the external maintenance bypass circuit operation before using this procedure.

Initial conditions:

This procedure assumes the following initial conditions (for each module in a parallel system):

- The UPS maintenance bypass switch is open.
- The external UPS system output isolator on the load distribution panel is open.
- The UPS input/bypass supply fuses or (breakers) are open (OFF) at the incoming mains distribution board.
- The UPS module power switches (IA2) (IA3) and IA4) are open (OFF).
- The battery fuses (breakers) fitted in the battery cabinets/racks are open (OFF).

Power-up the load:

1. Turn ON the UPS system input/bypass mains supply (for ALL modules).
 - a. Power is now applied to the UPS module(s), but it is turned OFF.
2. On the module control panel (of ALL modules) verify that:
 - a. The LINE 1 LED is green.
 - b. The BATTERY LED is flashing red.
 - c. All other mimic LEDs are OFF
 - d. The LCD displays LOADOFF, SUPPLYFAILURE.
 - e. If necessary press the RESET button to obtain this display.
3. Close the external UPS system output isolation device on the load distribution panel.
4. Close the UPS maintenance bypass switch (see the "IMPORTANT NOTE" above).

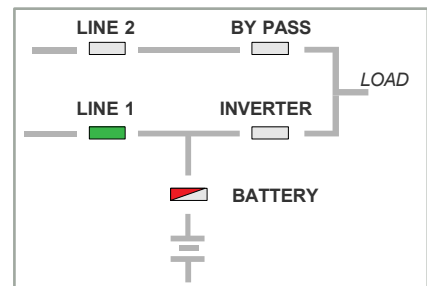

5. Turn on the load equipment.
 - a. The load is now powered through the maintenance bypass.
 - b. The module control panel mimic indications do not change.
 - c. The event log shows MANUAL BYP IS CLOSED.
6. Press the RESET button.
 - a. The LCD displays LOADOFF, SUPPLYFAILURE.

Start the UPS modules

7. Carry out steps 8 to 13 below (for every module in a parallel module system).
8. On the UPS module close the input switch (IA3) and bypass switch (IA4).
9. Close the UPS parallel isolator switch (IA2).
10. On the module control panel, simultaneously press both ON/OFF buttons.
 - a. The UPS module will begin to power up over approximately 60s.
11. On the module control panel, after 60s verify that:
 - a. The LINE 1 LED is green.
 - b. The LINE 2 LED changes to green.
 - c. The BYPASS LED is green.
 - d. The INVERTER LED is red.
 - e. The BATTERY LED is flashing red.
 - f. The LCD displays LOADNOTPROTECTED.
12. Close the external battery fuse / circuit breaker.
 - a. The BATTERY LED should change to a flashing green then to a solid green within 5 minutes.
13. On the module control panel verify that:
 - a. The LCD displays PARALLEL SW CLOSED.
14. Before you continue, ensure that the indications on the module control panels of ALL modules in a parallel-module system are identical and as described above.

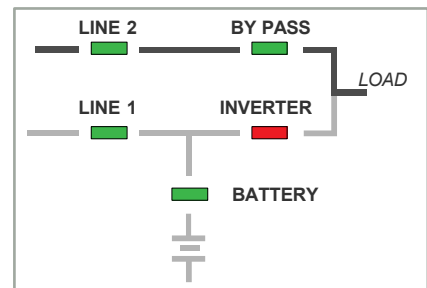
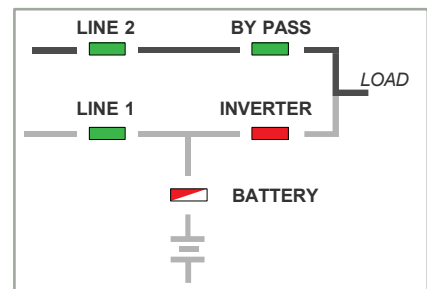

Transfer the load to inverter:

15. Only proceed if the module control panel BYPASS LED is green (on ALL modules).

Note: If the BYPASS LED is not green, repeat step 7 then seek trained advice if it still fails to light green.

16. Open the maintenance bypass switch (see "IMPORTANT NOTE," on page 36).
 - a. The module control panel LCD should display MANUAL BYPASS OPEN followed by LOAD NOT PROTECTED.
 - b. The (red) INVERTERled will extinguish.
 - c. The module control panel mimic indications should be as shown here.
17. The load is now being powered through the UPS static bypass.
 - a. Check the UPS input and output metered parameters to ensure that they are correct.
 - b. Note any active alarms and take appropriate actions if an alarm cannot be reset.

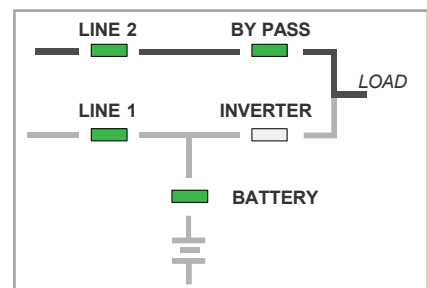

18. On the module control panel:
 - a. Press the UP key once to access the menu system.
 - b. Use the UP / DOWN keys to move the cursor so that it is adjacent to COMMANDS and then press the ENTER key.
 - c. Use the UP / DOWN keys to move the cursor so that it is adjacent to LOAD TO INVERTER and then press the ENTER key.
19. The UPS module output should transfer to inverter.
20. On the module control panel (of ALL modules) verify that:
 - a. The BYPASS LED is extinguished.
 - b. The INVERTER LED changes to green.

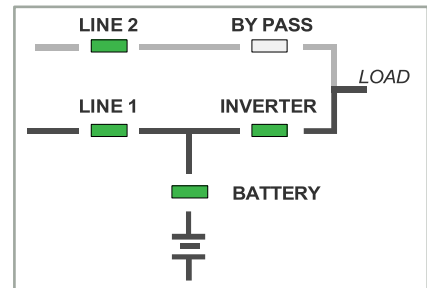

Key Point: The UPS System is now in its 'on inverter' operating mode and providing the load with processed, protected power.

5.3 How to start the UPS system from the maintenance bypass

Initial conditions:

This procedure assumes the following initial conditions.

- The UPS input and bypass mains supplies are turned ON at the switchgear panel.
- The load equipment is turned on and receiving power through the UPS maintenance bypass.



Key Point: If the load is not already turned on, turn it on now, while the UPS system is operating on maintenance bypass, before you continue with this procedure.

Powering up the UPS system:

If the UPS system is operating on maintenance bypass it can be powered up using the procedure described in paragraph 5.2 ("How to start the UPS system from a fully powered-down condition") beginning at step 7.

5.4 How to transfer the load to the maintenance bypass

It may be necessary to transfer the load to the maintenance bypass supply to perform certain service or maintenance operations – for example, when repairing a module in a standalone or capacity parallel module system.

This procedure is normally carried out by a trained service engineer and is not usually part of the day-to-day management of the UPS system.



CAUTION: Before you carry out this procedure, warn the critical load user that the load will not be supplied with processed, backed-up power once the transfer to maintenance bypass has been performed.

Initial conditions:

This procedure assumes one of the following initial conditions.

1. The UPS system is operating normally, 'on inverter' In which case continue with step 3 below:

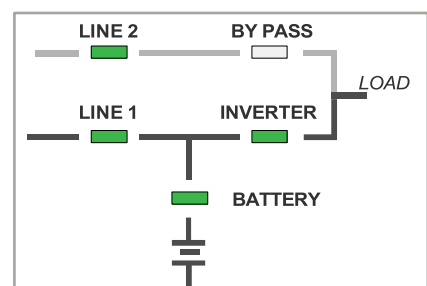

2. The UPS system is operating with the load 'on bypass' due to either
 - a system fault
 - severe overload
 - loss of redundancy
 - or operating in 'ECO' mode

In which case continue with step 7 below:

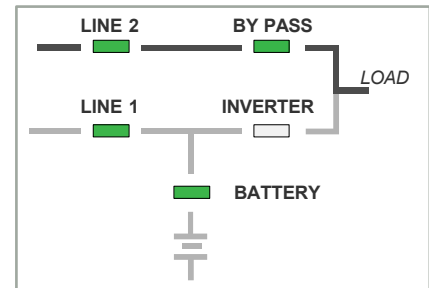

Transfer the load to the UPS static bypass:

3. On the UPS control panel (on any module in a parallel-module system) press the ENTER key once to access the menu system.
4. Using the UP/DOWN keys, move the cursor so that it is adjacent to COMMANDS and then press the ENTER key.
5. Using the UP/DOWN keys, move the cursor so that it is adjacent to LOAD TO BYPASS and then press the ENTER key.
 - a. The UPS system will transfer the load to static bypass (on all UPS modules in a parallel-module system).
6. On the module control panel(s), verify that:
 - a. The INVERTER LED has extinguished.
 - b. The BYPASS LED is green.
 - c. The LCD displays LOAD NOT PROTECTED.

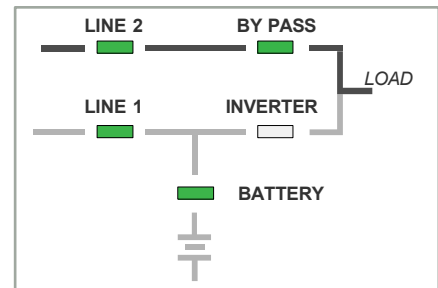

Transfer the load to maintenance bypass:

7. Close the maintenance bypass switch (see "IMPORTANT NOTE," on page 36).
8. On the module control panel(s), verify that:
 - a. The INVERTER LED is red.
 - b. The BYPASS LED is green.
 - c. The module control panel will display MANUAL BYP IS CLOSED.
9. Press the RESET button (on all UPS modules) to cancel the audible alarm.

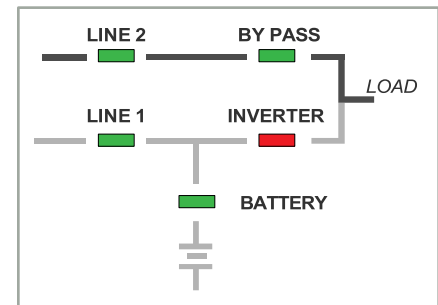

Turn off the UPS module:

10. Carry out steps 11 to 13 on each UPS module in turn.
11. On the module control panel, simultaneously press both ON/OFF buttons and verify that:
 - a. All LEDs turn OFF except for LINE 1 and BATTERY (flashing green).
12. Open the module's parallel isolator (IA2).
13. Open the external battery fuse(s).
 - a. The BATTERY LED will flash red.

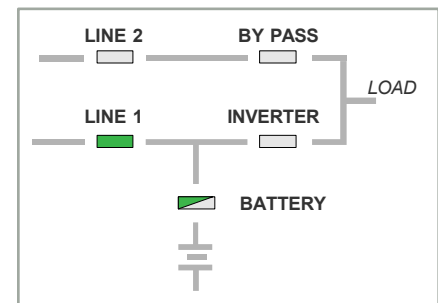



Key Point: The UPS System (single or multi-module) is operating on maintenance bypass, and the load is unprotected.



WARNING: In a standalone (single unit) installation using the internal maintenance bypass switch (IA1), the UPS bypass mains supply must be maintained in order to provide power at the UPS output terminals.

DO NOT OPEN THE BYPASS MAINS SUPPLY FUSES/ CIRCUIT BREAKER.

If an external maintenance bypass facility is used, the UPS modules' input/bypass supply can be turned off – see the operating instructions for the bespoke external maintenance bypass facility for details.

5.5 How to shut down the complete UPS system

The UPS system can be completely shut down if the load does not require power for an extended period of time.



CAUTION: Before you carry out this procedure, warn the critical load user that power is about to be removed.

1. If the UPS system is not already operating on maintenance bypass, transfer the load to the maintenance bypass and turn OFF the UPS module(s) as described in paragraph 5.4.
2. Turn OFF power to the load equipment by opening the load isolation devices and UPS system output isolation device on the load distribution panel.
3. Open the maintenance bypass switch.
4. Turn OFF the UPS input mains and bypass mains supplies.
5. Where used, refer to the operating instructions for the bespoke external maintenance bypass facility for additional details of how to isolate the UPS mains supply if necessary.
6. The UPS system cabinet(s) is now voltage free.

5.6 Operating in ECO ('on bypass') mode

When operating the UPS system in ECO ('on bypass') mode, the load is powered through the UPS bypass supply under normal conditions and transferred to the inverter ('on inverter' mode) automatically if the bypass supply fails.



CAUTION: There will be a very short supply break when the UPS switches to the 'on inverter' mode, so you should elect to operate the system in the ECO mode only if a load can withstand a brief supply break.

5.6.1 How to Turn ON the UPS system and operate in 'on bypass' (ECO) mode

1. Follow the standard UPS system start-up operating instructions in paragraph 5.2 but do not perform the "Transfer the load to inverter:" stage (step 15 onwards).

5.6.2 How to Turn OFF the UPS system when operating in 'on bypass' (ECO) mode

1. Follow the standard UPS system shut down operating instructions in paragraph 5.4 beginning at step 10 – as the load is already operating on bypass.

5.6.3 How to transfer between ECO ('on bypass') and 'on inverter' mode

2. The UPS can be manually switched between the 'on bypass' and 'on inverter' mode through the module control panel load transfer menu.

To transfer the UPS system from 'on inverter' to ECO ('on bypass') mode:

1. On the UPS control panel (on any module in a parallel-module system) press the ENTER key once to access the menu system.
2. Using the UP/DOWN keys, move the cursor so that it is adjacent to COMMANDS and then press the ENTER key.
3. Using the UP/DOWN keys, move the cursor so that it is adjacent to LOAD TO BYPASS and then press the ENTER key.
 - a. The UPS system will transfer the load to the static bypass (on all UPS modules in a parallel-module system).
4. On the module control panel(s), verify that:
 - a. The INVERTER LED has extinguished.
 - b. The BYPASS LED is green.
 - c. The LCD displays LOAD NOT PROTECTED.

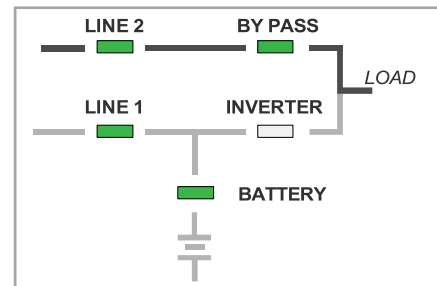

Transfer the UPS system from ECO ('on bypass') mode to 'on inverter' mode:

5. On the module control panel (on any module in a parallel system):
 - a. Press the UP key once to access the menu system.
 - b. Use the UP/DOWN keys to move the cursor so that it is adjacent to COMMANDS and then press the ENTER key.
 - c. Use the UP/DOWN keys to move the cursor so that it is adjacent to LOAD TO INVERTER and then press the ENTER key.
 - d. The UPS module output should transfer to inverter.
6. On the module control panel(s), verify that:
 - a. The BYPASS LED has extinguished.
 - b. The INVERTER LED is green.
 - c. The LCD displays LOAD PROTECTED.

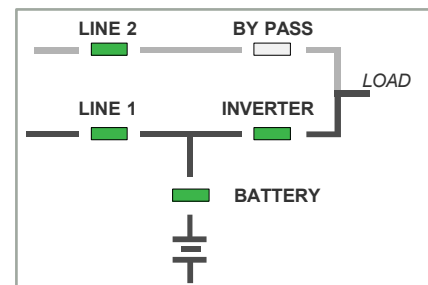

5.7 Individual module stop/start procedure (redundant parallel system)

As described earlier in this manual, if a parallel module UPS system includes module redundancy an individual UPS module can be shut down without affecting the overall system operation. The situations where this might be put into effect are usually managed by a qualified service engineer when undertaking service repairs; however, under certain circumstances there may be a case for this to be carried out by the user. For example, if a large proportion of the load is to be shut down for a significant period the number of on-line modules in the UPS system might be reduced to save on the utility power demands.



WARNING: The load will be transferred to bypass and not supported by the UPS system if:

- You turn off the module in a standalone system, or
- You turn off a module in a capacity rated system (which may overload the remaining on-line modules).

Module shutdown:

1. Turn OFF the UPS module by pressing both ON/OFF buttons simultaneously then releasing them.
 - a. The module control panel will display LOAD OFF and SUPPLY FAILURE.
 - b. The module control panel mimic indications should be as shown here.
2. Open the module's parallel switch (IA2).

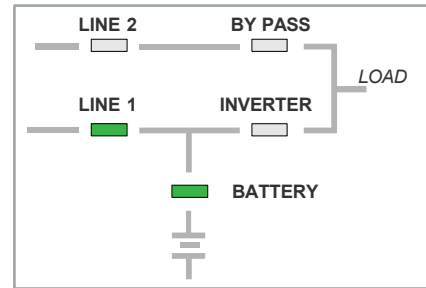

3. Open the battery fuses/breaker located in the external battery cabinet/rack.
 - a. The BATTERY led on the module mimic should change to flashing green.
 - b. The module control panel mimic indications should be as shown here.
4. Open the UPS input isolator (IA3) and bypass isolator (IA4).
 - a. The module is now fully powered down.

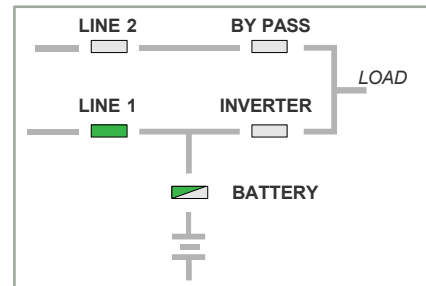

WARNING: The UPS module is still live at its input and output power terminals. Allow 10 minutes for the internal DC capacitors to discharge before touching any UPS internal components.

Module start-up:

1. Close the UPS input isolator (IA3) and bypass isolator (IA4).
2. Close the module's parallel switch (IA2).
3. Close the battery fuses/breaker located in the external battery cabinet/rack.
 - a. The module control panel will display LOAD OFF, SUPPLY FAILURE.
 - b. The BATTERY led on the module control panel mimic should change from flashing to permanent green.
 - c. The module control panel mimic indications should be as shown here.
4. Turn ON the UPS module by simultaneously pressing both ON/OFF buttons then releasing them.
 - a. The UPS module(s) will start-up over about 60 seconds.
 - b. The INVERTER will start-up and come on line (Green).
 - c. The module control panel will display LOAD PROTECTED.
 - d. The module control panel mimic indications should be as shown here.

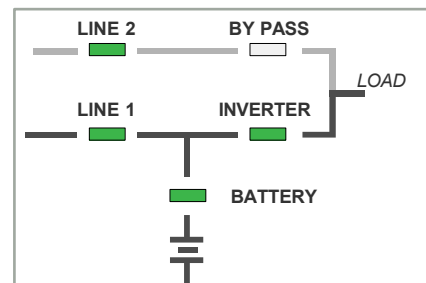
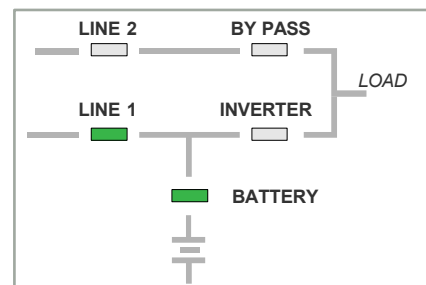

6. Maintenance

6.1 Introduction



WARNING: The procedures described in this chapter must be performed by an authorised engineer/ Rehiko approved engineer who has received the appropriate level of training on this UPS system.

The UPS maintenance requirements are minimal as there are no user-serviceable parts contained within the UPS cabinet. However, we recommend that the UPS and batteries are inspected and calibrated on a 6 monthly basis as part of a preventative maintenance schedule to maximise the system's performance, working life and reliability.

6.2 User responsibilities

The UPS equipment should be inspected daily to ensure that the environment in which it is operating is kept cool and dust free, and the operating temperature and humidity is within the equipment's specified operational range. The UPS equipment should also be maintained in accordance with the manufacturer's recommendation and any life limited components replaced at the required intervals and critical updates are performed

Any active alarm or status indication that suggests that the UPS is not functioning correctly should be dealt with immediately by referring to the troubleshooting chapter of this manual or contacting the manufacturer's service desk.

Routine maintenance



WARNING: When working inside the UPS cabinet there is a risk of exposure to potentially lethal AC and DC voltages. All work that requires internal cabinet access must be carried out by trained personnel only.

The commissioning engineer will leave a service record book inside the front of the UPS which will be used to log the future UPS service history. To ensure optimum UPS operation we recommend that the system's operating parameters are checked and logged every six months.

Preventative maintenance inspections form an integral part of all Extended Warranty Agreements (maintenance contracts) offered by Rehiko. For further details on Extended Warranty Agreements see the warranty information at the front of this manual.

A preventative maintenance inspection includes the following:

• Site/environment conditions	• Integrity of electrical installation
• Cooling airflow	• Rectifier/booster operation and calibration
• Inverter operation and calibration	• Static switch operation
• Battery status and condition	• Load characteristics
• Integrity of alarm and monitoring systems	• Correct operation of all installed options
• Condition of life limited components	• Manufacturer recommended updates

6.3 Battery testing

A battery test can be initiated from the UPS control panel and takes approximately 3 minutes to complete.

The battery test procedure, which can be carried out irrespective of the operating mode ('on inverter' or 'on bypass') and whether or not the load is connected, should be performed only if there are no existing alarm conditions and the battery is initially fully charged.

7. Troubleshooting

7.1 Alarms

A number of UPS operating parameters and conditions are monitored and will generate an alarm or warning event notification on the UPS control panel if an error is detected or an abnormal condition occurs.

In the event of an alarm occurrence you should:

1. Silence the audible warning.
2. Identify the cause of the alarm by inspecting the UPS module control panel 'event' register.
3. Interpret the cause of the alarm (see below) and seek assistance from your nearest service centre if the cause of the alarm is beyond simple rectification.

IMPORTANT NOTE

Certain alarm conditions may 'latch-on' even after the cause of the alarm is no longer present. For example, if there is a brief mains failure during unattended operation the MAINS RECT FAULT/MAINS BYP FAULT alarm will activate and it may still indicate a fault condition even after the mains supply has returned to normal. Similarly, a LOAD ON BYPASS alarm might have been caused by an inverter overload.

If any alarm appears, the first action to take is to attempt to RESET it.

If the alarm indication resets then it was probably caused by a transient condition; the UPS has responded correctly and no further action is required. Investigative action is necessary only if it is not possible to reset the alarm or if the alarm occurrence is repetitive, in which case you should seek advice or assistance from the Rehiko Service Department.

7.2 LCD Control panel

The LCD Control panel is described on page 12.

If an alarm condition occurs, the red ALARM led will flash accompanied by an audible warning:

1. Cancel the audible warning by pressing the RESET button.
 - a. If the alarmed condition was transient the audible warning will stop and the red warning light will extinguish.
 - b. If the red warning remains ON it indicates that the cause of the alarm is still present and must be investigated.
2. Investigate the cause of the alarm by making a note of the EVENT LOG, which is accessed from the MAIN MENU – this will present a list of time-stamped events that took place preceding the detected alarm. The module control panel menu map is shown in Figure 2.10 on page 15.
3. Access the MEASUREMENTS screen from the MAIN MENU and make a note of the UPS input, output, battery parameters etc.
4. Refer to the following troubleshooting table for possible fault resolutions.

7.3 Troubleshooting table

ALARM CONDITION	MEANING	SUGGESTED SOLUTION
MAINS RECT. FAULT	Input mains power supply is outside prescribed tolerance.	The UPS input mains voltage to UPS is low or missing. If site power appears to be OK, check the UPS input mains supply fuses /circuit breakers etc.
MAINS BYP. FAULT	Bypass mains power supply is outside prescribed tolerance.	The UPS bypass mains voltage to UPS is low or missing. If site power appears to be OK, check the UPS input mains supply fuses /circuit breakers etc.
OUTPUT SHORT	There is a short circuit at the output of UPS (on the load side).	Check for a short circuit on a connected load. Check all output connections and protective devices.
OVERLOAD	Load exceeds the UPS rated power.	Identify which piece of equipment is causing the overload and disconnect it from the UPS
TEMPERATURE HIGH	UPS temperature has exceeded the allowed value.	Check the ambient temperature of the UPS is <40°C. If the ambient temperature is normal call the authorised service centre for assistance.
INV. PHASE FAULT	Inverter is faulty.	Call the authorised service centre for assistance.
SYNCHRON. FAULT	The inverter and mains are not synchronised.	The frequency of the UPS input mains supply is outside the configured UPS operating limits and the UPS static bypass has been temporarily disabled. Call the authorised service centre for assistance if this is a repetitive problem
BATTERY IN DISCHARGE	Battery is near end of autonomy	Shutdown the load connected to UPS before the UPS switches itself off to protect its batteries
MANUAL BYP IS CLOSED	Maintenance bypass closed. Load supplied by mains	This alarm is only displayed if the UPS is on maintenance bypass. If this is not a desired state, turn on the UPS system following the correct operating procedure.

7.4 Contacting service

Rehiko has a service department dedicated to providing routine maintenance and emergency service cover for your UPS. If you have any queries regarding your UPS please contact us.

UK

www.ups.rehiko.co.uk

ukservice.ups@rehiko.com

uktechnicalsupport.ups@rehiko.com

uksales.ups@rehiko.com

ukservicesales.ups@rehiko.com

Rehiko web site

Service department – booking service, fault reporting etc.

Technical queries

Hardware sales

Extended warranty agreements etc

IRELAND

www.ups.rehiko.ie

ieinfo.ups@rehiko.com

Rehiko web site

Service department, technical queries, hardware sales and extended warranty agreements

SINGAPORE

www.ups.rehiko.sg

salesups.sg@rehiko.com

serviceups.sg@rehiko.com

Rehiko web site

Hardware sales

Contract customer support, maintenance contracts renewals

8. Options

8.1 Introduction

A communications interface board is fitted to the bottom front right-hand corner of each UPS cabinet. The interface board, shown in Figure 8.1, enables various external monitoring and control applications to be connected to the UPS system to satisfy most local and remote control and monitoring requirements.

Two LEDs (4) are located on the communications interface board to indicate its operating status:

- The green led indicates the UPS cabinet's master/slave status in a parallel module system.
- flashing twice/sec = interface is master (1st cabinet).
- flashing once/sec = Interface is slave (2nd,.. 10th cabinet).
- The red led signifies a board malfunction and possibly needs replacing.

1	SLOT 2 – for optional USB and Relay card. Relay card provides UPS/MAINS status via volt-free relay switching. USB provides an alternative RS232 output to communicate with remote computer. (see paragraph 8.3)
2	SLOT 1 – for optional SNMP card. (see paragraph 8.6)
3	JD1 – RS232 Communications for computer interface. (see paragraph 8.3)
4	Communications interface board operations status leds
5	X1 – Customer control inputs (see paragraph 8.2)
6	SW2 – Multidrop configuration DIP switch
7	MULTIDROP – JR45 multidrop cable connection (see paragraph 8.5)

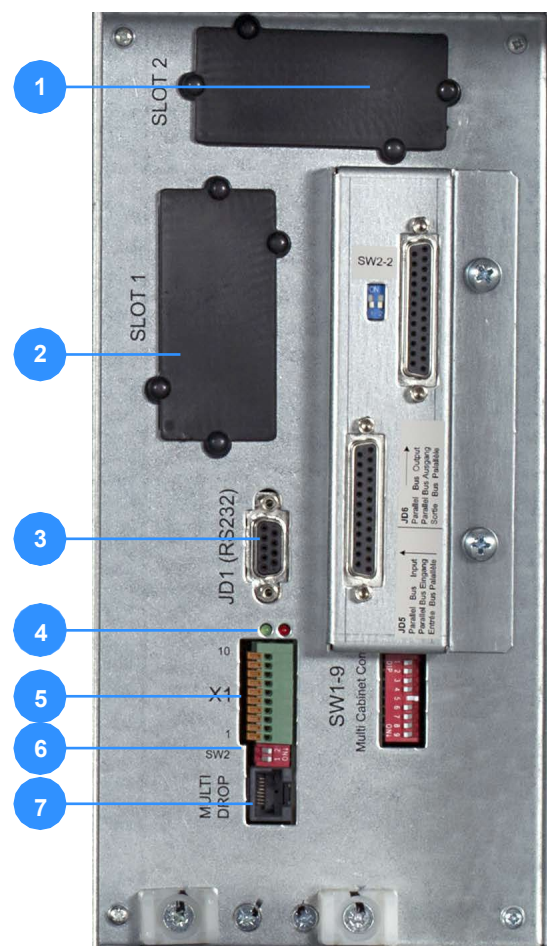
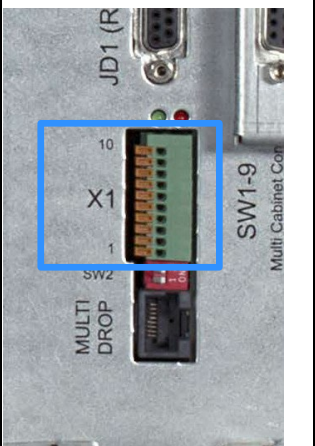

Figure 8.1 UPS Communications interface board connectors

8.2 Customer control inputs (X1)

Terminal block X1 provides a range of standard input interfaces that can be used by the customer as required. All connections are made to Phoenix spring terminals using wires up to 1.5 mm².

	Terminal	Contact	Signal	Function	
X1	X1/10	Gnd	Gnd	+12Vdc Power source (max 200mA)	
	X1/9	In	+12Vdc		
	X1/8	Gnd	Gnd	REMOTE SHUTDOWN (Emergency Power Off) (Do not remove the factory-fitted bridge if this feature is not used)	
	X1/7	In	+12Vdc		
	X1/6	Gnd	Gnd	BATTERY TEMPERATURE SENSING (If connected this input is battery temperature dependent)	
	X1/5	In	+3.3V		
	X1/4	Gnd	Gnd	CUSTOMER SPECIFIC INPUT (Function on request to be defined)	
	X1/3	In	+12Vdc		
	X1/2	Gnd	Gnd	GENERATOR OPERATION (NC = Generator on line)	
	X1/1	In	+12Vdc		

8.2.1 Remote shutdown

The remote shutdown facility comprises a normally-closed switch connected between terminal X1/7 and X1/8 (see Figure 8.2).

When the remote switch is opened it turns OFF the UPS output which removes the load supply.

It is recommended that a terminal block, with linking facilities, is installed between the UPS and the remote shutdown switch, as shown, in order to allow the removal, maintenance or testing of the remote circuit without affecting the UPS operation.

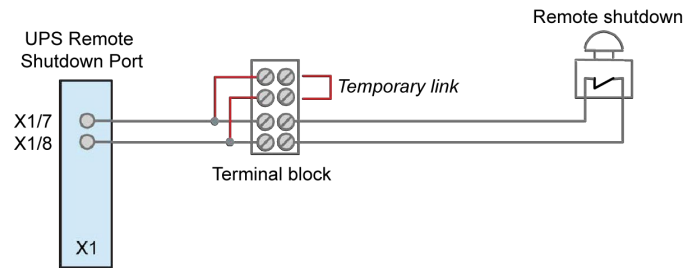

Figure 8.2 Remote emergency stop cabling

On a standard UPS module the remote shutdown (EPO) function is disabled by a bridging link fitted between X1/7-X1/8.

If the remote shutdown option is required, it must be activated by a hardware code on the SETUP SERVICE menu and the link removed. This will be done as part of the system commissioning process. If you wish to activate this feature after the system has been commissioned please contact Rehiko service department for advice.

1. Use a screened cable with 1 pair (section of wires 0.5 mm² - 1.5 mm²) and maximum length of 100m.
2. Connect the cable as shown in Figure 8.2.



WARNING: The remote shutdown function only serves to disconnect the output supply from the UPS to the load and it does not totally shut down the UPS. If you want the remote shutdown facility to totally shut down the UPS system you must install a contactor in the UPS input/bypass mains supply that is also controlled from the remote shutdown function.

8.2.2 Generator ON facilities

The generator ON facility must use a normally-open contact which closes when the standby generator is running and providing the UPS input power source.

When this option is used, it can be configured to inhibit the operation of the battery charger and/or static bypass while the generator is on-line.

3. Use a screened cable with 1 pair (section of wires 0.6 mm²) and maximum length of 100 m.
4. Connect the cable as shown in Figure 8.3.

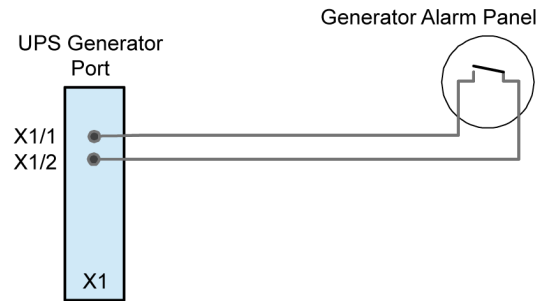
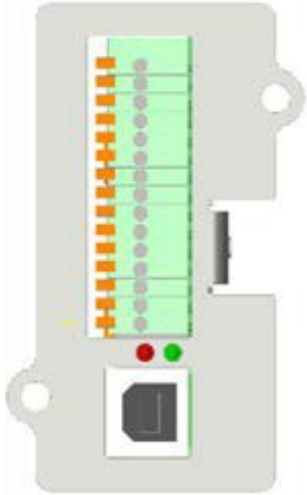

Figure 8.3 Generator ON Connection

8.3 Customer outputs (+USB)

The customer output interfaces are on an optional relay card that can be installed in Slot 2 on the communications interface board. The relay card contains 5 relay-switched, volt-free outputs that can be connected to the external site monitoring/ BMS facilities. The relays are rated at 60VAC and 500mA and the connections are made to Phoenix spring terminals using wires of up to 1.5mm².

	Terminal	Contact	Signal	Display	Function
X1	X2/15	Com	ALARM	COMMON_ALARM	Common
	X2/14	N/C			No Alarm Condition
	X2/13	N/O			Common Alarm (system)
	X2/12	Com	MESSAGE	LOAD_ON_MAINS	Common
	X2/11	N/C			Load On Inverter
	X2/10	N/O			Load On Bypass (mains)
	X2/9	Com	ALARM	BATT_LOW	Common
	X2/8	N/C			Battery OK
	X2/7	N/O			Battery Low
	X2/6	Com	MESSAGE	LOAD_ON_INV	Common
	X2/5	N/C			Load On Bypass (mains)
	X2/4	N/O			Load On Inverter
	X2/3	Com	ALARM	MAINS_OK	Common
	X2/2	N/C			Mains Not Present
	X2/1	N/O			Mains Present



8.4 Serial RS232 Computer interface – USB & JD1 (Smart Port)

A serial RS 232 interface is available through a standard 9-pin D-Type female socket (JD1) or via the USB port on the optional relay card fitted to Slot 2. Only one communication port can be active at a time and the priority is given to the USB port.

This interface allows the UPS to be connected to a computer, and when used with appropriate power management software, such as WAVEMON, it allows the computer to continuously monitor the input mains voltage and UPS status, and display messages in response to any UPS system changes.

USB Port

To establish communication between the UPS and a computer, connect the USB cable that is supplied with the UPS between the UPS USB port and the USB port on the computer. The USB port is compliant with USB 1.1 protocol.

JD1 RS232 Port

JD1 is a standard 9-pin D-Type female socket which provides an intelligent RS-232 serial port. Figure 8.4 shows the connector pin-out. Note that the maximum length for the interconnecting RS232 cable is 15m.

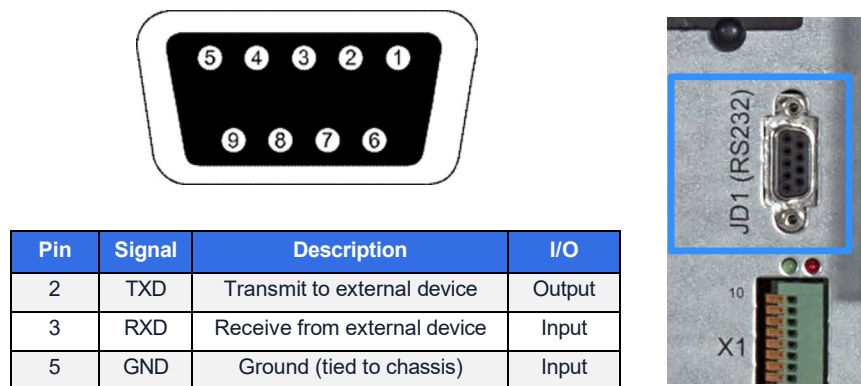

Figure 8.4 Connector Cable - PC Serial Port

8.5 RS485 Interface for multidrop

Multidrop cables are connected between the modules in a parallel module system to enable the system to be remotely monitored over Ethernet. The cables (supplied) are terminated with RJ45 plug connectors that fit into the multi-drop socket on the communications interface board (see Figure 8.5). An RJ45 splitter plug (supplied with the fitting kit) is required when fitting the cables to the 'middle' cabinets.

1. Connect a multidrop cable between the communications interface board in UPS cabinet 1 and UPS cabinet 2, using a splitter plug in cabinet 2 if it is a 'middle' cabinet.
2. Connect a multidrop cable between the communications interface board in UPS cabinet 2 and UPS cabinet 3, using a splitter plug in cabinet 3 if it is a 'middle' cabinet.
3. Continue with the above steps until a multidrop cable is connected as a daisy chain between all modules.

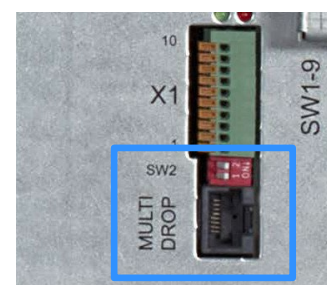

Figure 8.5 Multi-drop

8.6 SNMP Card slots

Simple Network Management Protocol (SNMP) is a world-wide, standardised communication protocol that can be used to monitor any network-connected device via a simple control language, and display the results in an application running within a standard web browser.

The REHLKO PW 6000 (60-120 kVA) communications interface board contains an SNMP slot (SLOT 1) which is designed to house a Modem/Ethernet SNMP adapter card. Alternatively, SNMP connectivity can be implemented using an external SNMP adapter connected to the communications interface board RS232 output (JD1).

The SNMP/Ethernet adapter contains an RJ-45 connector which allows it to be connected to a network using a standard network cable. Once connected, the UPS-Management software agent, which is already installed in the SNMP adapter, then monitors the UPS operating parameters and communicates the operating data with the connected PC. In a parallel module UPS system the SNMP interface can communicate 'system-wide' data, or data for an individual UPS module.

The SNMP card enables event/alarm emails, server shutdown (with optional licenses) and other tasks. It can also be integrated with BMS software over a local area network (LAN) for SNMP or Modbus information over IP.

An optional card enables Modbus comms over RS485.

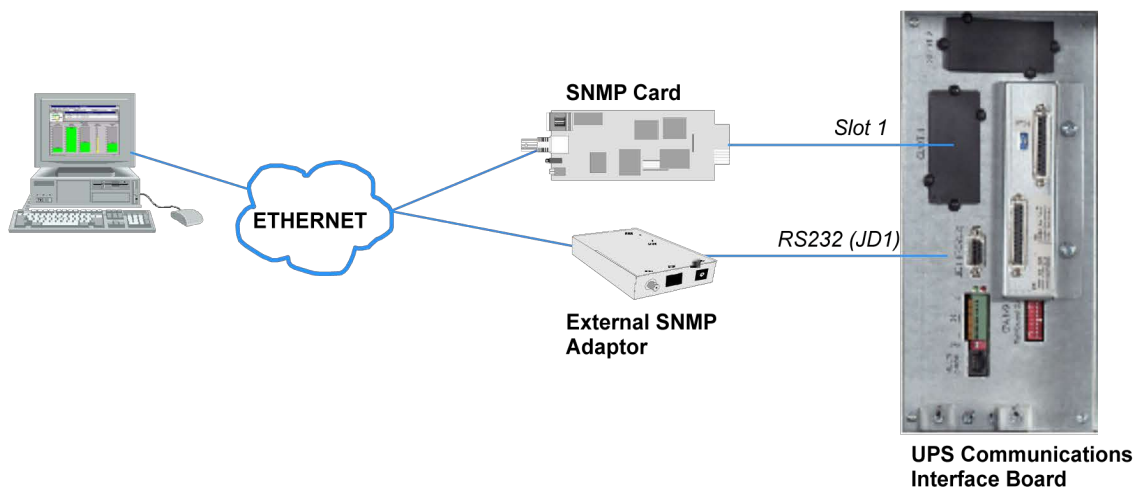

Figure 8.6 SNMP Internal and external adapters

8.7 UPS Monitoring and automated control software

8.7.1 The importance of UPS management

The utility supply is inevitably unreliable every now and then; and assuring continuous power to all the facilities connected to it can be a difficult task. The situation is further complicated if worldwide systems are managed via a Local Area Network (LAN) or Wide Area Network (WAN).

However, by interfacing the REHLKO PW 6000 (60-120 kVA) UPS system with purpose-designed network management tools, a System Administrator can take measures to back-up data, and prevent system errors or data loss, in the event of a relatively long utility supply outage. Suitable UPS management software can also enable a System Administrator to monitor all attached networks from a central point and identify bottlenecks at an early stage.

In spite of extensive system monitoring, serious damage can still occur if an administrator fails to intervene in a timely manner, and it is therefore important that the installed UPS software can react automatically in such an event and shut down the supplied system in a safe and controlled manner.

Rehlko considers it important to have a complete solution for its UPS systems and offers its customers a number of remote control and monitoring tools to provide optimum protection.

9. Specification

9.1 GENERAL SPECIFICATIONS

MECHANICAL CHARACTERISTICS 60-120kVA (No Battery Enc.)					
Rating (kVA)		60	80	100	120
Dimensions (WxHxD)	mm	615 x 1954 x 480			
Dimensions with elevation kit (WxHxD)	mm	615 x 1978 x 480			
Weight (without batteries)	kg	198	206	228	230
Colour		Black (RAL 9005)			
Batteries		Fitted in external battery cabinet or enclosure			
Input and output power cable entry		Bottom with front access for connection			
Cooling air		Front entry, top exit			

SYSTEM CHARACTERISTICS					
Topology		On-line, double conversion, Voltage and Frequency Independent (VFI)			
Technology		Second generation transformerless design			
Parallel configuration expansion		For added redundancy and/or capacity a parallel system can be extended to up to 10 modules on request			
Double conversion AC/AC efficiency. With fully charged battery and linear load (PF = 1) (Tolerance of $\pm 0.2\%$)	Load	60	80	100	120
	100%	95.5%	95.5%	95.7%	95.7%
	75%	95.8%	95.8%	96.0%	96.0%
	50%	96.0%	96.0%	96.0%	96.0%
	25%	95.0%	95.0%	95.0%	95.0%
Eco mode efficiency	%	> 99.0			

INPUT CHARACTERISTICS		60	80	100	120
Input voltage	V	3x 380/220V+N, 3x 400/230V+N, 3x 415/240V+N			
Input voltage tolerance (ref to 3x400/230V) for Loads in %	V	(-10% to +15%) for <100 % load (-20% to +15%) for < 80 % load (-30% to +15%) for < 60 % load			
Input frequency	Hz	35-70			
Overvoltage Category		II(2500Vpk)			
Backfeed Protection		Optional			
Inrush current	A	Limited by soft start			
Max. Input Power with rated output power and charged battery (pf=1.0)	KW	64	85	105	126
Max. Input Current with rated output power and charged battery (pf=1.0) [@400/230V]	A	92	122	152	183
Max. Input Power with rated output power and discharged battery (pf=1.0)	KW	70	93	116	139

INPUT CHARACTERISTICS		60	80	100	120
Max. Input Current with rated output power and discharged battery (pf=1.0) @400/230V	A	101	134	167	201
Input power factor (leading)		> 0.99 @100% load			
Input harmonic distortion (THDi) (%)		< 4% @100% load			
Rated short time withstand current		10kA for 1.5 seconds			
AC Power distribution system		TN-S, TN-C, TN-C-S, TT			
Required input connection		3 phases an neutral required			

BATTERY CHARACTERISTICS		60	80	100	120
Battery type		Maintenance-free VRLA, vented lead-acid, NiCd			
Variable number of 12V battery blocks	No.	42-48 Autonomies >60 min are only available for loads < 90%. For loads between 90-100%, the maximum allowed autonomy is 60 mins. For autonomy's less than 20 mins UPS supports 42-50 x12 V blocks			
Variable number of 1.2V NiCd cells	No.	420-480 Autonomies >60 min are only available for loads < 90%. For loads between 90-100%, the maximum allowed autonomy is 60 mins. For autonomy's less than 20 mins UPS supports 420-500 x1.2V cells			
Max. battery charger current	A	37	49	61	61
Max. battery charger power	kW	18	24	30	30
Battery float voltage (VRLA / NiCd)	VDC	2.25 / 1.40			
End of discharge voltage (VRLA / NiCd)	VDC	1.65 / 1.05			
Temperature controlled charger		Yes (temperature sensor optional)			
Ripple current (rms)	%	2% of the battery capacity			
Battery test		Automatic and periodic (adjustable)			

OUTPUT CHARACTERISTICS		60	80	100	120
Output rated power (@min 42 battery blocks)	kVA/ kW	60/60	80/80	100/100	120/120
Load power factor rated		1.0			
Output current (In) (PF=1.0) (@min 42 battery blocks)	A	87	116	145	174
Output rated voltage	V	3x 380/220 or 3x 400/230 or 3x 415/250			
Output waveform		Sinewave with 0deg. phase imbalance @100% unbalanced load			
Output voltage stability (normal/battery mode)	%	± 1.5 / ± 1.5			
Total harmonic distortion with 100% load operating in normal mode	%	< 2 with linear load			
Total harmonic distortion with 100% load operating in battery mode	%	< 2 with linear load			
Voltage transient and recovery time with 100% step load	%/ sec	< 4% (linear load)			
Output frequency	Hz	50 or 60			
Output frequency tolerance	%	±0.1 free-running, quartz oscillator ±2 or ±4 (selectable) with mains synchronised			
Frequency slew rate	Hz/s	1.0			

OUTPUT CHARACTERISTICS		60	80	100	120
Max synch phase error	°	< 2° (referred to a 360° cycle)			
Permissible unbalanced load	%	100% (all 3 phases independently regulated)			
Overload capability on inverter	% / min	150% load for 30 seconds 125% load for 5 minutes 110% load for 20 minutes			
Fault clearing capability (100ms)	A	2x In for normal mode and battery mode			
Bypass short circuit capability	A	10x rated In for 10ms			
Crest factor		3:1			
* With 50 battery blocks only					

STATIC BYPASS		60	80	100	120
Transfer time	ms	< 1.0 Inverter to bypass < 5.0 bypass to inverter < 6.0 in ECO mode			
Rated current	A	87	116	145	174
Bypass mode fault clearing capability	A	10x In for 20ms (with recommended fuses fitted)			
Overload protection on bypass mode	%/ min	150% load for 30 seconds 125% load for 5 minutes 110% load continuously			
Maintenance bypass		Fitted as standard			
Bypass protection fuses or circuit breaker		Not included			

ENVIRONMENTAL CHARACTERISTICS		60	80	100	120
Audible noise @ 100/50% load	dBA	< 64/59	<64/60	< 64/61	< 64/59
Ambient temperature for UPS	°C	0-40			
Temperature for batteries (recommended)	°C	20			
Battery storage time (at 20°C)		Maximum 6 months			
Fan assisted cooling air flow		Front entry, top exit			
Heat dissipation with 100% linear load	W	2850	3800	4750	5700
	BTU/h	9730	12970	16220	19460
Heat dissipation with 100% non-linear load(acc.to 62040-3)	W	3158	4211	5264	6316
	BTU/h	10778	14371	17964	21557
Heat dissipation without load	W	410	530	640	640
Relative air-humidity		< 95% (non-condensing)			
Max altitude above sea level without derating		1000m (3300ft) without derating			
De-rating factor for use at altitudes above 1000m sea level according (IEC 62040-3)		Height above sea level (m/ft) 1500 / 4850 2000 / 6600 2500 / 8250 3000 / 9900			

STANDARDS	
Safety	IEC/EN 62040-1
Electromagnetic compatibility	IEC/EN 62040-2
Performance	EN 62040-3:
Product certification	CE UKCA
Degree of protections	IP20
Manufacturing	ISO 9001, ISO 14001:2004

COMMUNICATION OPTIONS	
Power Management Display (PMD)	LCD display and mimic diagram showing UPS operational status
Customer Interfaces: (Dry Ports)	Volt-free output interface provide status and alarm outputs for remote indication and interfacing with BMS systems. Together with customer inputs interface for connecting an Emergency Stop, On Generator status etc.
RS232 on Sub-D9 port	For monitoring and integration in network management
RS485 on RJ45 port	Remote monitoring system with graphical display (option)
RS485 on RJ45 port	For multidrop purposes (option)
Slot for SNMP Card	Ethernet card for monitoring and integration in network management (option)
Slot for SNMP Card	USB Port and relay card. Customer outputs