



# REHLKO *PW* 8000DPA (RI)

Modular three-phase uninterruptible power supply

(Up to 80 kVA/kW)

User Manual



Document Control	1
Useful Contacts	1
<b>1: Safety</b>	<b>1</b>
1.1 Description of symbols used in this manual	1
1.2 User precautions	1
1.3 Declaration of Safety conformity and CE marking	2
<b>2: General Description</b>	<b>3</b>
2.1 Introduction	3
2.1.1 Reliability and quality standards	3
2.2 Rehlko PW 8000DPA RI system	3
2.2.1 System configuration	3
2.2.2 Advanced Design Features	4
2.3 Functional description of operation	5
2.3.1 UPS Power module internal operation	6
2.3.2 UPS module operational states	7
2.3.3 Parallel system operation	9
2.3.4 UPS system operation	10
2.4 Component identification	12
2.5 Module control panel	14
2.5.1 Module mimic LED indicators	14
2.5.2 Operator buttons	15
2.5.3 LCD Power management display	16
2.6 PW 8000DPA RI Communication interface	18
2.6.1 Introduction	18
2.7 Warranty	20
2.7.1 Extended Warranty	20
2.8 Contacting service	20
<b>3: Installation Planning</b>	<b>21</b>
3.1 Introduction	21
3.2 Environmental and mechanical planning	21
3.2.1 Environmental considerations	21
3.2.2 Installation	22
3.3 Electrical and cabling planning	23
3.3.1 General requirements	23
3.3.2 Cable and fuse sizing	24
3.4 External maintenance bypass	31
<b>4: Installation Procedure</b>	<b>32</b>
4.1 Introduction	32
4.2 Taking receipt of the UPS	32
4.2.1 Reporting transportation damage	32
4.2.2 Local transportation	33
4.2.3 Storage	33
4.3 Unpacking	34
4.4 Mechanical installation	35
4.5 Power cabling	43
4.5.1 Safety notes	43
4.5.2 Power connections	44
4.5.3 Connecting the power cables (single-feed input)	46
4.5.4 Connecting the power cables (dual-feed input)	46
4.5.5 Connecting the UPS output cables	46
4.5.6 Connecting the battery	47
4.6 Remote monitoring and control facilities	47
4.6.1 PW 8000DPA RI (S2) communications interface	47
4.7 Installation completion	47

<b>5: Operating Instructions</b>	<b>48</b>
5.1 Introduction	48
5.1.1 Operating procedure summary	48
5.1.2 General warnings	48
5.2 How to start the UPS system from a fully powered-down condition	50
5.3 Operating in ECO (on bypass) mode	52
5.3.1 How to power-up the UPS system and operate in ECO (on bypass) mode	52
5.3.2 How to transfer to ECO (on bypass) from on-line (on inverter) mode	52
5.3.3 How to transfer to on-line (on inverter) fro ECO (on bypass) mode	53
5.3.4 How to Turn OFF the UPS system when operating in ECO (on bypass) mode	53
5.4 How to transfer the load to the maintenance bypass	54
5.5 How to shut down the complete UPS system	56
<b>6: Maintenance</b>	<b>57</b>
6.1 Introduction	57
6.2 User responsibilities	57
6.3 Battery testing	58
<b>7: Troubleshooting</b>	<b>59</b>
7.1 Alarms	59
7.2 Module control panel	59
7.3 Troubleshooting table	60
7.4 Contacting service	60
<b>8: Options</b>	<b>61</b>
8.1 Customer communications	61
8.1.1 Customer control inputs (X1)	61
8.1.2 Dry port outputs (X2)	63
8.1.3 Backfeed Protection	64
8.1.4 Serial RS232 Computer interface – USB & JD1 (Smart Port)	65
8.1.5 Network interface card slots	65
8.2 UPS Monitoring and automated control software	66
8.2.1 The importance of UPS management	66
8.2.2 SNMP monitoring software	66
8.2.3 WAVEMON UPS monitoring and control software	66
8.2.4 PowerREPORTER™ management software	67
<b>9: Specification</b>	<b>69</b>
9.1 Mechanical characteristics	69
9.2 UPS Module characteristics	70
9.3 Battery Characteristics	72
9.4 Communication Options	73
9.5 Standards	73

# 1. Safety

## 1.1 Description of symbols used in this manual



**WARNING:** The warning symbol is used where there is danger of an electrical shock, equipment damage or personal-injury.



**CAUTION:** The caution symbol is used to highlight important information to avoid possible equipment malfunction or damage.

## 1.2 User precautions



**WARNING:** Keep this manual with the UPS for future reference.



**WARNING:** The UPS and peripheral equipment must be installed by suitably qualified and trained personnel who are aware of the potential shock hazards.



**WARNING:** Do not attempt to install this UPS system until you have read and understood ALL the safety instructions and hazard warnings contained in this manual.



**WARNING:** High leakage current!  
Ensure that the UPS has been correctly earthed before you connect the mains power supply



**WARNING:** Do not apply electrical power (AC or DC) to the UPS before it has been commissioned by a fully trained engineer authorised by Rehiko.



**WARNING:** All servicing must be performed by a Rehiko approved engineer.



**WARNING:** Do not attempt to service the UPS yourself. You run risk of exposure to dangerous voltages if you open or remove the UPS covers!



**WARNING:** Rehiko will assume no responsibility or liability for accidents or injuries due to incorrect operation or manipulation of the UPS or peripheral equipment.



**CAUTION:** The Rehiko PW 8000DPA RI is a Class A UPS product (according to EN 62040-3). In a domestic environment the UPS may cause radio interference. In such an environment the user may be required to undertake additional measures.

### 1.3 Declaration of Safety conformity and CE marking

The Rehlko PW 8000DPA RI UPS system is designed and manufactured in accordance with Quality Management Systems standard EN ISO 9001. The CE marking indicates conformity to the EEC Directive by the application of the following standards in accordance with the specifications of the harmonized standards:

- 2006/95/EC Low voltage directive
- 2004/108/EC Electromagnetic Compatibility directive (EMC)

**Standards as reference:**

- EN-IEC 62040-1  
Uninterruptible power supply (UPS). Part 1-1: General and safety requirements for UPS's used in accessible areas by end users.
- EN-IEC 60950-1  
IT equipment. Safety. Part 1: General requirements
- EN-IEC 62040-2  
Uninterruptible power supply (UPS). Part 2: EMC requirements
- EN-IEC 62040-3  
Uninterruptible power systems (UPS). Part 3: Performance and test requirements
- 2011/65/EU  
Restriction of the use of certain hazardous substances (RoHS) DIRECTIVE

The supplier's responsibility is excluded if the customer modifies, or intervenes with, this product in any way.

	Product Standards	Standards
Safety	EC/EN 62040-1	EC/EN 60950-1
Electromagnetic Compatibility (EMC)	IEC/EN 62040-2 (C1) Emission cat. C3 Immunity cat. C3	IEC/EN 61000-4-2 IEC/EN 61000-4-3 IEC/EN 61000-4-4 IEC/EN 61000-4-5 IEC/EN 61000-4-6 IEC/EN 61000-4-8 IEC/EN 61000-2-2
Performance	EN-IEC 62040-3 2011/65/EU	VFI-SS-111
RoHS	EN50581	EN50581

# 2. General Description

## 2.1 Introduction

Congratulations on your purchase of the Rehiko PW 8000DPA RI UPS system.

It is widely accepted that continuous power availability is essential in today's dynamic IT and process-reliant work environments; however, it is equally important that any installed power protection system is sufficiently resilient and adaptable to handle changes brought about by the introduction of new server technologies, migration and centralization.

Such demands are well met by the PW 8000DPA RI UPS system, which provides the foundation for continuous power availability of network-critical infrastructures both in enterprise data centres, where business continuity has paramount importance, and in process control environments, where manufacturing continuity is essential.

### 2.1.1 Reliability and quality standards

The PW 8000DPA RI is a truly modular UPS system using a third generation high-power-density (HPD), leading-edge, double-conversion design. Its advanced double conversion Voltage and Frequency Independent (VFI) topology responds fully to the highest availability and environmentally friendly requirements compliant with IEC 62040-3 (VFI-SS-111) standards.

Rehiko specialises in the installation and maintenance of Uninterruptible Power Systems; and this powerful UPS is just one example of our wide range of state-of-the-art power protection devices that can provide your critical equipment with a steady and reliable power supply for many years.

## 2.2 Rehiko PW 8000DPA RI system

The Rehiko PW 8000DPA RI is a rack-independent, modular design that is available in a range of seven rack/sub-rack assemblies comprising the UPS module(s), switch panel, battery tray(s), power connectors and a number of optional communication facilities. The UPS modules themselves are available as either 10 kW or 20 kW units.



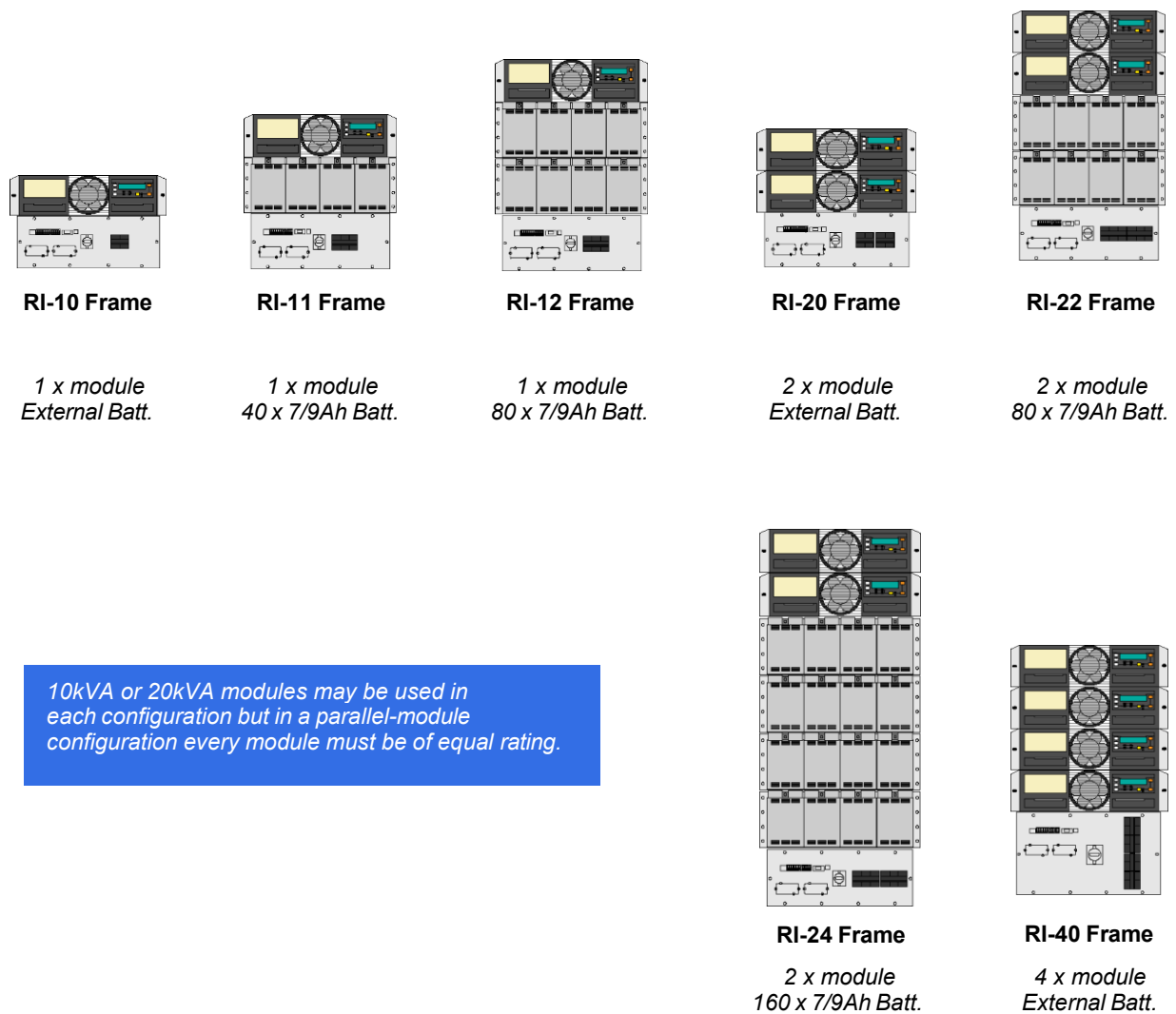
**Key Point:** All the UPS modules fitted within a sub-rack must be of the same rating.

### 2.2.1 System configuration

The available rack/sub-rack configurations are described in Table 2.1 below, and illustrated in Figure 2.1.

**Table 2.1 Available sub-rack configurations**

FRAME	MAX OUTPUT	BATTERY
PW8000-RI 10	20 kW (1x 20kW)	External
PW8000-RI 11	20 kW (1x 20kW)	Internal (1 string of 40x 12V blocks)
PW8000-RI 12	20 kW (1x 20kW)	Internal (2 strings of 40x 12V blocks)
PW8000-RI 20	40 kW (2x 20kW)	External
PW8000-RI 22	40 kW (2x 20kW)	Internal (2 strings of 40x 12V blocks)
PW8000-RI 24	40 kW (2x 20kW)	Internal (4 strings of 40x 12V blocks)
PW8000-RI 40	80 kW (4x 20kW)	External



**Figure 2.1 Rehiko PW 8000DPA RI module configuration**

## 2.2.2 Advanced Design Features

### Hot swappable modules

Where the Rehiko PW 8000DPA RI frame contains two or more UPS modules – for example RI-20, RI-22, RI-24, RI-40 – the installed modules operate in parallel, with inter-module control signals ensuring that they remain fully synchronised to each other and the incoming mains supply, and equally share the connected load.

Thanks to the UPS module's advanced Distributed Parallel Architecture (DPA) design, it is possible to operate a multi-module frame with just a single module fitted and add the second/subsequent module(s) at a later date when it is necessary to increase the system capacity to match any designed increase in load demand.

This 'hot-swappable' design also allows a module in a parallel-module frame to be exchanged during UPS operation without needing to transfer the load to the bypass supply – of course this depends on the system redundancy and prevailing load demand.

Note that the frame Type Number takes the form of 'RI-XY' and identifies the number of UPS module and battery sub-racks (shelves) that are fitted to the frame. RI= Rack Installable, X= Max. No. of module, Y= Max No. of battery rows.

For example:

*RI-20 has provisions for two UPS modules and no batteries.*

*RI-22 has provisions for two UPS modules a two battery rows.*

*RI-24 has provisions for two UPS modules and four battery rows.*

### Advanced input booster/rectifier technology

The Rehiko PW 8000DPA RI UPS module's advanced booster technology results in an input power factor of 0.99 with a harmonic content of < 3% THD(i). This enhances the system reliability and minimises the winding losses of any generator or transformer connected to the UPS input, which in turn reduces the generator/transformer costs. It also overcomes the need for an input harmonic filter, resulting in further savings.

Cabling and fusing costs are also reduced as a result of the high input power factor due to the low reactive power consumption.

In summary, the benefits of the UPS module's high input power factor are:

- reduced cable losses
- no over-sizing of generators required
- no erratic operation of sensitive connected loads
- low input harmonic currents
- reduced heating of transformers and generators
- no false circuit breaker tripping and malfunction
- no resonance with power factor correction capacitors

### Flexible battery management

The Rehiko PW 8000DPA RI UPS includes, as standard, a flexible battery management system that provides intelligent battery charging and continuous battery condition monitoring. Together, these functions greatly reduce premature battery deterioration and prolongs battery life.

The major benefits are:

- ripple-free battery charging due to an independent dc-dc charger with no connection to the rectifier and inverter
- wide range of number of 12V battery blocks; depending on the required autonomy time
- the UPS's wide input voltage operating window extends the battery life due to fewer discharge cycles
- battery discharge protection caused by load jumps
- proactive battery protection from false manipulations and inadequate charging voltages
- proactive battery failure detection thanks to Advanced Battery Diagnosis (ABD) - algorithm
- user-selectable battery tests
- optional temperature-compensated charging to enhance battery life

### Decentralized Parallel Architecture (DPA)

The Rehiko PW 8000DPA RI system features Decentralized Parallel Architecture (DPA) paralleling technology that provides N+x parallel redundancy without introducing a single-point-of-failure. Utilizing the DPA technology, each parallel UPS module is completely autonomous, containing bypasses, CPUs, control panels and independent battery configuration.

## 2.3 Functional description of operation

This section describes:

- A block-diagram level explanation of the UPS module internal operation (*see paragraph 2.3.1*).
- The various operational states of the UPS module (*see paragraph 2.3.2*).
- UPS system-level operation – 'ON-LINE' versus 'OFF-LINE' UPS system operation (*see paragraph 2.3.4*).

### 2.3.1 UPS Power module internal operation

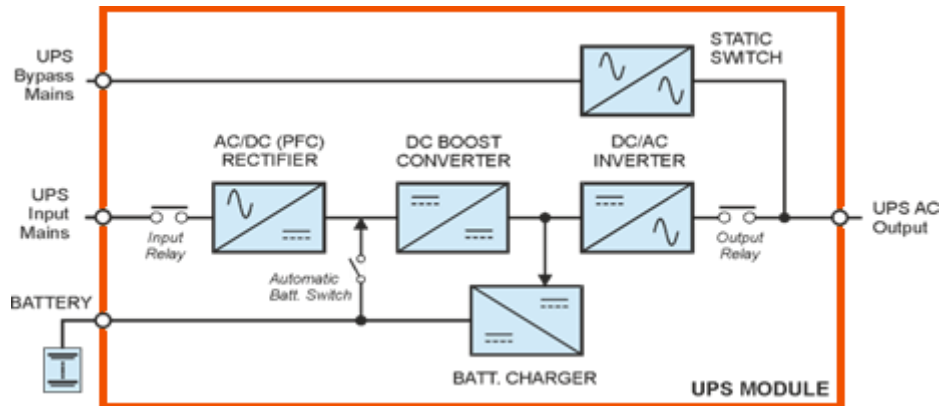


Figure 2.2 UPS module functional block diagram

#### UPS input/bypass mains supplies

Figure 2.2 illustrates separate UPS module input mains and bypass mains supplies. These two inputs can be connected to separate mains power sources or linked together at the UPS input power terminal blocks and fed with a single mains supply source. Where the UPS is cabled for separate mains inputs it is described as having a 'split-bypass' input; conversely, when the two mains inputs are linked together it is described as a 'common-bypass' input. These terms are used throughout this book, especially in the installation chapters.

#### Rectifier (PFC controlled converter)

The rectifier converts the UPS input mains to a DC power source that can satisfy the inverter power demands at 100% load. This is possible with a UPS input mains voltage range of -20% to +15%. This wide input voltage operating range means that the battery is not called upon during substantial power dips (brown outs), which in turn maximises the UPS battery life and availability. The rectifier uses leading-edge switched-mode techniques that result in a module input power factor of almost unity over its complete operating range (0.99 at full rated linear load).

#### DC Boost converter

The DC boost converter converts the DC voltage connected to its input, from either the rectifier or battery, to a regulated DC voltage that is required by the inverter to operate efficiently.

#### Battery charger

A multi-stage battery charger, powered from the DC boost converter regulated output, charges the battery whenever the UPS input mains supply is available and the rectifier/boost converter is turned on. The charger uses an intelligent charging profile to obtain the best battery charge/discharge performance to optimise the battery life.

#### Inverter

The inverter converts the regulated DC voltage applied to its input into a sinusoidal AC output that is suitable for connecting to the load equipment. In addition to providing output voltage regulation, the inverter control logic also provides various levels of overload protection, frequency regulation and synchronisation, and output voltage error detection.

In a parallel-module installation (i.e. where two or more UPS modules fitted to the frame) the inverter control logic also ensures balanced load sharing between the on-line modules together with inter-module frequency synchronisation.

#### Static switch

The static switch provides a means of connecting the UPS AC output directly to the unregulated bypass mains supply.

Working in conjunction with the inverter and output contactor, the static switch control logic is able to transfer the UPS AC output (load) between the inverter and bypass supply without a break in the load supply. Load transfer between the inverter and bypass can be selected manually from the operator control panel and takes place automatically following a UPS fault that prevents the inverter from providing its correct output (including temporary overload situations).

*Note: A brief load break will occur when transferring from bypass to inverter following a bypass supply failure, or if the bypass/inverter are not synchronised when a transfer is demanded. (See 'Off Line Mode' in section 2.3.4).*

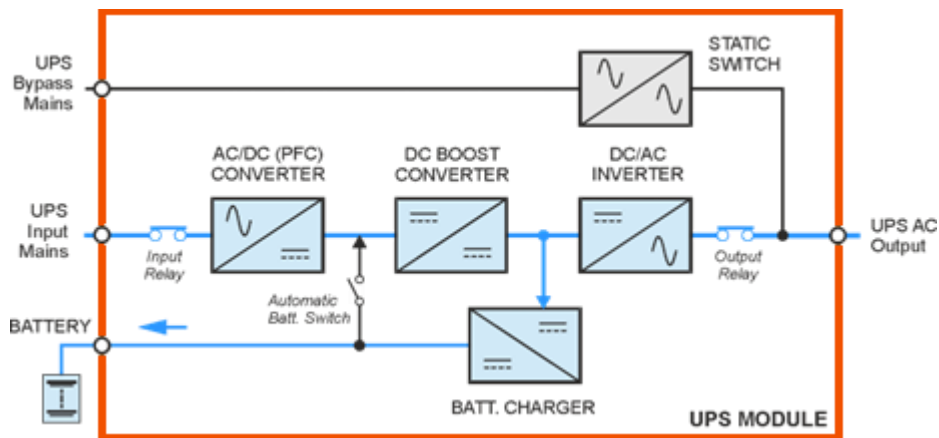
### Automatic battery changeover switch

If the UPS mains input supply fails, or undergoes a sustained dip (brownout), the automatic battery switch will close to connect the battery to the DC boost converter input. This enables the inverter to continue its normal operation and maintain the UPS output load supply from battery power.

### 2.3.2 UPS module operational states

Under normal circumstances the UPS module will operate in one of three states: On Inverter, On Battery or ON Bypass – these are described below.

#### UPS ON-INVERTER mode



**Figure 2.3 UPS ON-INVERTER**

Figure 2.3 illustrates the UPS ON - INVERTER mode, which is usually considered the 'normal' mode of operation:

- The input relay is closed.
- The rectifier and DC boost converter are turned on to supply controlled DC power to the inverter input.
- The battery charger is operational and provides controlled battery charging.
- The inverter is operational and provides an AC output.
- The output relay is closed to connect the inverter output to the UPS AC output terminals to provide the load with processed power.
- The static switch is off.

### UPS ON-BATTERY mode

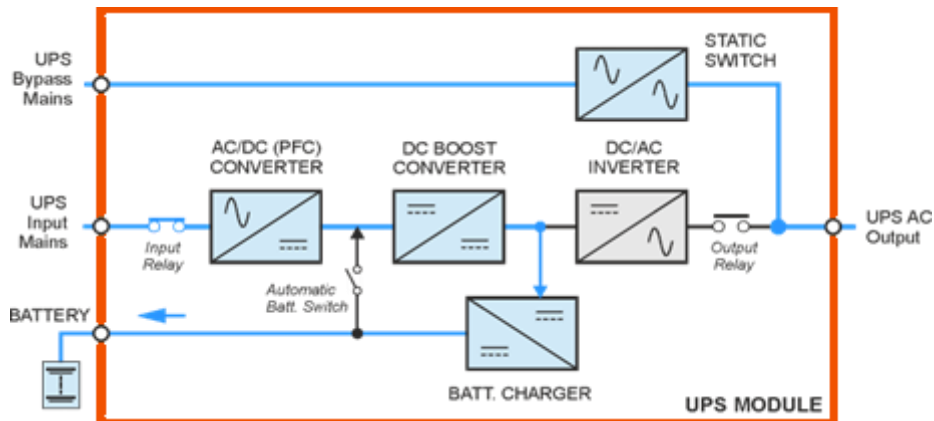


Figure 2.4 UPS ON-BATTERY

The UPS automatically changes to the ON-BATTERY mode if the mains input supply fails during normal operation:

- The rectifier is turned off.
- The automatic battery switch is closed.
- The battery discharges through the DC boost converter which remains fully operational and continues to provide the inverter with its regulated DC input.
- The inverter continues its normal operation (the changeover to battery power is transparent to the inverter).
- The output relay remains closed.
- The battery charger is turned off.
- The static switch is off.

### UPS ON-BYPASS mode

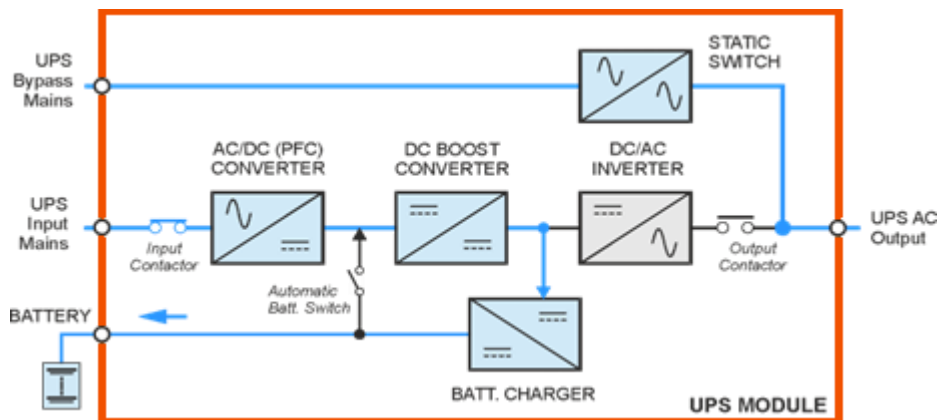


Figure 2.5 UPS ON-BYPASS

This mode can be selected by the operator as part of the system operating procedure. It is also entered following certain fault occurrences such as a UPS output overload:

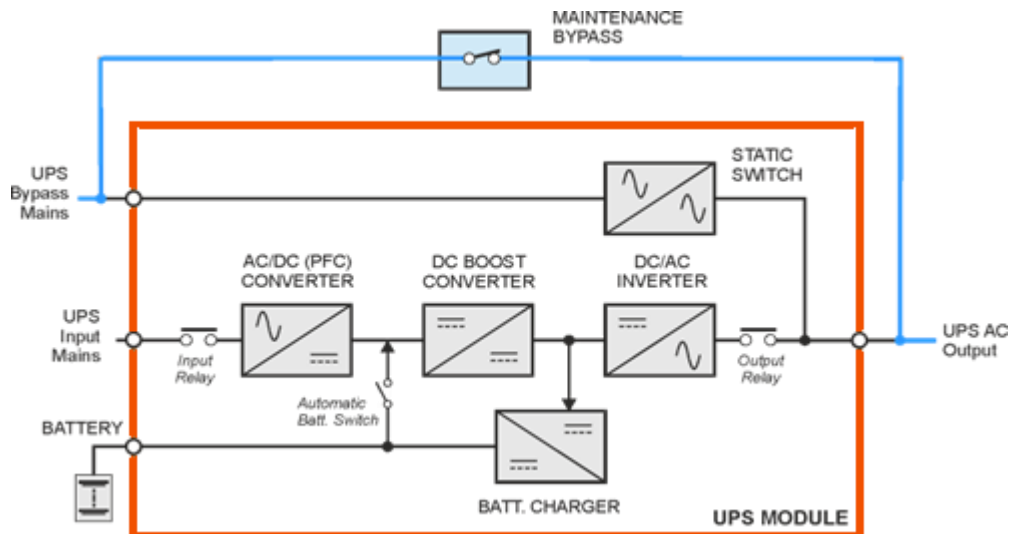
- The static switch is turned on to connect the load to the unregulated UPS bypass mains input.

Depending on whether or not the transfer to bypass was 'selected' or following a 'fault':

- The rectifier, boost converter and battery charger will remain active to maintain battery charging.
- The inverter may/may-not remain powered up and in operational readiness to be brought into use.

*Note: When operating in this mode the load is not protected against any mains input supply disturbances or loss.*

## UPS ON MAINTENANCE BYPASS



**Figure 2.6 UPS ON MAINTENANCE BYPASS**

Although the maintenance bypass switch is not fitted within the UPS module, the maintenance bypass mode of operation is shown here for completeness. A maintenance bypass switch is fitted to the UPS frame's switch panel and, when closed, it provides an alternative power path for the load which completely bypass the UPS module(s). This mode is primarily used to maintain the load supply when it is necessary to completely shutdown the UPS module for repair or module replacement. The maintenance bypass line is connected to the same unprotected supply source as that used by the static switch so for reasons of load security the UPS should only be operated in this mode when absolutely necessary.

### 2.3.3 Parallel system operation

Where two or more UPS modules are fitted in the rack (e.g RI-20, RI-22, RI-24, RI-40) the modules operate as a parallel UPS system and their AC outputs are connected in parallel at the frame's output terminals.

The electronic control system built into each UPS module ensures that:

- The UPS modules are always frequency-synchronised to each other – and to the bypass mains (when present).
- The UPS modules equally share the load current.
- The static bypass operation is synchronised such that if the operator selects 'Bypass' mode on one module the static switch in ALL the modules change over in unison.

### System expansion

Some UPS applications present a low initial power requirement which increases over time as the application grows – it is therefore essential that the installed UPS system can be expanded to meet the increasing demand without compromising the existing load. This requirement is well met with the 'hot swappable' nature of the Rehlko PW 8000DPA RI UPS modules, whereby an additional module can be inserted into a vacant slot within a parallel-module frame without the need to shut down the entire system or transfer it to the maintenance bypass.

### 'Capacity' system

When a system is described as being a 'capacity' system it implies that the potential full load requires ALL the fitted UPS modules to be operational – i.e. if one module trips off line due to a fault, the remaining module(s) will transfer the load to the static bypass supply and the load will no longer be protected from supply aberrations.

### 'Redundant' system

If a system is designed with module redundancy it must contain at least one UPS module over and above that which is necessary to power the applied load.

For example, a fully populated RI-40 frame (4 x 20 kW UPS modules) would operate with a redundancy of one module when connected to a 60 kW load. Under normal circumstances, with all four UPS modules operating, each module would provide 15 kW when the full 60 kW load is applied. But if one UPS module fails, or is taken off-line, the three remaining modules can sustain the load by each providing their rated 20kW output.

Clearly, the ability to lose a UPS module yet still supply the connected load with processed, backed-up power significantly increases the overall system reliability.

### 2.3.4 UPS system operation

#### Summary of UPS module operating modes

UPS installations are generally categorised as being either 'ON-LINE' or 'OFF-LINE' systems; and the PW 8000DPA RI can be configured to operate in either mode. The two systems are described below.

#### ON-LINE UPS system

An 'ON-LINE' system provides the highest degree of load protection, especially in the event of a mains supply disturbance or complete failure, and we always recommended its use if the critical load (e.g. computer system) will not tolerate even a very brief supply interruption.

When the PW 8000DPA RI is used as an 'ON-LINE' UPS it is configured to normally operate in the ON-INVERTER mode, as shown in Figure 2.3. In the event of a UPS input mains supply failure, the UPS changes to its ON-BATTERY mode (Figure 2.4) without affecting its output supply – i.e the UPS will continue to provide its rated output running from battery power and the changeover to battery operation is totally transparent at the UPS output.

If the UPS input mains supply returns when the module is operating on battery power the module will automatically revert to normal 'ON-LINE' operation once the returning input mains supply is validated.

If the UPS input mains supply does not return when the module is operating on battery power, it will continue to provide its rated output until the battery discharges to a low cut-off point, at which time the UPS will attempt to switch to its 'on bypass' mode; however, if the bypass input supply is unavailable the module will shut down in a controlled manner. An audible and visual alarm will warn the operator that the battery is discharging to enable any necessary intervention actions to be carried out to safeguard the load integrity (e.g. initiate a data backup).

It is usual, especially in larger installations, to provide the UPS with an alternative input supply from a standby generator which starts automatically following a mains supply failure. If such a standby UPS input power source is made available it means that the batteries discharge only until the generator comes on-line. This not only avoids the UPS from eventually shutting down due to discharged batteries but the short battery discharge period also increases the battery life cycle.

#### Bypass supply and fault handling

If the UPS experiences an internal fault during ON-LINE operation, the inverter is turned off and the static switch transfers the load to the bypass supply automatically and without interruption provided the inverter and bypass supplies are synchronised (Figure 2.5). In the event of an output overload the inverter is designed to supply the load for a limited time, depending on the overload severity, and if the permitted time is exceeded the load is transferred to the static bypass. The additional power available from the bypass supply will attempt to clear the overload but if it persists it will ultimately rupture the bypass supply fuses. If the overload condition clears while operating on bypass the load will be transferred back to the inverter and the UPS will return to its normal ON-LINE mode of operation.

#### OFF-LINE (On stand-by) UPS system operation

When the PW 8000DPA RI is used as an 'OFF-LINE' UPS system it is normally operated in its ON BYPASS mode (Figure 2.5) with the load supplied via the bypass line. However, the rectifier, DC boost converter and battery charger are all operational to maintain battery charging, and the inverter section is turned on but operating on standby.

In the event of a bypass supply failure, the inverter is immediately brought on line and the load is transferred from the bypass line to the inverter by the static switch within 3 to 5 milliseconds. If the UPS bypass and mains inputs are connected to separate sources and the mains supply is still live when the transfer takes place then the UPS will operate in its ON-LINE mode (Figure 2.3). However, if these supplies are connected to a common source the UPS will immediately revert to its ON-BATTERY mode (Figure 2.4).

When the bypass supply returns to normal, the load is re transferred back to the bypass line and the inverter returns to its standby operation.

Operating in this mode is slightly more energy efficient than operating in the ON-LINE mode due to the reduced rectifier and inverter losses during normal system operation; and it is sometimes referred to as the 'ECO' (economy) mode. However, this mode is recommended only if the connected load equipment can tolerate power interruptions of up to 3~5 ms during the transfer period.



**WARNING:** The ON-LINE mode should always be used for critical load protection.

### Control panel mimic indications

The module control panel mimic led indications for the ON-INVERTER and ON-BATTERY mode are shown below:

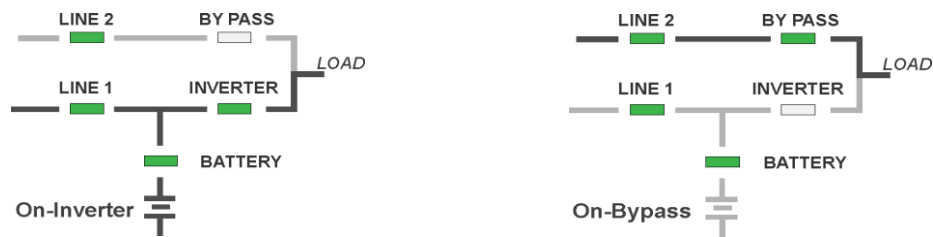
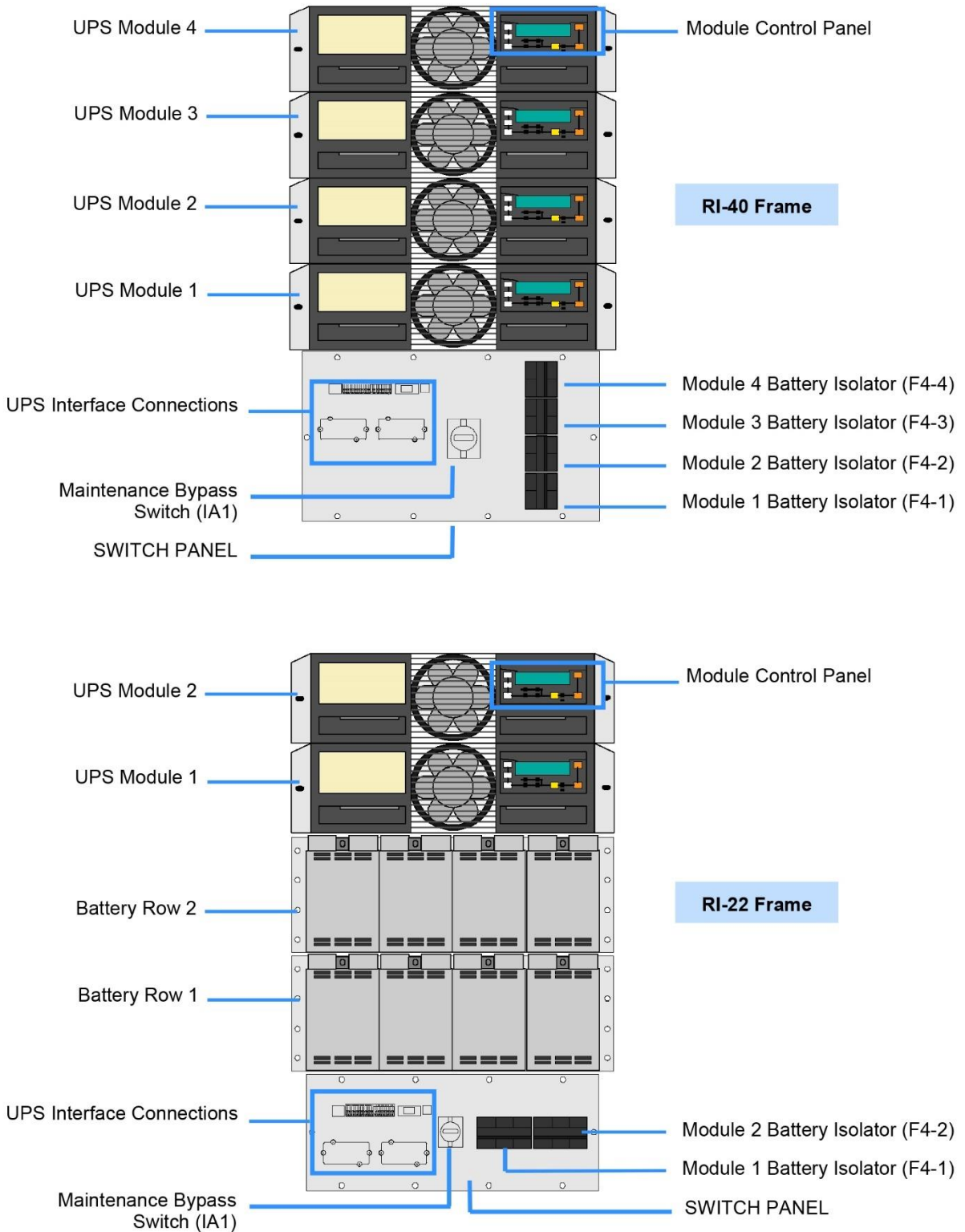


Figure 2.7 Control panel mimic indications

## 2.4 Component identification



**Figure 2.8 PW 8000DPA RI Component identification (front)**

All the UPS control panels and power switches are accessible from the front of the frame, as shown in Figure 2.8.

## UPS Modules

The rack-mounted UPS modules have sliding guides on the lower left and right sides to ensure that the module is inserted correctly. The module plugs in to fixed electrical connectors fitted to the back of the shelf. A heavy-duty power connector carries the UPS input, bypass, battery and AC output connections, and an additional connector carries the UPS parallel control connections together with the external interface cables.

Note that in a parallel module system the modules are numbered from 1 upwards, with module 1 fitted on the sub-rack lowest shelf. When upgrading a parallel module system that has spare capacity, additional modules must be inserted in the order shown in Figure 2.8.



**WARNING:** The UPS module weighs 21.5 kg and requires two persons to safely lift the unit when fitting or removing it.

### Maintenance bypass switch

The maintenance bypass switch provides a complete wrap-around, connecting the UPS AC output to the raw bypass mains supply. It should only be operated when the UPS system is operating on static bypass. Always follow the operating closely instructions when using this switch.

### Battery isolator(s)

A 2-pole battery isolator (F4-x) is provided for each UPS module in a parallel module system. If the batteries are mounted within the UPS rack (e.g. RI-22) then the battery string positive and negative cables are connected directly to the isolator. If the battery installation is external to the UPS rack (e.g. RI-40) then the external battery strings are connected to the battery terminals of the UPS power terminal block, which are in turn connected to the frame's F4-x battery isolator(s). Note that where an external battery cabinet/frame is used, it must also contain a fused three pole battery isolator for each battery string.

Battery installation details are provided later in this manual but note that all battery cabling must be carried out by a Rehiko approved engineer as part of the system commissioning procedure.

### UPS Interface connections

A range of interface facilities are provided to permit the UPS to remotely monitored and controlled. These are described on page 18.

### Module control panel

An LCD control panel located on the front of each UPS module is used for day-to-day UPS operation and performance monitoring.

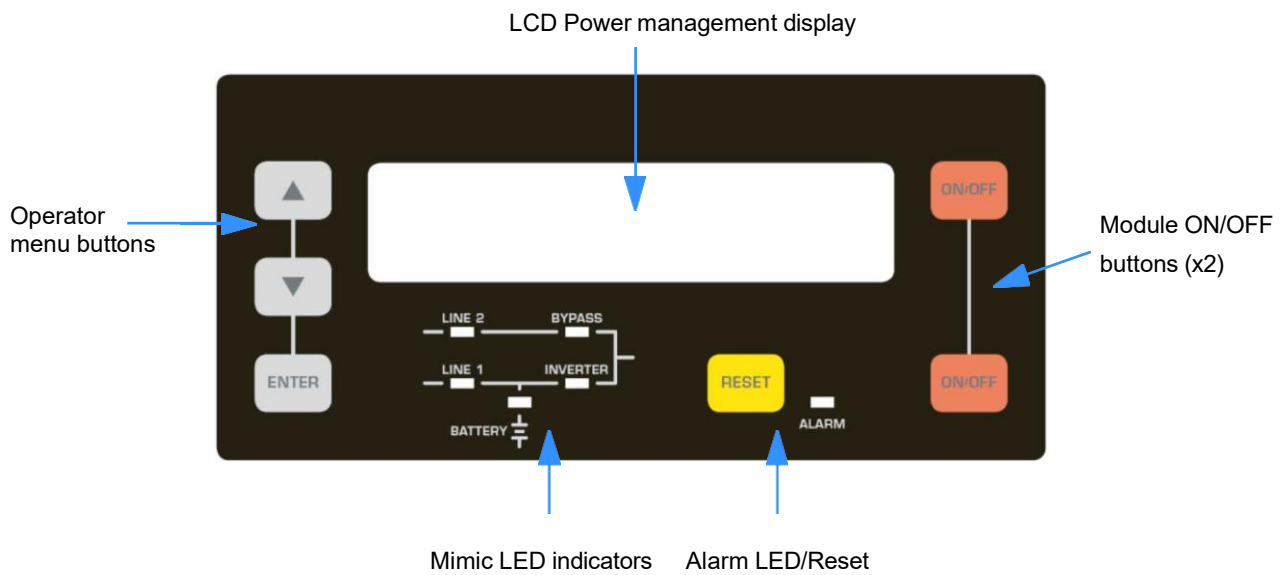
From the UPS control panel the operator can:

- Stop and start the UPS module
- Transfer the UPS AC output (load) between the inverter and bypass
- Monitor the UPS input/output voltage, current and frequency
- Monitor the battery charge / discharge current, and battery status
- Interact with monitored alarm and warning messages
- Configure the UPS operating parameters (\*service mode)
- Interrogate the UPS operating events and alarm history (\*service mode)
- Carry out diagnostic procedures (\*service mode)

*\*Note that the service mode is password protected to restrict its use to trained service personnel.*

The module control panel is described in detail below.

## 2.5 Module control panel

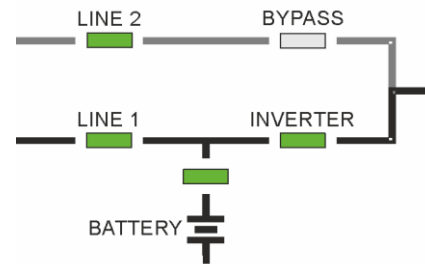


**Figure 2.9 LCD Control panel**

### 2.5.1 Module mimic LED indicators

The module mimic LED colours change between GREEN, RED and OFF to indicate the operational status of key UPS stages, and thereby serve to show the active power path through the UPS.

- LINE 1 (rectifier) and LINE 2 (bypass) LEDs indicate the availability of the input mains and bypass mains supplies respectively.
- INVERTER and BYPASS LEDs illuminate green to indicate which of the two sources is providing the UPS output supply.
- BATTERY illuminates green when the battery is being charged and flashes when the battery is discharging – e.g. when the inverter is operating from battery power. The indication change to red if the battery is faulty or fully discharged.
- Although it is not part of the module mimic, the ALARM LED, located



**Figure 2.10 Module mimic diagram**

towards the lower-right of the control panel, provides a visual indication that an alarm condition has been detected. When an alarm condition is present the LED is accompanied by an audible alarm.

## LED Indication summary

INDICATOR	STATUS	INTERPRETATION
LINE 1	GREEN RED	Input mains supply is available and within acceptable parameters Input mains supply is unavailable or not within acceptable parameters – this is the normal display during an input mains power failure
LINE 2	GREEN RED	Bypass mains supply is available and within acceptable parameters Bypass mains supply is unavailable or not within acceptable parameters
ALARM	OFF Flashing RED + buzzer RED	No alarm condition Alarm condition is currently active Alarm condition is present but the audible warning has been reset
INVERTER	OFF GREEN RED	Inverter turned OFF or the load is connected to the bypass Load on inverter Inverter is unavailable, or locked out
BYPASS	OFF GREEN RED	Bypass not operating (the module is turned OFF or the load is connected to the inverter) Load on bypass Static bypass is unavailable, or locked out
BATTERY	GREEN Flashing GREEN RED Flashing RED	Battery charger is ON and the battery is OK Load on battery and battery is discharging – normal display during input mains failure Battery faulty or discharged (e.g. high voltage, high temperature, failed battery test) Battery not detected. Battery is disconnected or battery fuse open, low battery voltage, (Note this is the default status before turning on the module).

### 2.5.2 Operator buttons

The operator buttons allow the user to:

- Set operating parameters and make adjustments via the menu-driven LCD display.
- Start and stop the UPS, and transfer the load between inverter and bypass.
- Monitor the UPS input/output voltage, current, frequency and other parameters – shown on the LCD display.

#### Button function summary

BUTTON	FUNCTION
ON/OFF	Used to switch-on or switch-off the UPS
UP (▲)	Scroll upwards through a displayed menu
DOWN (▼)	Scroll downwards through a displayed menu
RESET	Cancels the audible alarm. If the alarm condition was transient the ALARM LED will also extinguish, otherwise the LED will remain ON (red)
ENTER	Confirms (selects) a chosen menu item

The UPS can be switched ON or OFF by simultaneously pressing both ON/OFF buttons. The requirement to press both buttons is to help avoid accidental operation.

During normal operation, simultaneously pressing the two ON/OFF buttons will shut down the UPS module.

- In a single UPS module installation this will disconnect the UPS output unless the load is first transferred to the maintenance bypass – see the operating instructions.
- In a parallel module system the UPS module will shut down and its output will be disconnected from the parallel load bus. However, the load may or may-not transfer to bypass depending on the number of remaining live modules – i.e. if the number of remaining modules is sufficient to support the connect load then the load will not be transferred.

To shut down all the modules in a parallel system you must press both ON/OFF buttons on every module.

### 2.5.3 LCD Power management display

Working in conjunction with the UP, DOWN and ENTER buttons, the LCD screen presents a range of selectable menus which allows the user to operate the UPS and monitor its performance – the menu tree is shown in Figure 2.11.

#### Status screens

During normal operation the LCD displays a UPS status screen similar to those shown below. From the status screen the user can access the ‘top level’ menu by pressing either the UP or DOWN button; and then further navigate through the nested sub-menus using the UP / DOWN buttons to scroll, and the ENTER button to make a selection.

This status screen indicates that the UPS is operating ‘on inverter’ and providing protected power to the load.

LOAD PROTECTED	P01
-------------------	-----

This status screen indicates that the UPS is operating ‘on bypass’ and the load is therefore not protected.

LOAD NOT PROTECTED	P01
-----------------------	-----

This status screen indicates that the load is not being powered from the UPS, usually because the UPS has been switched off by the ON/OFF buttons.

LOAD OFF SUPPLY FAILURE	P01
----------------------------	-----

This status screen indicates that the UPS parallel switch (IA2) is open and the UPS module is disconnected from the parallel system. Although in a redundant parallel system the load might still be receiving protected power from the remaining on-line modules.

LOAD DISCONNECTED PARALLEL SWITCH OPEN	P02
---	-----

On the right hand side of the LCD status screen display is a three digit module ID indicator which shows a module’s position in a multi-module system.

- |     |   |
|-----|---|
| S   | Stands for <b>S</b> ingle module. The UPS frame only contains one UPS module  |
| P01 | Stands for <b>P</b> arallel system and 01 identifies the module as being the 1st module (MASTER) in the system  |
| P02 | Stands for <b>P</b> arallel system and 02 identifies the module as being the 2nd module (SLAVE) in the system. This number can range from 02 to 04 in a fully populated RI-40 UPS system. |

#### Top level menu

The following sub-menus can be accessed from the top level menu:

**EVENT LOG** – The event log stores the last 64 UPS events in date/time stamp order. These include both ‘fault’ events, such as [OVERLOAD], and ‘operational’ events such as [LOAD TO BYP .].

**MEASUREMENTS** – This sub menu provides access to a range of input, output and battery monitoring.

**COMMANDS** – This sub menu provides access to a range of commands that might be used during day-to-day UPS operation. Those most commonly accessed are the [LOAD TO INVERTER] and [LOAD TO BYPASS] command which are used to transfer the load between inverter and bypass during the UPS start-up and shut down procedures.

– [PERFORM BATT. TEST] Stops the charger and monitors the off-load battery voltage for 1 min. then transfers the load to battery for a further 1 min.

– [PERFORM DEEP BATT. TEST] Performs as above, but runs with battery on load until the low voltage alarm activates.

**UPS DATA** – This is a read-only menu and shows the UPS details input by the manufacturer/commissioning engineer.

**SET-UP USER** – This sub menu allows the user to select the LCD display language, set the local date/time which is used to stamp the Event Log, set up the automatic battery test operation and configure the UPS options when running on standby generator.

**SET-UP SERVICE** – This menu is used by the commissioning engineer and is password-protected to restrict access.

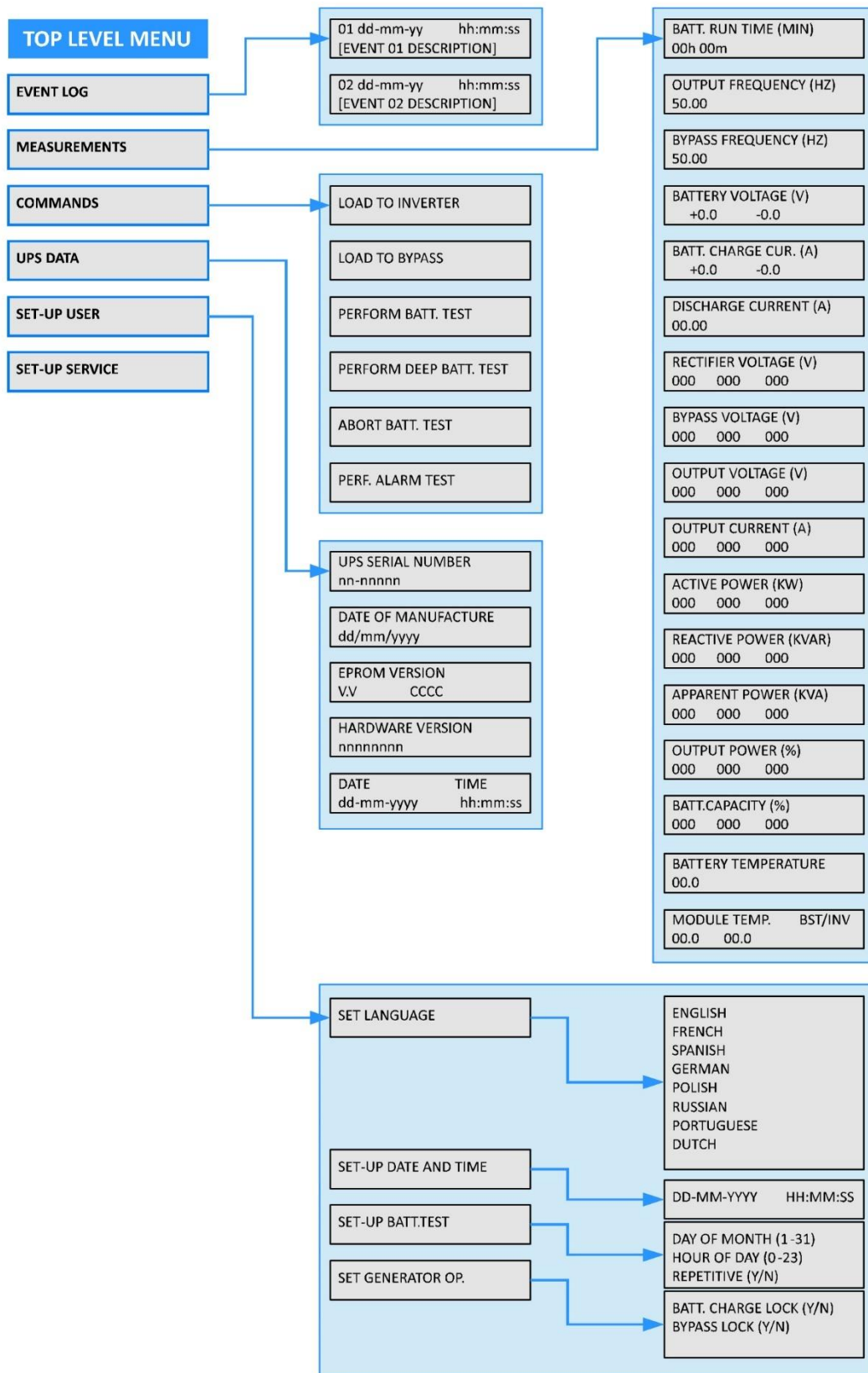
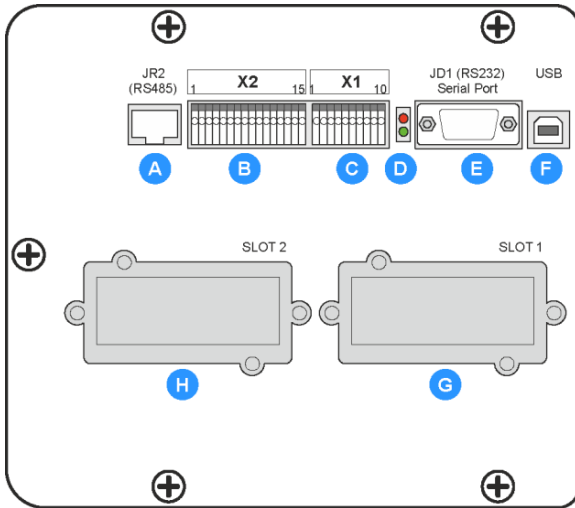


Figure 2.11 Module control panel menu

## 2.6 PW 8000DPA RI Communication interface



PW8000-RI Communications interface		
A	JR2	RJ45 Port: Network interface
B	X2	Customer output dry ports: Up to 5 output dry contacts used for signalling of the status of the UPS system (e.g. Mains failure, load on inverter, battery low, common alarm).
C	X1	Customer input dry ports: Up to 5 input dry contacts used for remote Shut Down and Generator Operation facilities, battery temp sensor or bespoke customer function.
D	LEDs	Status LEDs: 2 LEDs that indicate the Interface Board operational status
E	JD1	RS232 Smart port computer interface: Sub D9 female connector provides an RS232 user interface for remote systems monitoring.
F	USB	Standard USB interface: Provides a USB user interface for remote systems monitoring.
G	SLOT 1	Slot for optional modem/Ethernet card ONLY.
H	SLOT 2	Slot for optional SNMP card ONLY.

Figure 2.12 PW8000-RI Communications interface facilities

### 2.6.1 Introduction

The PW 8000DPA RI contains an interface board which provides a number of optional external interface connections, as illustrated in Figure 2.12. The interface facilities are described below, with detailed connection information provided in Chapter 8.

#### JR2 (RS485 Port) (A)

JR2 is an RJ45 connector. It provides an RS483 network interface, however this port is not currently used in the PW 8000DPA RI UPS system.

#### X2 – Dry port outputs (B)

X2 is a 15-way Phoenix terminal block that provides five, volt free switched outputs that can be used to interface the UPS with a range of customer's facilities. Typically these outputs are used to trigger remote alarm facilities, activate automated server intervention or interface the UPS power status with building management systems (BMS).

#### X1 – Dry port inputs (C)

X1 is a 10-way Phoenix terminal block that enables the connection of four remote control inputs that can be provided by external customer contacts. These inputs operate isolation relays on the UPS interface board and therefore require a +12 Vdc supply, which is sourced via terminals X1/9 (+12 Vdc) and X1/10 (Gnd).

These inputs are typically used to monitor an external remote shutdown command, on-generator status, high battery temperature warning etc.

#### Status leds (D)

The red and green status leds indicate the operating status of the UPS interface board. When illuminated, the red led indicates a circuit board fault that most likely requires a board replacement. The flashing rate of the green led indicates the board's status and normally flashes twice/second when the board is healthy.

### **JD1 (RS232) (E)**

JD1 is a Sub D-9 female connector that provides an RS232 user interface for remote systems monitoring using a computer application, such as WAVEMON. This allows the computer terminal to continuously monitor the mains voltage and computer operating status, and process any alarm messages.

### **USB (F)**

The USB port also provides a serial interface for remote systems monitoring and can be used as an alternative to JD1.



**Key Point:** Only one serial interface can be used at a time – i.e. either JD1 or USB port.

### **SLOT 1 (G)**

SLOT 1 can be used for an optional modem/Ethernet card.

### **SLOT 2 (H)**

SLOT 2 can be used with an SNMP interface card only.

## 2.7 Warranty

The PW 8000DPA RI UPS is supplied with a limited warranty that the UPS and its component parts are free from defects in materials and workmanship for a period of one year from the date of original commissioning or fifteen months from the date of original delivery, whichever is the sooner. This warranty is the only warranty given and no other warranty, express

This warranty is invalidated if the UPS is put into use without having first been commissioned by a fully trained and authorised engineer. This warranty does not apply to any losses or damages caused by misuse, abuse, negligence, neglect, unauthorised repair or modification, incorrect installation, inappropriate environment, accident, act of God or inappropriate application.

If the UPS fails to conform to the above within the warranty period then Rehiko will, at its sole option, repair or replace the UPS. All repaired or replaced parts will remain the property of Rehiko.

As a general policy, Rehiko does not recommend the use of any of its products in life support applications where failure or malfunction of the product can be reasonably expected to cause failure of the life support device or to significantly affect its safety or effectiveness. Rehiko does not recommend the use of any of its products in direct patient care. Rehiko will not knowingly sell its products for use in such applications unless it receives in writing assurances satisfactory to Rehiko that the risks of injury or damage have been minimized, the customer assumes all such risks and the liability of Rehiko is adequately protected under the circumstances



**CAUTION:** *The UPS system may contain batteries which must be re-charged for a minimum of 24 hours every six months to prevent deep-discharging. Batteries that have been, for whatever reason, deeply-discharged are not covered by the warranty.*

### 2.7.1 Extended Warranty

The Standard Warranty may be enhanced by protecting the UPS with an Extended Warranty Agreement (maintenance contract). An Extended Warranty Agreement enhances the standard warranty by providing:

- Regular preventative maintenance inspections
- Guaranteed speed of response to operational problems
- 24 hour telephone support
- Fully comprehensive (excluding batteries) cover

## 2.8 Contacting service

Rehiko has a service department dedicated to providing routine maintenance and emergency service cover for your UPS. If you have any queries regarding your UPS please contact us.

### UK

[www.ups.rehiko.co.uk](http://www.ups.rehiko.co.uk)

Rehiko web site

[ukservice.ups@rehiko.com](mailto:ukservice.ups@rehiko.com)

Service department – booking service, fault reporting etc.

[ukservicesales.ups@rehiko.com](mailto:ukservicesales.ups@rehiko.com)

Extended warranty agreements etc

### IRELAND

[www.ups.rehiko.ie](http://www.ups.rehiko.ie)

Rehiko web site

[ieinfo.ups@rehiko.com](mailto:ieinfo.ups@rehiko.com)

Service department, technical queries, hardware sales and extended warranty agreements

### SINGAPORE

[www.ups.rehiko.sg](http://www.ups.rehiko.sg)

Rehiko web site

[serviceups.sg@rehiko.com](mailto:serviceups.sg@rehiko.com)

Contract customer support, maintenance contracts renewals

# 3. Installation Planning

## 3.1 Introduction

A certain amount of pre-planning will help ensure a smooth and trouble-free UPS installation process. This chapter contains essential information concerning the environmental, mechanical and electrical requirements that should be considered when planning the installation of the PW 8000DPA RI UPS system.



**Key Point:** If you are installing an external battery cabinet supplied by Rehiko you should refer to the manual that is provided with the cabinet for installation instructions.

## 3.2 Environmental and mechanical planning

### 3.2.1 Environmental considerations

It is essential that the following environmental guidelines are observed when planning a suitable UPS location and operating environment.

1. The route between the off-loading point and the installation location must allow the equipment to be transported in an upright position.
2. The floor at the proposed installation site and en-route from the off-loading point must be able to safely take the weight of the UPS and battery equipment plus any transport aids during transit.
3. Locations with high ambient temperature, moisture or humidity must be avoided.
  - a) The installation site humidity should be <95% non-condensing.
  - b) The prescribed equipment ambient temperature is 0°C to +40°C.
  - c) A battery temperature of 20°C to 25°C is recommended to achieve a long battery life.
  - d) The air conditioning system must be able to provide a sufficient amount of cooling air to keep the room within the prescribed temperature range.
  - e) The air entering the UPS must not exceed +40°C.
4. To obtain the best system performance the following environmental conditions should also be considered:
  - a) Fire protection standards must be respected.
  - b) The location must be free of dust and corrosive, or explosive, gases.
  - c) The location must be vibration free.
  - d) If the UPS is located in bayed enclosures, partition walls must be installed.
  - e) The minimum cabinet clearances described below must be provided.

### 3.2.2 Installation

The PW 8000DPA RI UPS is of rack/sub-rack construction designed to be installed in a standard 19 inch cabinet. The table below shows the rack height required by each model. We recommend that the UPS is installed at the bottom of the rack cabinet, especial if the UPS assembly includes internal batteries.

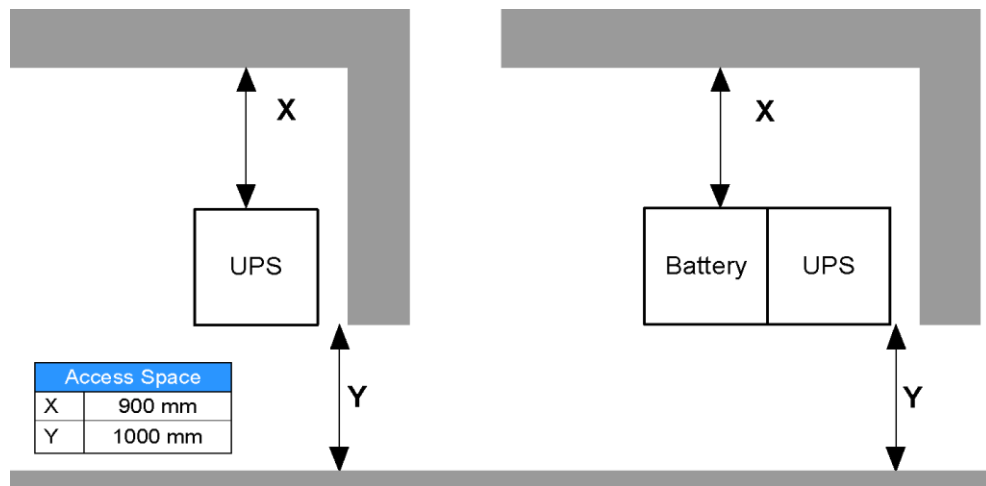
	UPS Rack						
	RI-10	RI-11	R1-12	RI-20	RI-22	RI-24	RI-40
Dimensions (W x H x D) mm	448x310x565 482*x310x565	448x487x735 482*x487x735	448x665x735 482*x665x735	448x440x565 482*x440x565	448x798x735 482*x798x735	448x1153x735 482*x1153x735	448x798x735 482*x798x735
Rack Height	7HU	11HU	15HU	10HU	18HU	26HU	18HU
<i>482* is the width of the UPS rack including the front mounting wings</i>							

#### Internal cabinet clearances

Cooling air enters inlets at the side and bottom of the UPS module(s) and is drawn through the back of the unit by extraction fans that are mounted in the rear of the UPS rack. To provide an adequate cooling air flow through the UPS module(s), the host cabinet must have sufficient internal clearances in front and behind the UPS modules. The minimum required front and back clearance within the host cabinet depends on the cabinet's design, in particular whether or not the cabinet has a fully ventilated front/back door.

	Cabinet with ventilated door	Cabinet with non-ventilated door
Recommended internal front clearance	50 mm	100 mm
Recommended internal rear clearance	50 mm	200 mm

#### External cabinet clearances



**Figure 3.1 Rack cabinet clearance recommendations**

The PW 8000DPA RI UPS sub-rack requires rear access in order to connect the power cables, and we recommend a minimum of 900 mm clearance is provided at the rear of the rack cabinet. A minimum clearance of 1000 mm is required at the front of the rack cabinet to allow the UPS assemblies to be installed and serviced.

If the system includes an external battery it should be installed next to the UPS unit to reduce the voltage drop on the battery cables. The battery cabinet can be located on either side of the UPS but ideally it should be placed to the left of the UPS unit.

Heat dissipation figures are provided in the Specifications chapter of this manual.

### 3.3 Electrical and cabling planning

#### 3.3.1 General requirements

The information in this section should help with the preparation and planning of the UPS power cabling.

**IMPORTANT NOTE:** The UPS does not contain internal fuse protection for the bypass mains or input mains supplies. It is the customer's responsibility to ensure that external supply fuses (or other protective devices) are fitted and correctly sized to provide the recommended level of UPS protection. We also recommend that a spare set of fuses are held locally to ensure they are readily available if required.

The UPS bypass mains and input mains terminals should be connected to the utility mains supply through a LV mains switchboard that contains suitable circuit breakers or fused isolators. These are necessary to provide a means of isolating the UPS from the mains supplies when required and provide suitable overload protection. Similarly, the UPS output supply terminals should be connected to the load equipment via a fused output distribution panel.

#### Input neutral grounding

A permanently connected input neutral is required to enable the rectifier to operate correctly and allow the UPS to function properly.

The input neutral must also be grounded to ensure correct operation when the UPS is running on battery.

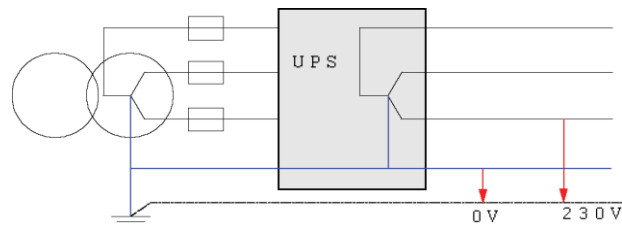


Figure 3.2 Input neutral grounding



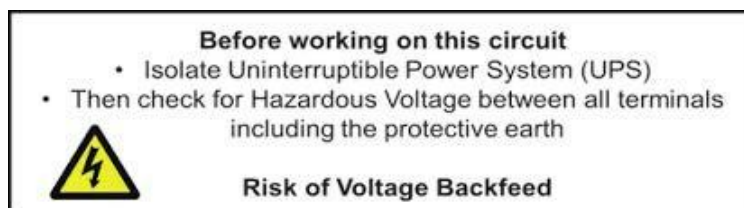
**Key Point:** As the input neutral must be unswitched and connected to the UPS at all times, a 4-pole input switch or isolator must not be used at the LV switchboard on a TN-S system.

#### External Backfeed protection

A UPS shall prevent hazardous voltage or hazardous energy from being present on the UPS input AC distribution after interruption of the input AC power. This is achieved by mandatory backfeed protection. Unless optional internal protection is included in UPS frame, such protection shall be provided by others and be installed as part of building installation. The backfeed protection shall be implemented in the form of an air gap, separating the upstream circuit from UPS when AC input fails. This is typically achieved through a contactor installed over the common AC input line or over each separate AC input line. Preferred location is just after the overcurrent protective devices serving each UPS input line. Such contactors shall have the coil supplied by the AC upstream circuit, to be engaged when AC upstream voltage is ON or dis-engaged when AC upstream voltage is OFF.

Specifications:

The device shall be three-poles, creating an air gap of at least 3 mm. The thermal current shall meet the external overcurrent protection's rating described in the coming sections. Electrical contractor is required to attach following "Voltage backfeed warning label" as close as possible to the external isolator:



### 3.3.2 Cable and fuse sizing



**Key Point:** All external fuses, isolators and power cables must be rated and installed in accordance with the prescribed IEC standards or local regulation – e.g. BS7671.

Note: Terminal block connection details are provided on pages 45.

#### Input/bypass mains supply cables

The UPS cabinet can be wired for a 'single feed' or 'dual feed' (split bypass) mains supply.

In a 'single feed' system (standard) the UPS input mains and bypass mains terminals are linked within the UPS cabinet, but in a 'dual feed' system the links are removed and the bypass mains terminals are connected to a dedicated bypass mains supply. The two configurations are shown in Figure 3.3.

The input supply and bypass supply neutrals are connected to a common neutral busbar. If the input mains and bypass mains are obtained from the same AC power source in a 'dual feed' system it is permissible to connect just one neutral cable.

All input mains and bypass mains cables should be connected through a LV mains switchboard and protected by circuit breakers or fuses to provide overload protection and a means of isolating the UPS from the mains supply when required.

Note: We recommend that the input cables are sized for the full frame rating in a parallel module frame even if some UPS modules are not initially installed. This will allow the system to be expanded to its full rating without having to shut it down to up-rate the input cables.

For example: the cables connected to the PW 8000DPA RI 40 frame should be rated for the full 80 kW load even if fewer than four UPS modules are fitted.

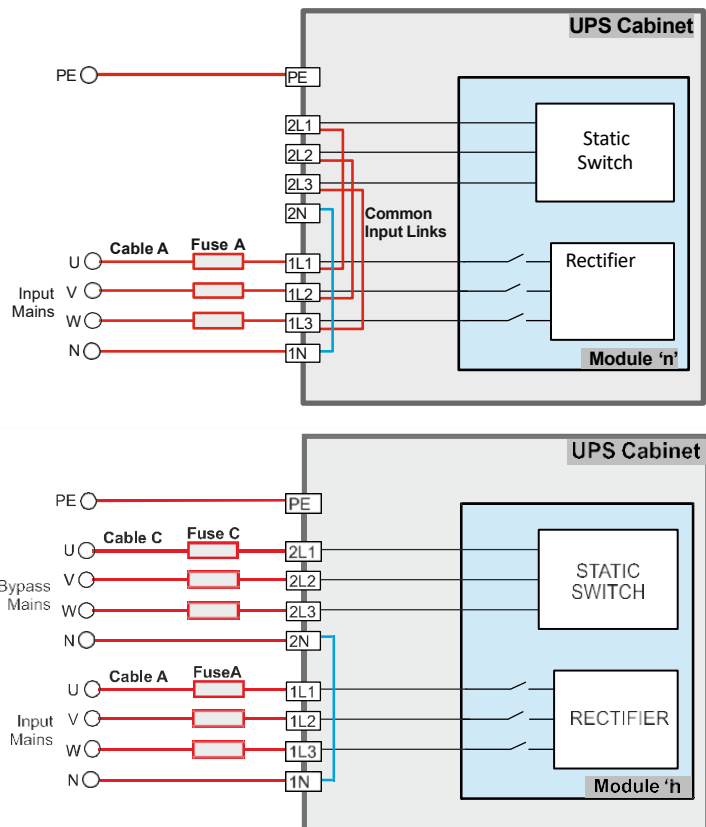


Figure 3.3 Single and dual feed input configuration

### UPS Output cables

The UPS output cables should be connected to the load equipment via a suitably fused output distribution panel.

*Note: We recommend that the output cables are sized for the full frame rating in a parallel module frame even if some UPS modules are not initially installed. This will allow the system to be expanded to its full rating without having to shut it down to up-rate the output cables.*

*For example: the output cables connected to the PW 8000DPA RI 40 frame should be rated for the full 80 kW load even if fewer than four UPS modules are fitted.*

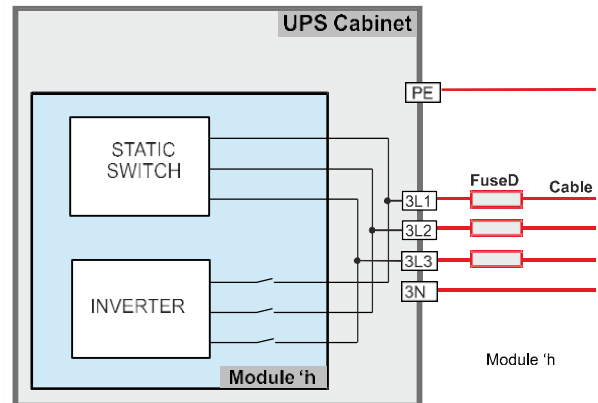


Figure 3.4 UPS Output cables

## Battery cables

### Internal batteries

The batteries in PW 8000DPA RI models RI-11, RI-12, RI-22, RI-24 are installed on shelves that form part of the UPS frame and are therefore described as being 'internal.' Each shelf contains a complete battery string which is connected to a UPS module via a battery breaker (F4-x).

Note that in the RI-12 and RI-24 models there are two rows of battery trays provided for each UPS module. In these models two battery strings can be connected in parallel at the module battery breaker to provide a greater autonomy time (battery run-time) than that which is available from a single battery string.



**Key Point:** PW 8000DPA RI frames that contain internal batteries are shipped without the batteries installed.

### External batteries

PW 8000DPA RI models RI-10, RI-20, RI-40 do not have provision for internal batteries and therefore require the batteries to be installed in an external enclosure. External batteries are installed in a purpose designed enclosure or battery cabinet that should be located as close as possible to the UPS rack. A range of external battery enclosures is available from Rehiko.

When planning for an external battery installation please consider the following:

- The external battery must be installed as close as possible (ideally on the left side) to the UPS equipment rack.
- We recommend that when dealing with a parallel UPS frame a separate battery is provided for each UPS module. (See 'common' / 'separate' battery configuration details below.)
- If a bespoke battery installation is planned, it must include a 3-pole battery breaker (for each set of battery cables) installed as close as possible to the battery installation.
- The battery and DC cables must be connected by the commissioning engineer.
- The battery cables and fuses are bespoke to the installation and will be provided by Rehiko but it is the customer's responsibility to install any cable containment where necessary. *Note that the external battery string connection requires three cables, one each connected to the battery positive (+) and negative (-) extremities and a third (N) cable that is connected to the mid-point of the battery string.*

### Common battery configuration

A 'common battery' installation is shown in Figures 3.5 and 3.7.

In this configuration a single external battery, which can itself comprise several parallel battery strings, is connected to the battery terminals (+, N, -) within the UPS cabinet from where it is connected to the UPS modules via dedicated circuit breakers (F4-x).

Following a mains outage, if there is a total battery failure in a 'common battery' system the entire UPS is unable to operate from battery power, resulting in the loss of the critical load supply. However, the battery normally consists of several parallel battery strings, and a battery failure in one string only means that the UPS will operate on battery power as normal but with a much reduced autonomy.

### Separate battery configuration

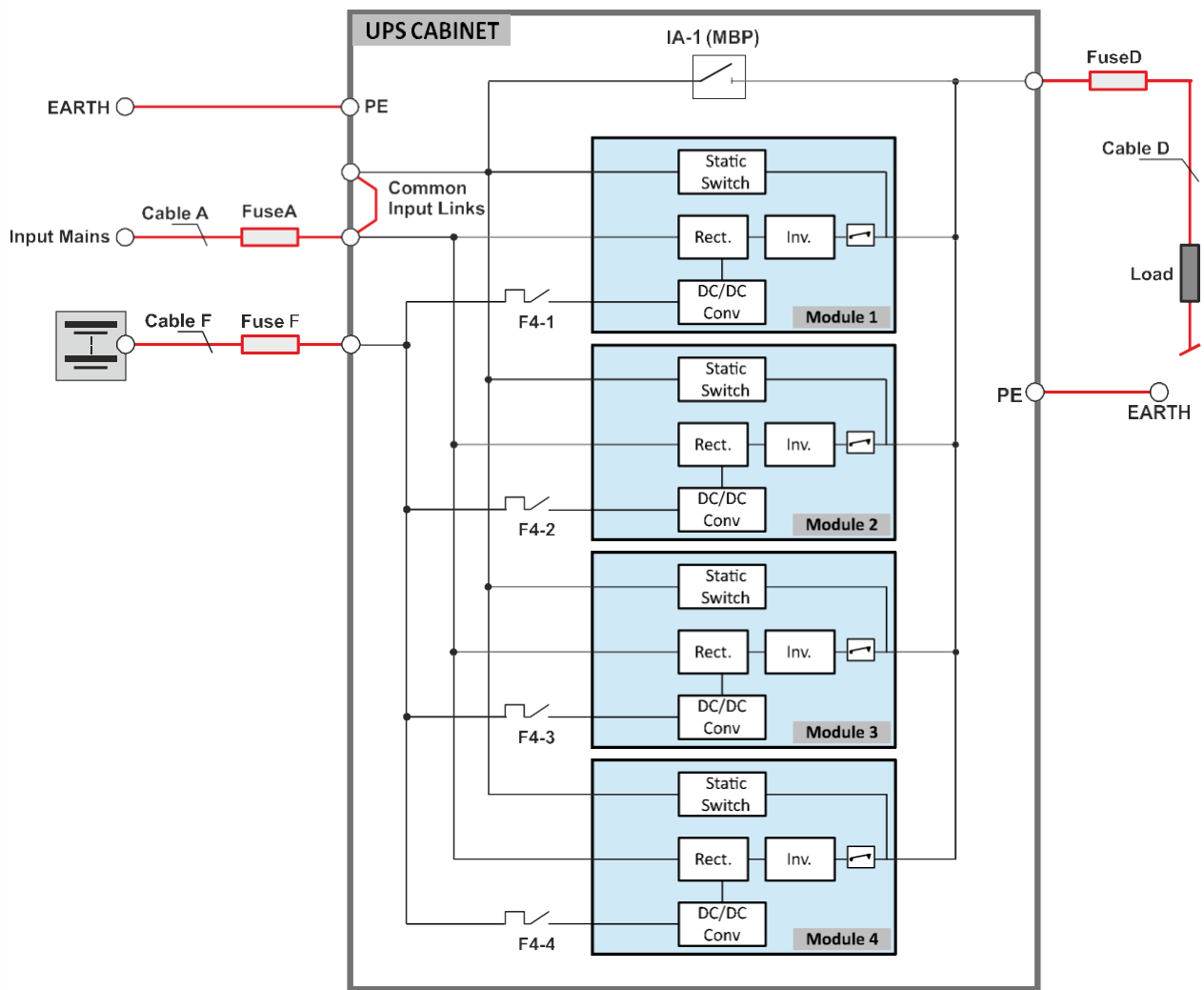
A 'separate battery' configuration enhances the overall reliability/availability of the UPS system by providing a degree of battery redundancy – i.e. following a mains outage, the total failure of a battery only affects its associated module and the remainder of the UPS system can fully support the critical load – assuming n+1 module redundancy.

A 'separate battery' installation is shown in Figures 3.6 and 3.8 for a single-feed input and dual-feed input respectively. In these illustrations each battery is connected directly to the module circuit breakers (F4-x) and not to the main battery busbars (+ve & -ve).

### Cabling diagrams

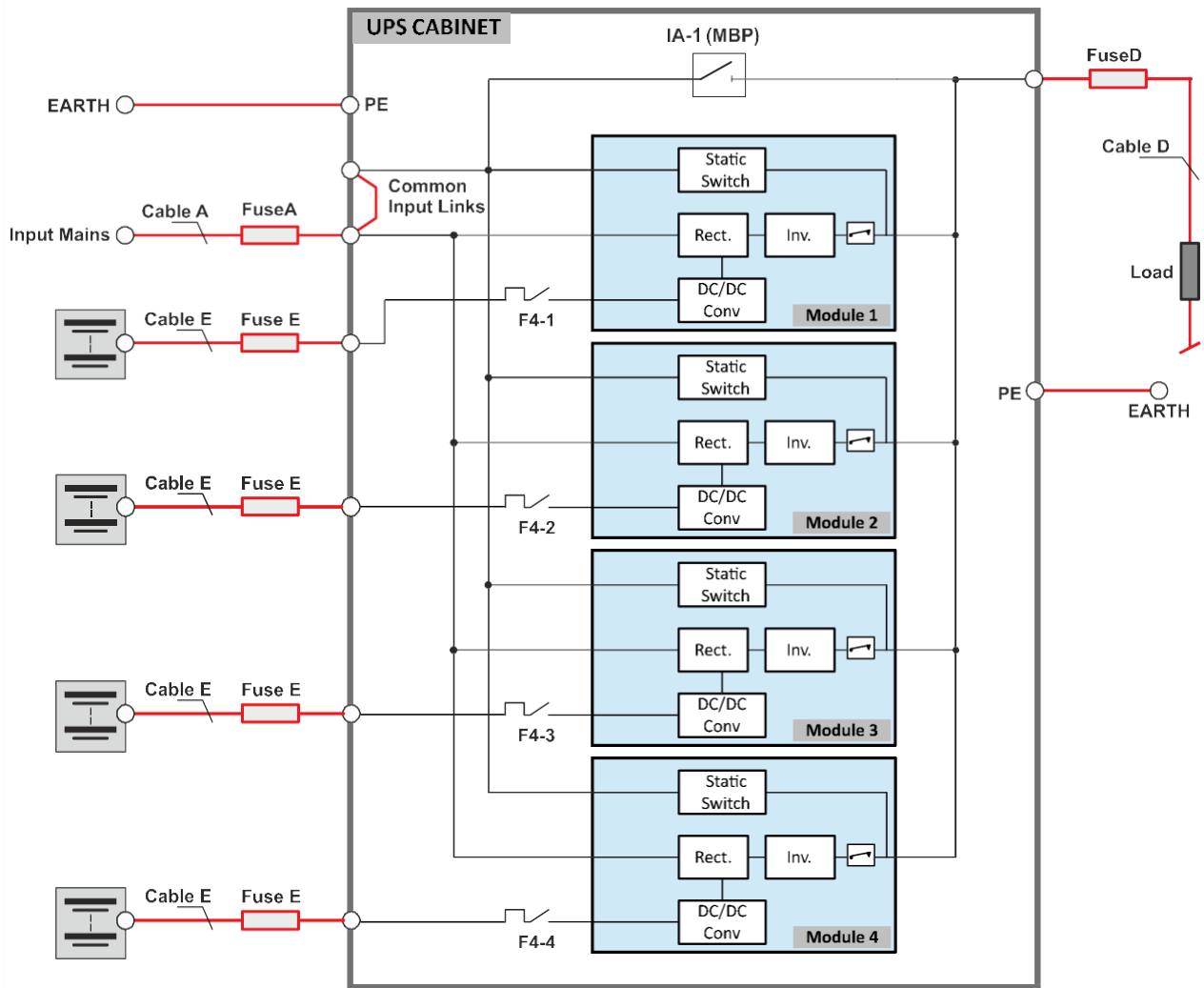
The following diagrams provide recommended cable and fuse rating for the entire PW 8000DPA RI range.

- The protective earth cable must be sized according to local and national regulations
- Rating are shown for 400V operation with unity load factor. See specification chapter for 380/415V operation.



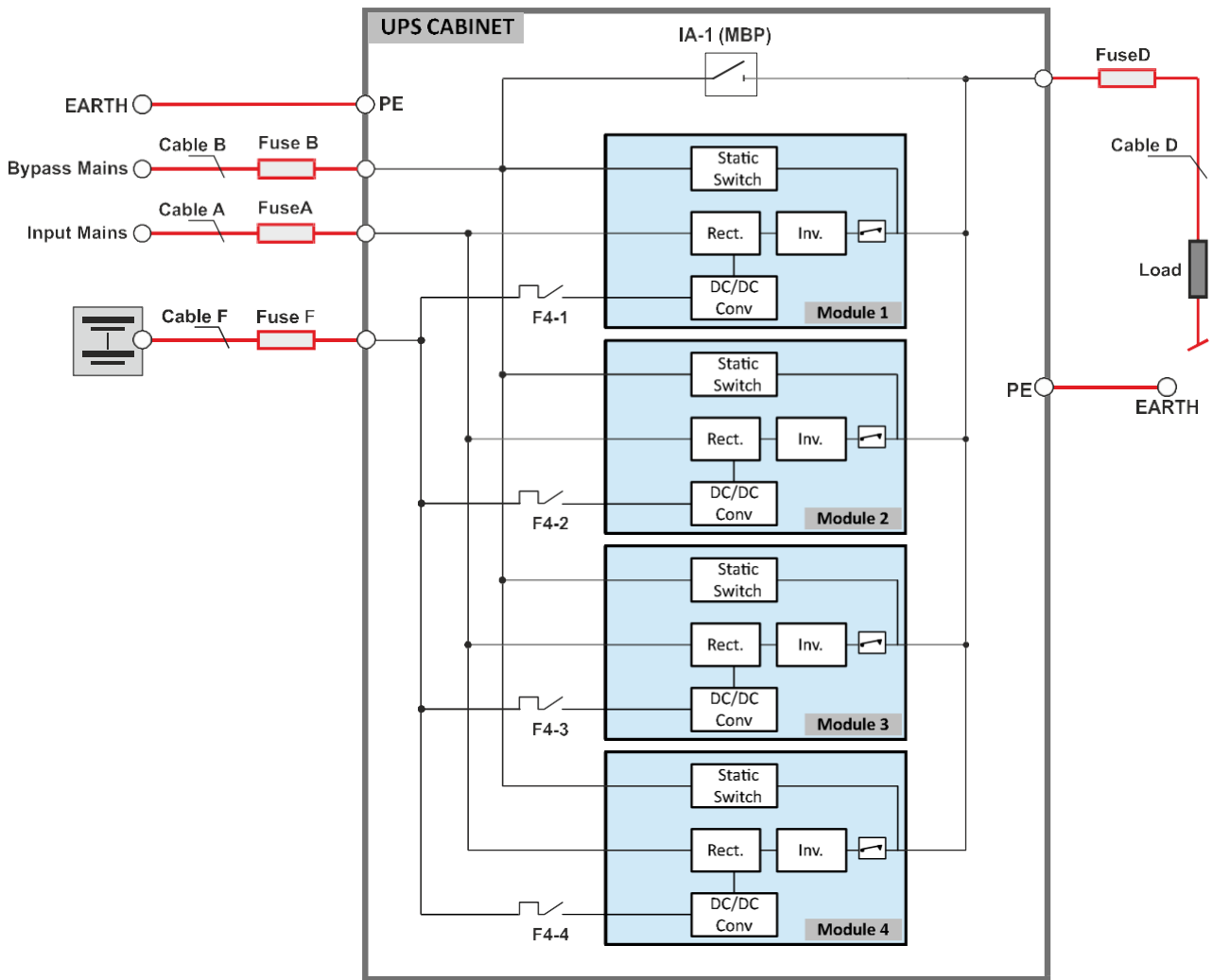
UPS CABINET CONNECTIONS							
UPS Model (fully populated)	RI-10	RI-11	RI-12	RI-20	RI-22	RI-24	RI-40
Load (kW)	20 kW	20 kW	20 kW	40 kW	40 kW	40 kW	80 kW
Fuse A (Agl/CB)	3x 40A	3x 40A	3x 40A	3x 80A	3x 80A	3x 80A	3x 160A
Max input current, battery charging (A)	34A	34A	34A	68A	68A	68A	136A
Nominal output current	29A	29A	29A	58A	58A	58A	116A

Figure 3.5 Single input cabling with common battery



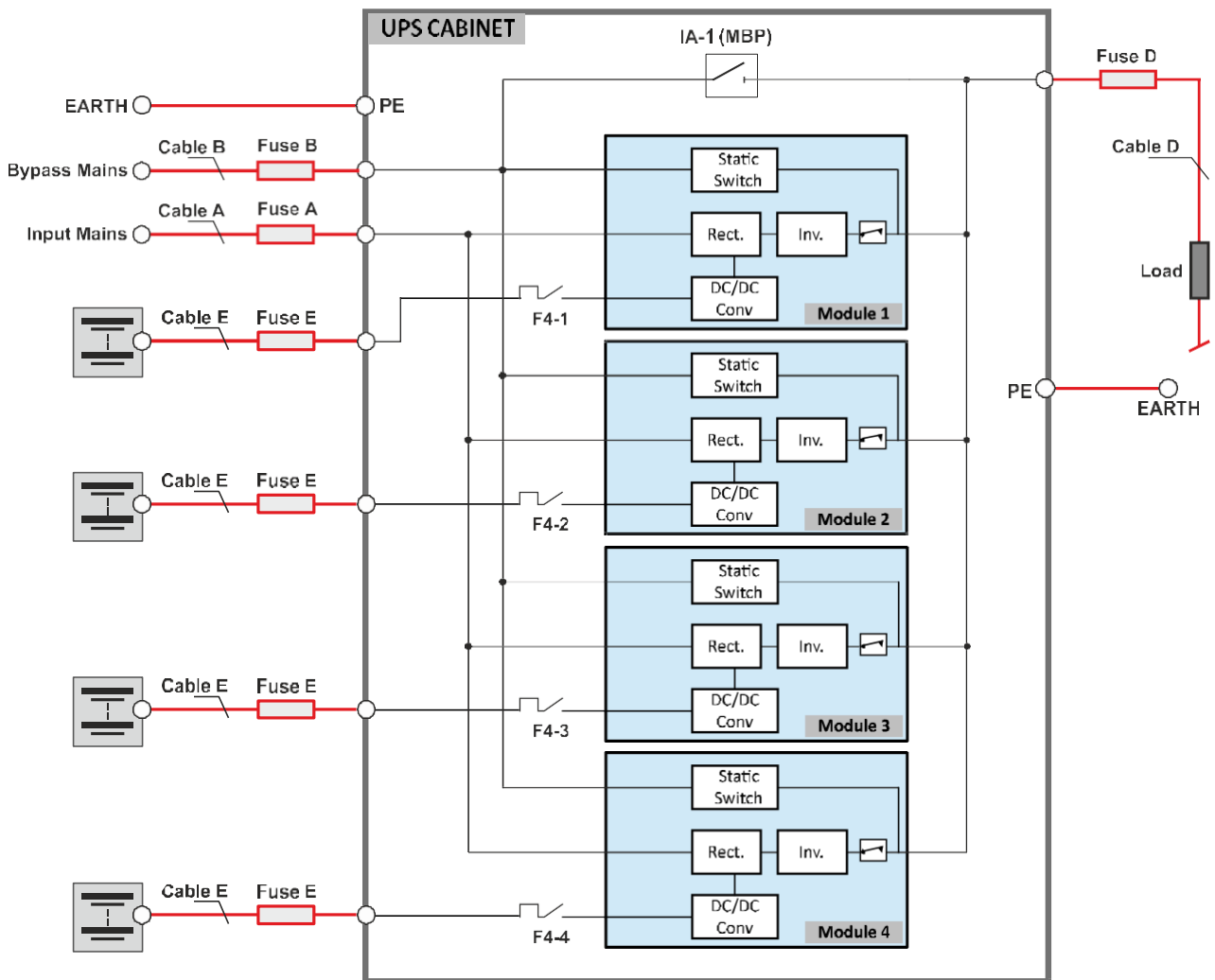
UPS CABINET CONNECTIONS							
UPS Model (fully populated)	RI-10	RI-11	RI-12	RI-20	RI-22	RI-24	RI-40
Load (kW)	20 kW	20 kW	20 kW	40 kW	40 kW	40 kW	80 kW
Fuse A (Agl/CB)	3x 40A	3x 40A	3x 40A	3x 80A	3x 80A	3x 80A	3x 160A
Max input current, battery charging (A)	34A	34A	34A	68A	68A	68A	136A
Nominal output current	29A	29A	29A	58A	58A	58A	116A

Figure 3.6 Single input cabling with separate batteries



UPS CABINET CONNECTIONS							
UPS Model (fully populated)	RI-10	RI-11	RI-12	RI-20	RI-22	RI-24	RI-40
Load (kW)	20 kW	20 kW	20 kW	40 kW	40 kW	40 kW	80 kW
Fuse A (Agl/CB)	3x 40A	3x 40A	3x 40A	3x 80A	3x 80A	3x 80A	3x 160A
Max input current, battery charging (A)	34A	34A	34A	68A	68A	68A	136A
Nominal output current	29A	29A	29A	58A	58A	58A	116A

Figure 3.7 Dual input cabling with common battery



UPS CABINET CONNECTIONS							
UPS Model (fully populated)	RI-10	RI-11	RI-12	RI-20	RI-22	RI-24	RI-40
Load (kW)	20 kW	20 kW	20 kW	40 kW	40 kW	40 kW	80 kW
Fuse A (Agl/CB)	3x 40A	3x 40A	3x 40A	3x 80A	3x 80A	3x 80A	3x 160A
Max input current, battery charging	34A	34A	34A	68A	68A	68A	136A
Nominal output current	29A	29A	29A	58A	58A	58A	116A

Figure 3.8 Dual input cabling with separate batteries

### 3.4 External maintenance bypass

Operationally, an external maintenance bypass facility is not essential. The internal maintenance bypass switch (IA1) is fully rated and can be used to connect the UPS output directly to the bypass mains supply if the UPS modules are unavailable. However, when the load is powered via IA1 the UPS frame bypass mains terminals must be permanently live in order to power the load. This means that it is not possible to fully isolate the mains supplies from the UPS frame while the internal maintenance bypass is in use.

This situation can be overcome by the addition of an optional external maintenance bypass facility which can supply the load through an external 'bypass' switch while allowing the UPS input and output supplies to be totally isolated.

An external maintenance bypass facility is bespoke but generally comprises three isolators rated to carry the full system load and connected in a similar fashion to that shown in Figure 3.9.

*Note: A fourth isolator may be included if the UPS is configured for a dual input supply.*

Depending on size and location, the isolators may be installed in a dedicated maintenance bypass cabinet or included in an existing (or dedicated) switch panel.

Rehlko can provide a range of external maintenance bypass solutions to suit all of its UPS systems.

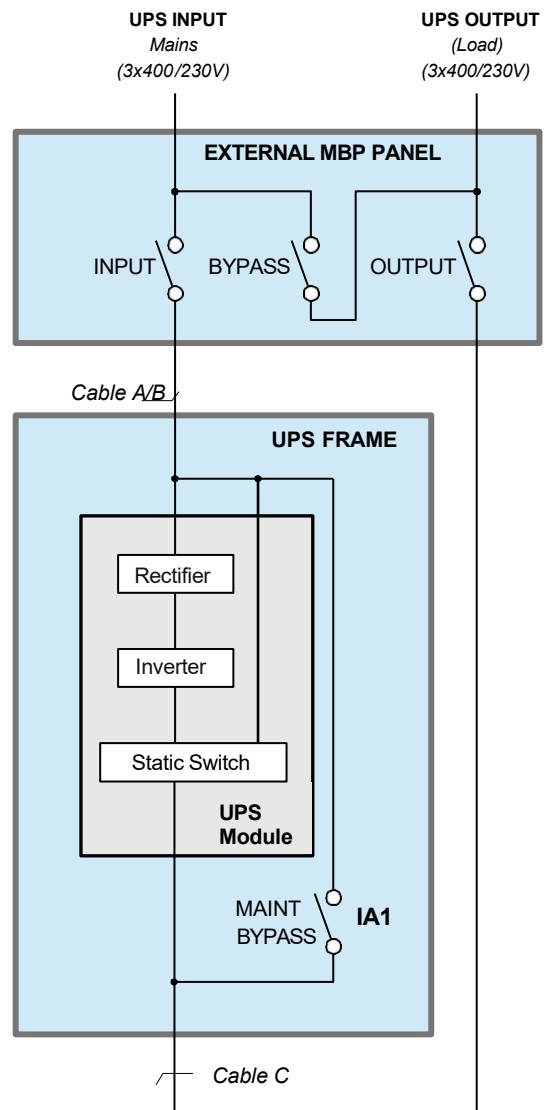


Figure 3.9 External Maintenance Bypass

# 4. Installation Procedure

## 4.1 Introduction

This chapter contains essential information concerning the unpacking, positioning, mechanical installation and cabling of the PW 8000DPA RI (S2) UPS.



**WARNING:** All cabling operations must be supervised by an authorised electrician or other suitably qualified person. All installation procedures must be carried out in strict accordance with the instructions contained in this manual. Rehiko will take no responsibility for any personal injury or material damage caused by the incorrect installation, cabling or operation of this product.



**WARNING:** Once the UPS equipment is installed it must be commissioned by an engineer approved by Rehiko before it is powered-up. Rehiko will take no responsibility for any personal injury or material damage caused by the application of electrical power to this equipment before it has been fully commissioned and handed over to the customer.

## 4.2 Taking receipt of the UPS

The UPS frame and accessories are delivered on purpose designed pallets that are easy to off load and move using a forklift or suitable pallet jack.



**CAUTION:** Observe the following precautions when off-loading and moving the UPS:

- Always keep the packages in an upright position.
- Do not drop the equipment.
- Due to the high-energy batteries involved and heavy weight, do not stack the pallets.

Depending on the shipping method, the UPS is packed in a cardboard or wooden container designed to protect it from mechanical and environmental damage. Further protection is provided by wrapping the equipment with a plastic sheet.

Before you accept the shipment you should ensure that the received package(s) correspond to the description shown in the delivery documentation. Note that some ordered optional equipment packages might be shipped inside the UPS package.

Upon receiving the UPS you should carefully examine the

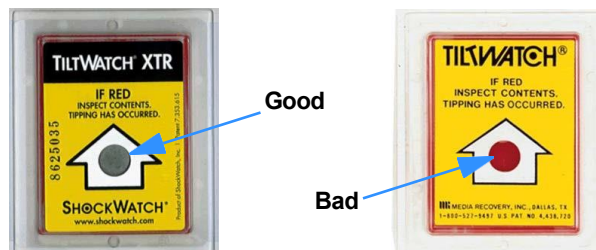


Figure 4.1 Tiltwatch indicators

packing container for any sign of physical damage. External 'TiltWatch' indicators (2 off) will indicate RED if the equipment has been tilted during transportation.

### 4.2.1 Reporting transportation damage



**WARNING:** If the TiltWatch indicators indicate that the UPS has been tilted in transit DO NOT connect the UPS to the mains electricity supply.

If the 'TiltWatch' indicators are red or there are other signs of suspected transportation damage you must inform both the carrier and Rehiko immediately.

Claims for shipping damage must be filed immediately when found, and the carrier must be informed of ALL claims within seven days of receipt of the equipment. If the equipment is to be stored for longer than seven days before it is installed, you should unpack it and inspect it for signs of internal damage before you put it into storage. Note that some optional equipment packages might be shipped inside the UPS package and these too should be inspected.

If the equipment is damaged you should store the packing materials for further investigation.

## 4.2.2 Local transportation

Please observe the following precautions when you transport the UPS equipment after it has been off-loaded.



**CAUTION:** Local transportation:

- When moving the UPS cabinet using a forklift or pallet jack, insert the lifting equipment forks below the package and ensure they support both front and back of the packed equipment.
- Do not at any time tilt the cabinet by more than 10° from vertical as it could cause internal damage.



**WARNING:** Potential dangers:

- If tilting occurs at any stage do not connect the UPS to the mains electrical supply.
- The cabinet weight can cause serious personal injury and/or structural damage to the surrounding area if it is dropped in transit. Always take extreme care when moving the equipment.

## 4.2.3 Storage

### UPS Cabinet

If you plan to store the UPS equipment prior to use it should be held in a clean, dry environment with a temperature between -25°C to +70°C and RH <95% (non condensing). An ideal storage temperature is between +20°C to +25°C.

The UPS should be stored in its original packing and shipping carton. If the packing container is removed you must take measures to protect the UPS from the ingress of dust and moisture.

### Battery

The UPS uses sealed, maintenance-free batteries whose storage capacity depends on the ambient temperature. It is important not to store the batteries for longer than 6 months at 20°C, 3 months at 30°C, or 2 months at 35°C storage temperature without fully recharging them.

For longer term storage the batteries should be fully recharged every 6 months @20°C.

An storage temperature between +20°C to +25°C will help achieve optimum battery life.



**CAUTION:** Sealed batteries must never be stored in a fully or partially discharged state. Extreme temperature, under-charge, overcharge or over-discharge will destroy batteries!

- Charge the battery both before and after storing.
- Always store the batteries in a dry, clean, cool environment in their original packaging.
- If the packaging is removed protect the batteries from dust and humidity.

## 4.3 Unpacking



**Key Point:** Remove all packaging materials carefully, causing as little damage as possible, and temporarily store them in case the UPS has to be returned to the manufacturer for any reason prior to commissioning.

### Removing the standard UPS packaging



**Figure 4.2**

1. Cut and remove the two sealing bands (A) that are wrapped around the cardboard packing container cover.
2. Carefully open the top of the cardboard packing container (B) and remove any accessories (C) that are shipped in the top of the package – e.g. User Manual, rack mounting hardware.
3. Remove the cardboard packing container by lifting it upwards.
4. Remove the plastic wrap and corner protection fillets (D).
5. Remove the four bolts (E) that are used to secure each UPS pallet mounting then separate the UPS from the pallet.



**WARNING:** The UPS should be supported on the trolley jack while the shipping pallet is removed.

6. Carry out a thorough inspection and report any damage to the shipper immediately. If there are no signs of damage the UPS can be transported to its intended installation location in readiness to be installed.

### Removing the alternative wooden crate packaging

1. Cut and remove the two sealing bands that are wrapped around the wooden crate.
2. Remove the wooden crate sides and top by removing the securing screws from the bottom and sides of each panel
3. Carefully lift away the wooden crate and remove any accessories (C) that are shipped in the top of the package – e.g. User Manual, rack mounting hardware.
4. Remove the plastic wrap and corner protection fillets (D).
5. Undo the four bolts that are securing the UPS to the pallet then remove the UPS from the pallet.
6. Remove the four bolts (E) that are used to secure each UPS pallet mounting then separate the UPS from the pallet.



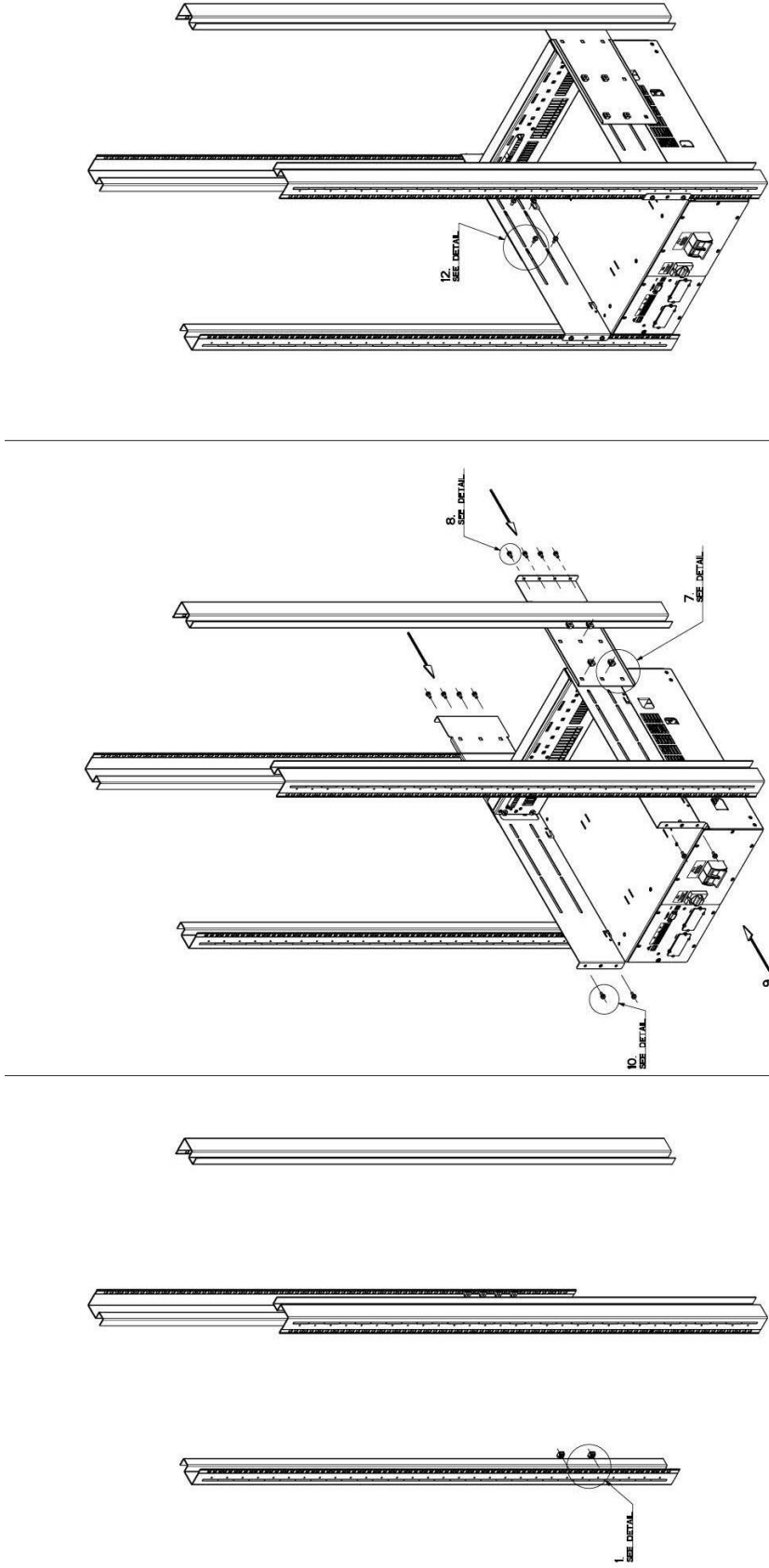
**WARNING:** The UPS should be supported on the trolley jack while the shipping pallet is removed.

## 4.4 Mechanical installation

The PW 8000DPA RI (S2) UPS is of rack/sub-rack construction designed to be installed in a standard 19 inch rack cabinet.

Usually, the racks used to house this equipment come fully assembled and ready for the modules to be inserted. However, if this is not the case then the rack system must be assembled as illustrated in Figures 0.1 to 0.1.

1. Once the UPS rack is fully assembled fit it to the rack cabinet and secure it in place.



DETAIL 1 SCALE 1:2		NOT SUPPLIED
DETAIL 7 SCALE 1:2		SUPPLIED
DETAIL 8 SCALE 1:2		NOT SUPPLIED
DETAIL 10 SCALE 1:2		NOT SUPPLIED
DETAIL 12 SCALE 1:2		SUPPLIED

Figure 0.1 RI-10 (Type X1)

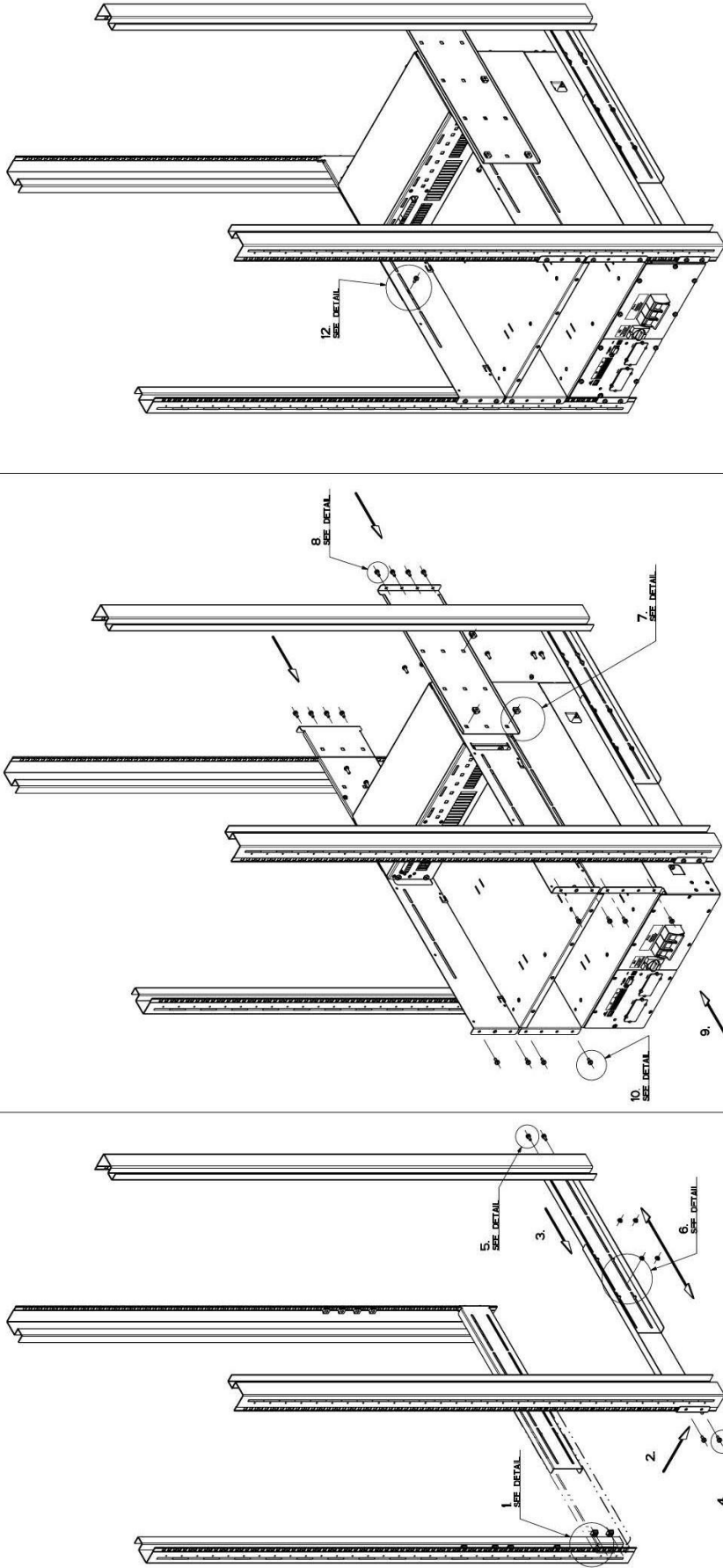
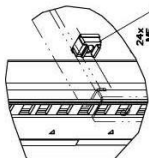


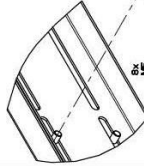
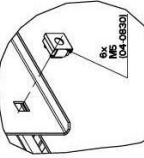

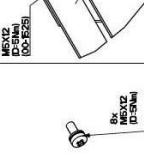






Figure 0.1 RI-11 (Type 1)

DETAIL SCALE 1:2	DETAIL SCALE 1:2	DETAIL SCALE 1:2	DETAIL SCALE 1:2	DETAIL SCALE 1:2	DETAIL SCALE 1:2	DETAIL SCALE 1:2	DETAIL SCALE 1:2	DETAIL SCALE 1:2	DETAIL SCALE 1:2	DETAIL SCALE 1:2
										
NOT SUPPLIED	NOT SUPPLIED	NOT SUPPLIED	SUPPLIED	SUPPLIED	NOT SUPPLIED	NOT SUPPLIED	NOT SUPPLIED	NOT SUPPLIED	NOT SUPPLIED	SUPPLIED

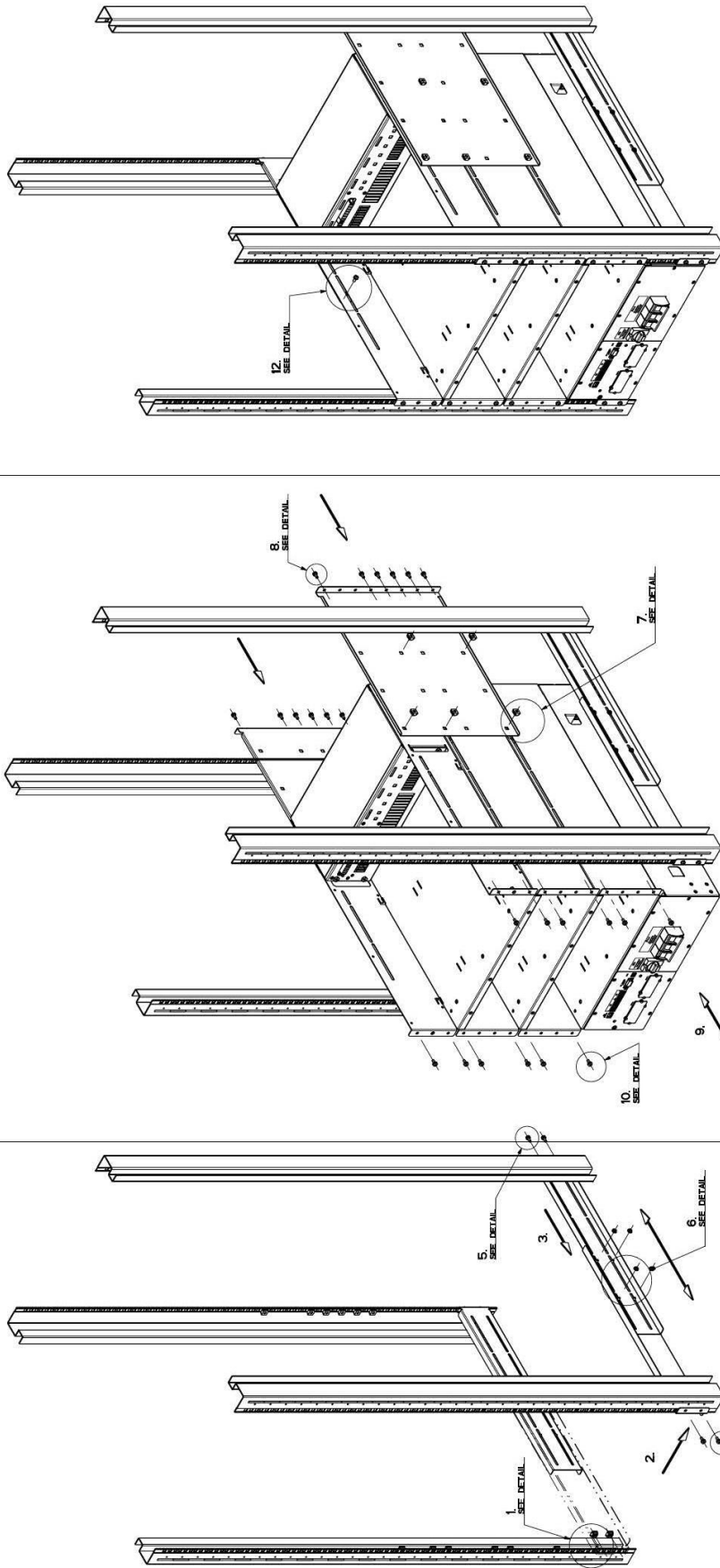
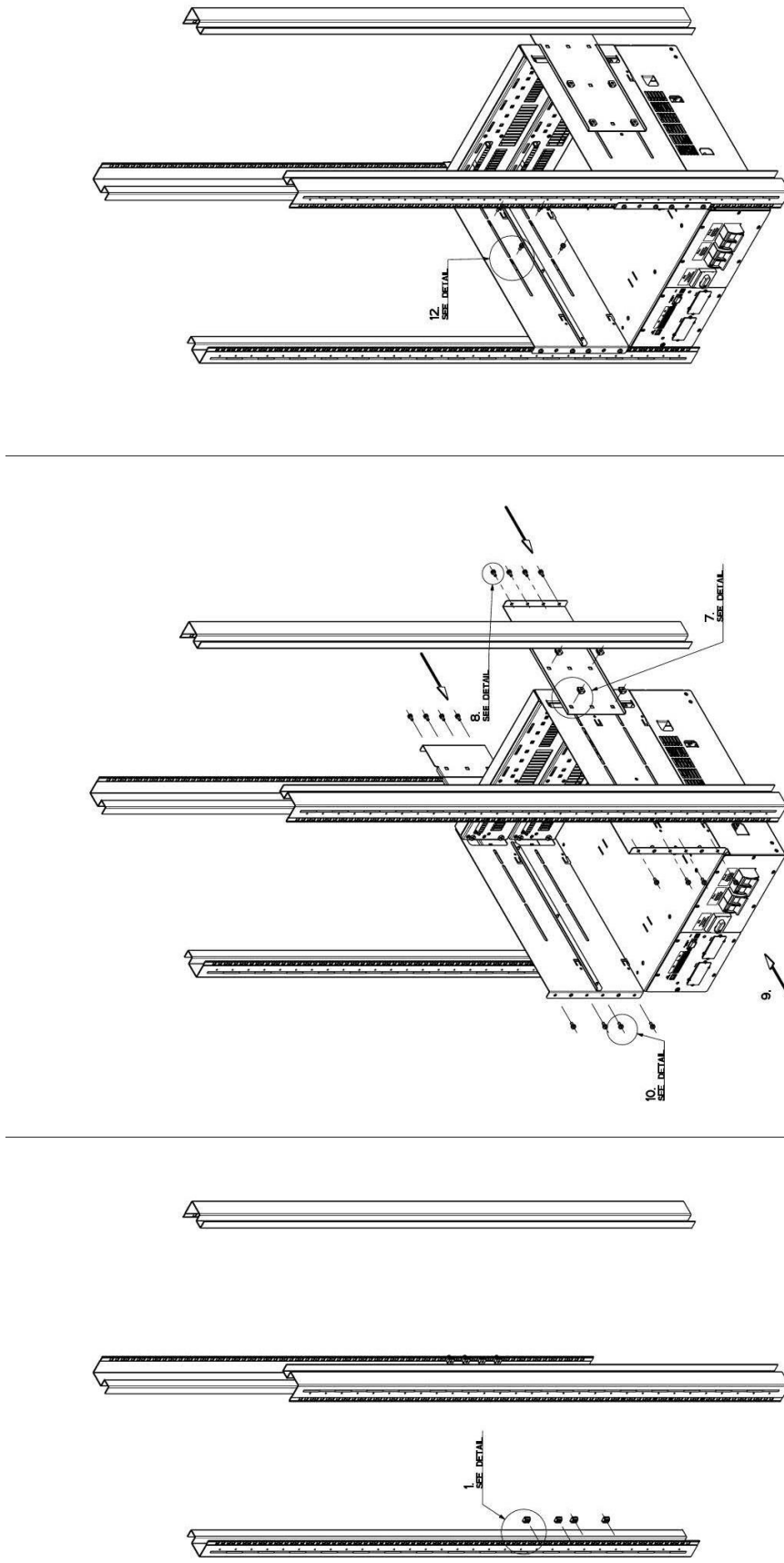


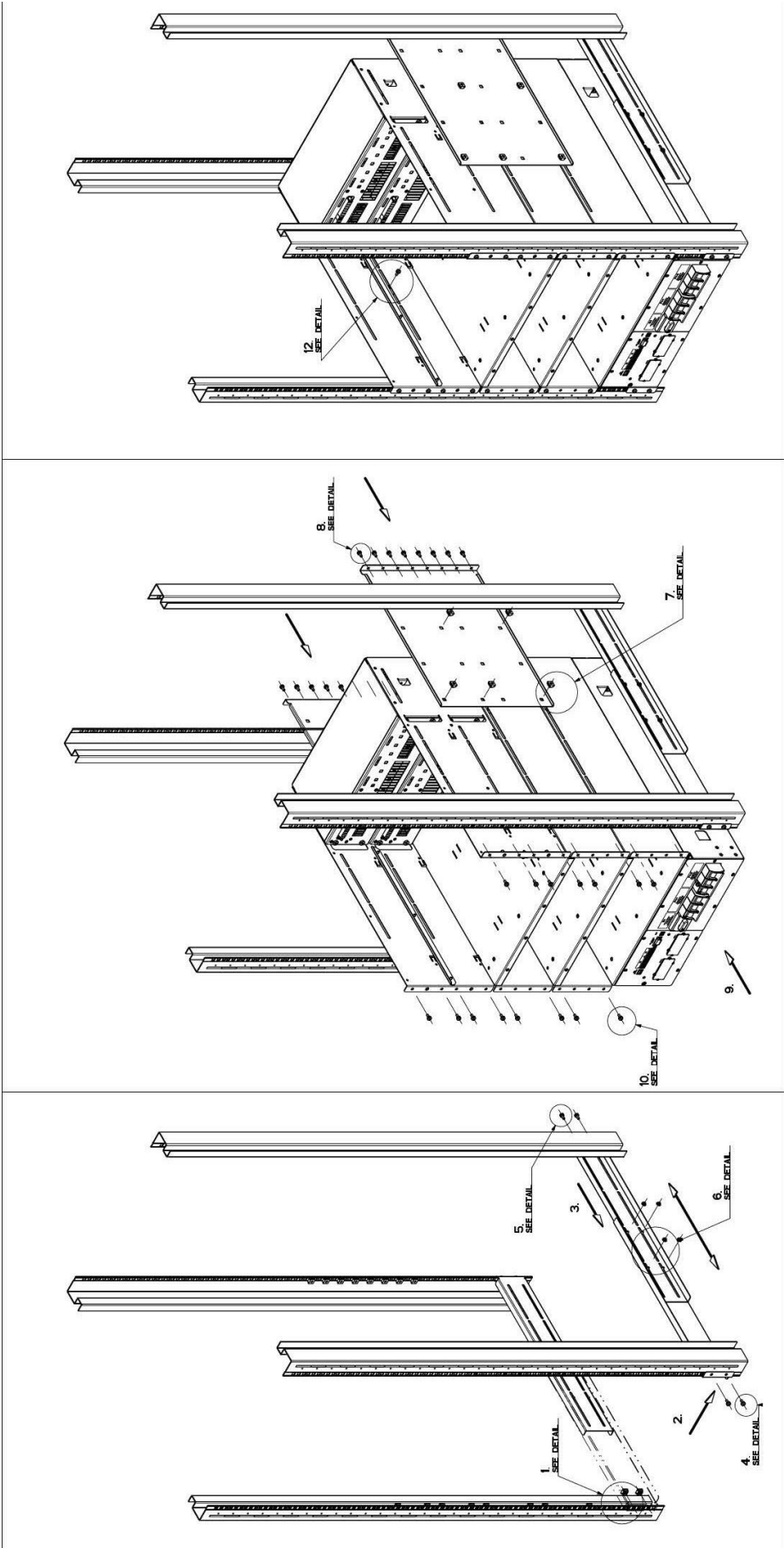
Figure 0.1 RI-12 (Type 2)

DETAIL SCALE 1:2		DETAIL SCALE 1:2		DETAIL SCALE 1:2	
NOT SUPPLIED	NOT SUPPLIED	NOT SUPPLIED	SUPPLIED	NOT SUPPLIED	SUPPLIED
DETAIL SCALE 1:2		DETAIL SCALE 1:2		DETAIL SCALE 1:2	
NOT SUPPLIED	NOT SUPPLIED	NOT SUPPLIED	NOT SUPPLIED	NOT SUPPLIED	NOT SUPPLIED
DETAIL SCALE 1:2		DETAIL SCALE 1:2		DETAIL SCALE 1:2	
NOT SUPPLIED	NOT SUPPLIED	NOT SUPPLIED	NOT SUPPLIED	NOT SUPPLIED	NOT SUPPLIED
DETAIL SCALE 1:2		DETAIL SCALE 1:2		DETAIL SCALE 1:2	
NOT SUPPLIED	NOT SUPPLIED	NOT SUPPLIED	NOT SUPPLIED	NOT SUPPLIED	NOT SUPPLIED
DETAIL SCALE 1:2		DETAIL SCALE 1:2		DETAIL SCALE 1:2	
NOT SUPPLIED	NOT SUPPLIED	NOT SUPPLIED	SUPPLIED	NOT SUPPLIED	SUPPLIED
DETAIL SCALE 1:2		DETAIL SCALE 1:2		DETAIL SCALE 1:2	
SUPPLIED	SUPPLIED	NOT SUPPLIED	NOT SUPPLIED	NOT SUPPLIED	NOT SUPPLIED



DETAIL SCALE 1/2		DETAIL SCALE 1/2		SUPPLIED
		DETAIL SCALE 1/2		SUPPLIED
		DETAIL SCALE 1/2		NOT SUPPLIED
		DETAIL SCALE 1/2		NOT SUPPLIED
		DETAIL SCALE 1/2		NOT SUPPLIED
		DETAIL SCALE 1/2		SUPPLIED

Figure 0.1 RI-20 (Type x2)



DETAIL 1 SCALE 1:2		NOT SUPPLIED
DETAIL 4 SCALE 1:2		NOT SUPPLIED
DETAIL 5 SCALE 1:2		NOT SUPPLIED
DETAIL 6 SCALE 1:2		SUPPLIED
DETAIL 7 SCALE 1:2		SUPPLIED
DETAIL 8 SCALE 1:2		NOT SUPPLIED
DETAIL 10 SCALE 1:2		NOT SUPPLIED
DETAIL 12 SCALE 1:2		SUPPLIED

Figure 0.1 RI-22 (Type 3)

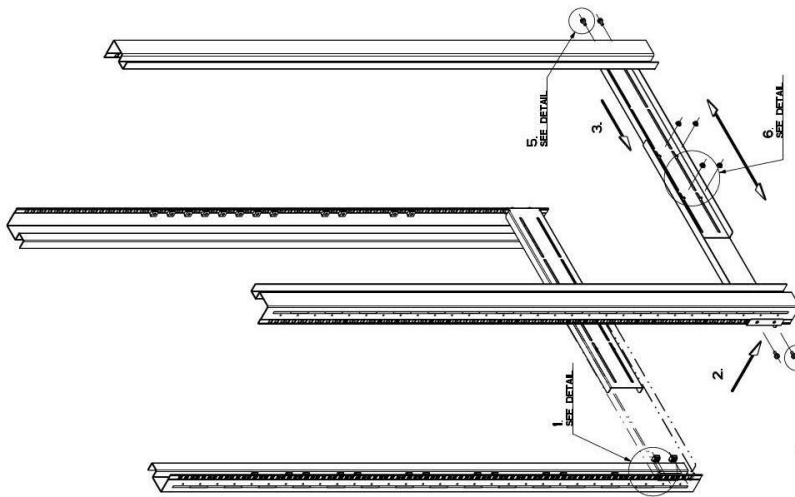
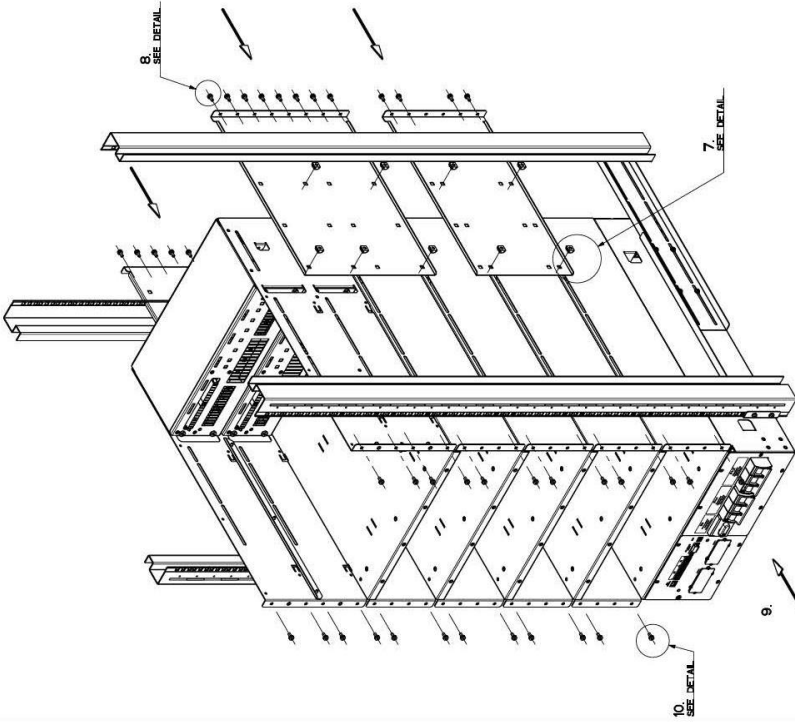
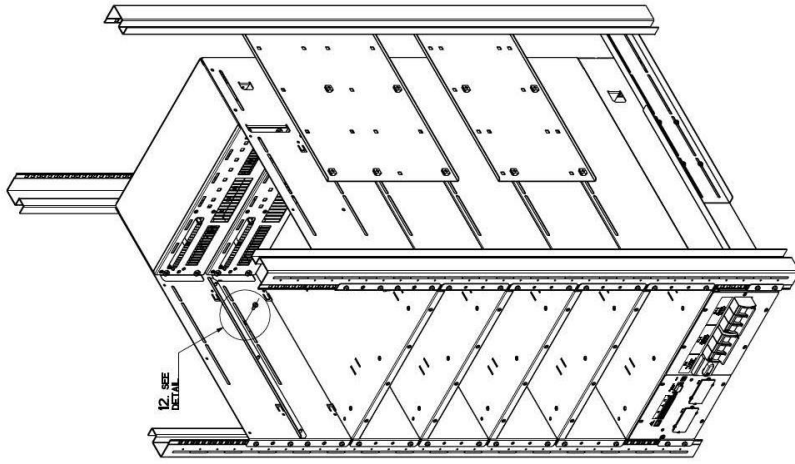
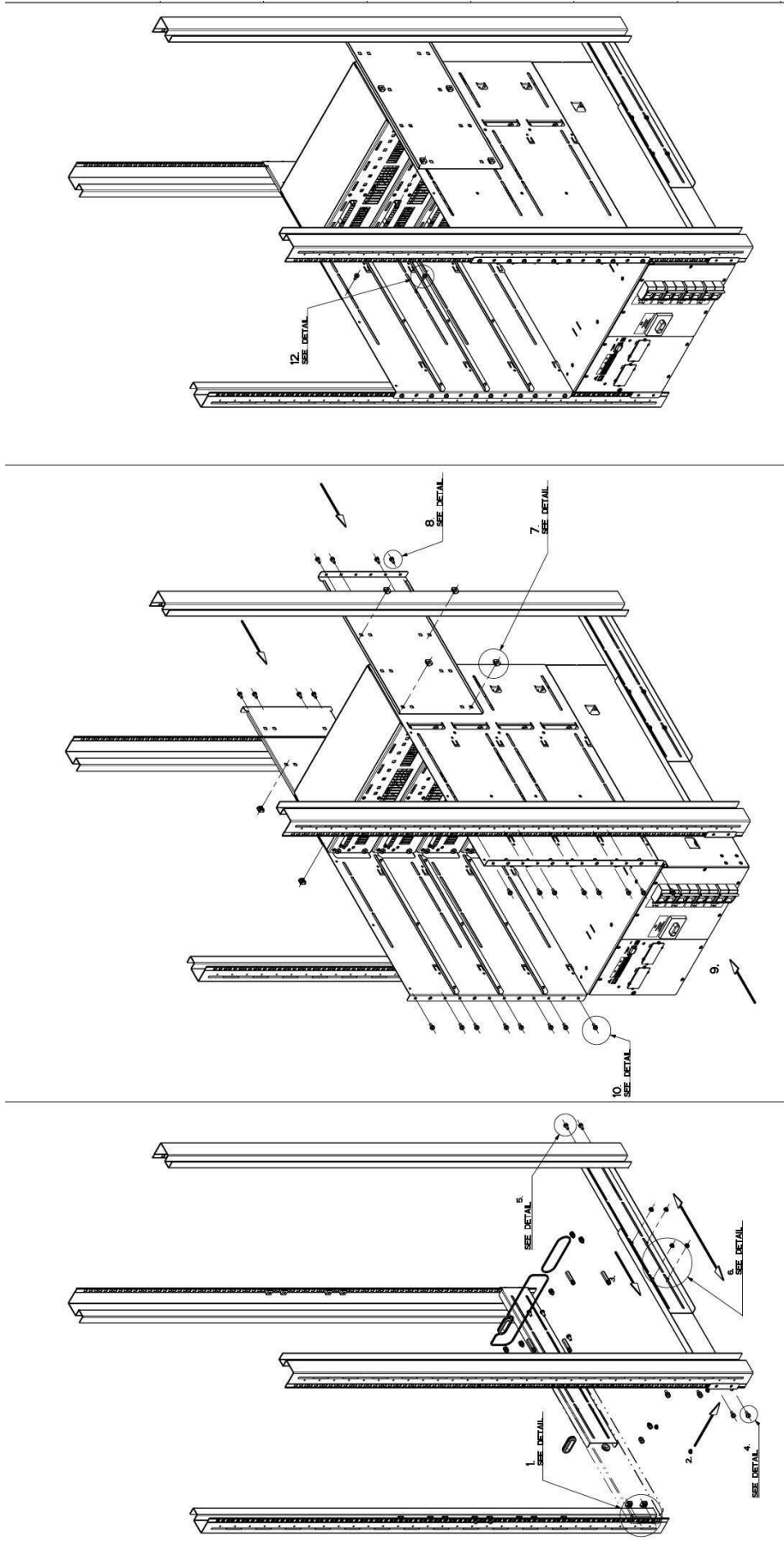


Figure 0.1 RI-24 (Type x4)

DETAIL SCALE 1:2		NOT SUPPLIED
DETAIL SCALE 1:2		NOT SUPPLIED
DETAIL SCALE 1:2		NOT SUPPLIED
DETAIL SCALE 1:2		SUPPLIED
DETAIL SCALE 1:2		SUPPLIED
DETAIL SCALE 1:2		NOT SUPPLIED
DETAIL SCALE 1:2		NOT SUPPLIED
DETAIL SCALE 1:2		SUPPLIED



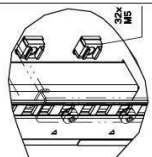
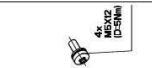

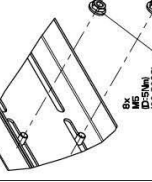
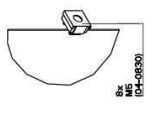



DETAIL SCALE 1/2		NOT SUPPLIED
DETAIL SCALE 1/2		NOT SUPPLIED
DETAIL SCALE 1/2		NOT SUPPLIED
DETAIL SCALE 1/2		SUPPLIED
DETAIL SCALE 1/2		SUPPLIED
DETAIL SCALE 1/2		NOT SUPPLIED
DETAIL SCALE 1/2		NOT SUPPLIED
DETAIL SCALE 1/2		SUPPLIED

Figure 0.1 RI-40 (Type x4)

## 4.5 Power cabling

It is the customer's responsibility to provide all the external fuses, isolators and cables that are used to connect the UPS input and output power supplies.

Paragraph 3.3 describes the following UPS power configurations and provides recommended fuse ratings:

- Single input cabling with common battery (see *Figure 3.5 on page 27*)
- Single input cabling with separate batteries (see *Figure 3.6 on page 28*)
- Dual input cabling with common battery (see *Figure 3.7 on page 29*)
- Dual input cabling with separate batteries (see *Figure 3.8 on page 30*)

Please study the information provided in paragraph 3.3 (see "*Electrical and cabling planning,*" on page 23) before you begin cable installation.



**Key Point:** This information given for guidance only and all fuses, isolators and power cables must be rated and installed in accordance with the prescribed IEC standards or local regulation – e.g. BS7671:2008.

### 4.5.1 Safety notes

Please ensure you read and understand the following safety notes before you begin the UPS electrical installation.

1. Do not start cabling the UPS before its mechanical installation is completed.
2. The power cable installation procedure must be performed or supervised by a qualified electrician.
3. Do not connect power cables to the UPS if there is water or moisture present.
4. Before you work on the UPS power cables or power terminations, you must ensure that the UPS input/bypass mains supplies are isolated and 'locked-out' at their respective mains switchboards. Post warning notices to avoid any inadvertent operation of the UPS external supply isolators. Similarly, ensure that the UPS AC output supply is isolated and locked out at the UPS output distribution panel.
5. Before you connect the UPS power cables ensure that the fuses and cables are suitably rated in accordance with the prescribed IEC standards or local regulations – for example BS7671.
6. Once the electrical installation is completed the UPS must be commissioned by an engineer authorised by Rehiko before it is powered up and brought into use.
7. If an external maintenance bypass facility is used you should familiarise yourself with its operation and input/output power connections as these determine the source/destination of the UPS input and output power cables.



**WARNING:** Do not apply electrical power to the UPS before it has been commissioned.

8. When installing the UPS cables ensure that the connection procedures are performed under the following conditions:
  - a) No mains voltage is present at the UPS mains/bypass switchboard terminals.
  - b) All loads are shut down and isolated at the UPS output distribution panel.
  - c) The UPS is fully shut down and voltage-free.
  - d) The UPS maintenance bypass switch is IA1 is open.

## 4.5.2 Power connections

### Cable access

The PW 8000DPA RI (S2) power cables are connected to a terminal block which is located in the lower rear of the UPS frame behind a safety cover plate. Figure 4.3 shows details for the RI-11 UPS but all models are of similar design.

The diagrams show that the power cables enter the frame through three cable glands fitted to the bottom of the frame – one each for the input mains, bypass mains and UPS AC output cables.

If the UPS is connected to an external battery, the battery cables enter the connection chamber through four cable glands fitted to the terminal block cover plate (as shown); however, the battery cable glands are not fitted to the cover plate for those PW 8000DPA RI (S2) models that have internal batteries.

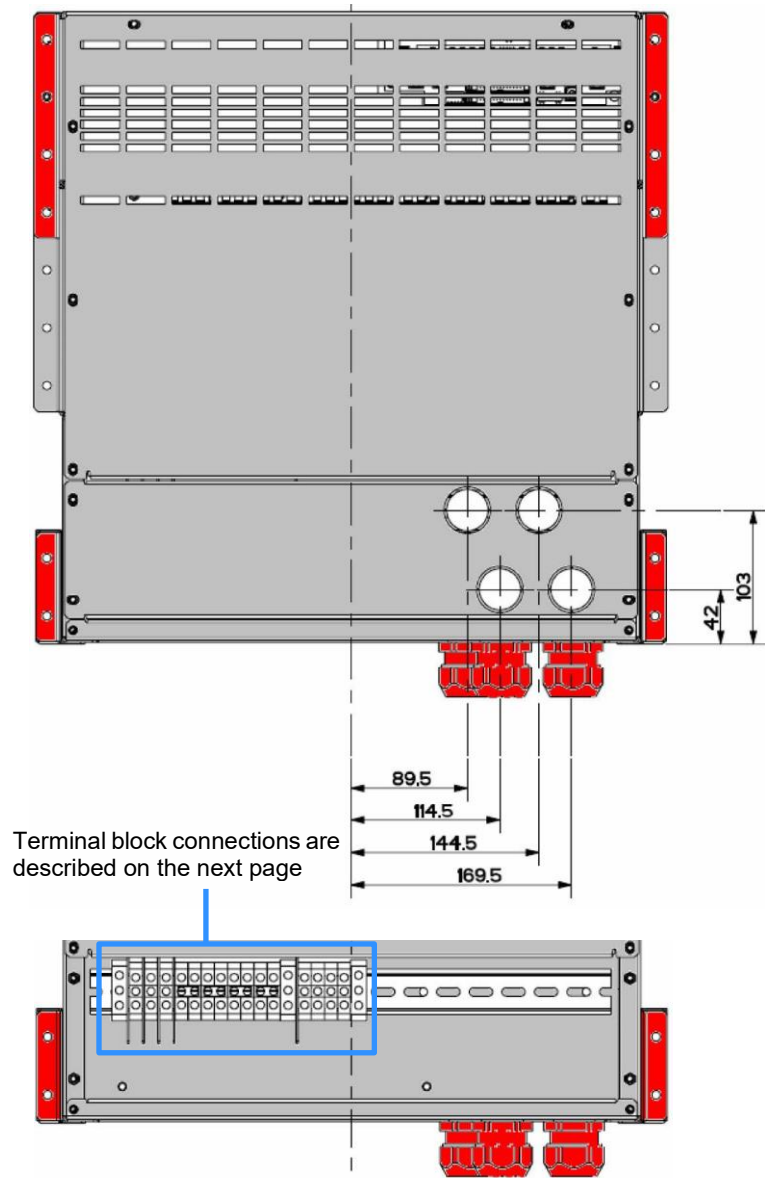
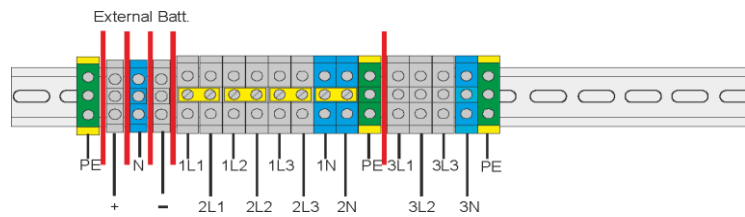


Figure 4.3 Power connections

## Terminal block connections

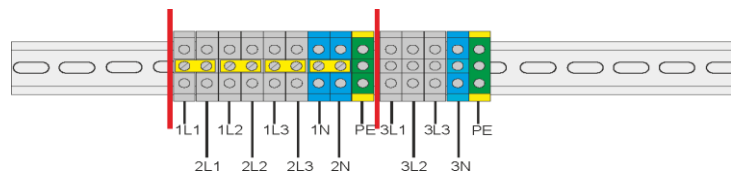
### RI-10 connections

The RI-10 model requires an external battery connected to the battery terminals on the left hand side of the terminal block.



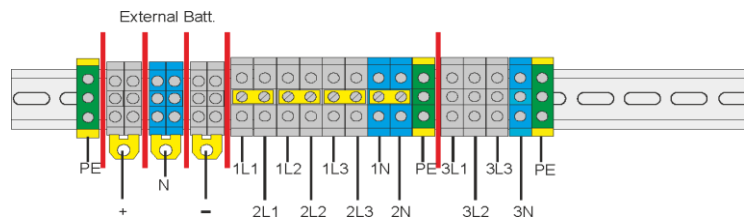
### RI-11 & RI-12 connections

The RI-11 and RI-12 models have internal batteries so no battery terminal block is provided.



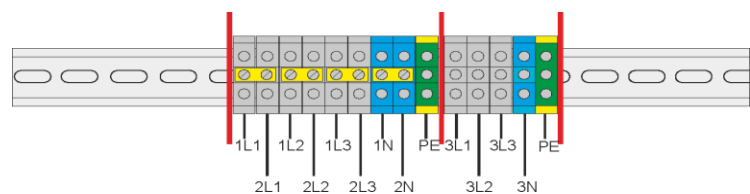
### RI-20 connections

The RI-20 model requires an external battery connected to the battery terminals on the left hand side of the terminal block. As two battery strings can be connected to this model, 'common battery links' are provided (as shown). These must be removed for separate battery installation.



### RI-22 & RI-24 connections

The RI-22 and RI-24 models have internal batteries so no battery terminal block is provided.



### RI-40 connections

The RI-40 model requires an external battery connected to the battery terminals on the left hand side of the terminal block. As four battery strings can be connected to this model, 'common battery links' are provided (as shown). These must be removed for separate battery installation.

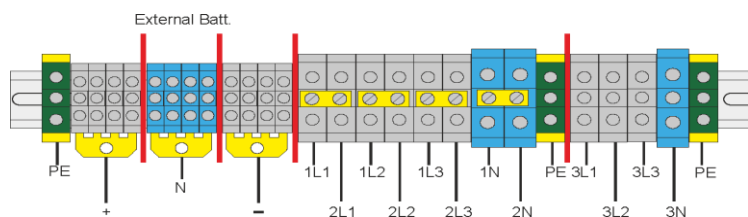


Figure 4.4 Terminal block connections

### Terminal connection size

UPS Model	Batt. Earth (PE)	Separate Batt. (+/N/-)	Common Batt. (+/N/-)	Input Bypass (3+N)	Input Rectifier (3+N+PE)	Output Load (3+N+PE)
RI-10	16/25 mm <sup>2</sup> (T)	3x 10/16 mm <sup>2</sup> (T)	–	4x 10/16 mm <sup>2</sup> (T)	5x 10/16 mm <sup>2</sup> (T)	5x 10/16 mm <sup>2</sup> (T)
RI-11 & RI-12	–	–	–			
RI-20	16/25 mm <sup>2</sup> (T)	2x (3x 10/16 mm <sup>2</sup> ) (T)	3x M5 (B)	4x 16/25 mm <sup>2</sup> (T)	5x 16/25 mm <sup>2</sup> (T)	5x 16/25 mm <sup>2</sup> (T)
RI-22 & RI-24	–	–	–			
RI-40	50 mm <sup>2</sup> (T)	4x (3x 10/16 mm <sup>2</sup> ) (T)	3x M6 (B)	3x 50 mm <sup>2</sup> (T) +N 70/90 mm <sup>2</sup> (T)	3x 50 mm <sup>2</sup> (T) +N 70/90 mm <sup>2</sup> (T) +PE 50 mm <sup>2</sup> (T)	3x 50 mm <sup>2</sup> (T) +N 70/90 mm <sup>2</sup> (T) +PE 50 mm <sup>2</sup> (T)

Note: T = Terminal block, B = Bolted connection

#### 4.5.3 Connecting the power cables (single-feed input)

1. Connect an earth cable from the input mains switchboard to the UPS protective earth terminal (PE).
2. If an external battery cabinet is used, connect an earth cable between the battery cabinet and the UPS battery earth terminal (PE).
3. Ensure the single-feed links, shown in yellow in Figure 4.4, between the input mains terminals and bypass mains terminals (i.e. 1-L1 to 2-L1, 1-L2 to 2-L2 and 1-L3 to 2-L3) are fitted.
4. Connect the UPS input mains supply cables to terminals 1-L1, 1-L2, 1-L3. Ensure correct (clockwise) phase rotation.
5. Connect the input mains neutral to terminal 1N.



**CAUTION:** The input neutral cable must be unswitched and grounded.

#### 4.5.4 Connecting the power cables (dual-feed input)

1. Connect an earth cable from the input mains switchboard to the UPS protective earth terminal (PE).
2. If the bypass mains supply is obtained from a different mains switchboard to the input mains supply, connect an earth cable from the bypass mains switchboard to the protective earth terminal (PE).
3. If an external battery cabinet is used, connect an earth cable between the battery cabinet and the UPS battery earth terminal (PE).
4. Remove the single-feed links, shown in yellow in Figure 4.4, between the input mains terminals and bypass mains terminals (i.e. 1-L1 to 2-L1, 1-L2 to 2-L2 and 1-L3 to 2-L3). Leave the neutral link connected between 1N and 2N.
5. Connect the UPS input mains supply cables to terminals 1-L1, 1-L2, 1-L3. Ensure correct (clockwise) phase rotation.
6. Connect the input mains neutral to terminal 1N.
7. Connect the UPS bypass mains supply cables to terminals 2-L1, 2-L2, 2-L3. Ensure correct (clockwise) phase rotation.
8. If the bypass mains supply is obtained from a different mains switchboard to the input mains supply, connect the bypass mains neutral to terminal 2N (ensure the neutral link is connected between 1N and 2N).

Note: If the input mains and bypass mains are connected to the same switchboard the 2N cable is not necessary.



**CAUTION:** The input neutral cable(s) must be unswitched and grounded and the neutral terminals 1N & 2N must be linked.

Note: The UPS commissioning engineer will re-configure the UPS electronics to operate with a dual feed input at the time of commissioning.

#### 4.5.5 Connecting the UPS output cables

We recommend that the UPS AC output is connected to a dedicated output distribution panel.

Before you connect the UPS output cables to the output distribution panel:

- Verify that the projected load does not exceed the UPS output power rating (OUTPUT POWER on the nameplate).
  - Ensure the load circuit breakers on the output distribution panel are correctly sized with respect to the individual load ratings and associated cabling.
  - Ensure that the maximum total load rating, and the maximum load rating of each individual load socket, is indicated on the output distribution panel.
1. Connect the earth cable from the output distribution panel to the UPS protective earth (PE) terminal.
  2. Connect the UPS AC output cables between terminals 3-L1, 3-L2, 3-L3 and the appropriate connections at the load distribution panel. Ensure correct (clockwise) phase rotation.
  3. Connect the UPS output neutral cable between terminal 3-N and the load distribution panel.



**CAUTION:** *The output neutral cable must ALWAYS be connected.*

#### 4.5.6 Connecting the battery

##### **IMPORTANT NOTE**

The batteries must be installed and connected to the UPS by an approved Rehiko commissioning engineer. High voltage battery strings can be extremely dangerous and **should not** be installed by the customer's installation team.

It is the customer's responsibility to provide any external DC power cable containment facilities between the UPS cabinet and battery cabinet where necessary – e.g. cable trays or trunking. Contact Rehiko for further installation advice if required.

## 4.6 Remote monitoring and control facilities

### 4.6.1 PW 8000DPA RI (S2) communications interface

Various optional remote monitoring and control facilities can be connected to the PW 8000DPA RI (S2) communications interface located on the front of the UPS frame. These are described in Chapter 8.

Although all the connected optional features will be checked by the commissioning engineer, they can be connected by the customer installation team at this point provided no external power is applied to the circuits until they have been properly commissioned.

## 4.7 Installation completion

This now completes the installation process.



**WARNING:** Ensure that power is not applied to any part of the UPS or its connected optional facilities until the UPS has been commissioned and handed over.

# 5. Operating Instructions

## 5.1 Introduction

The Rehiko PW 8000DPA RI UPS system must be commissioned by a fully trained engineer authorised by Rehiko before it is put into use.

The commissioning engineer will:

- Check the UPS electrical and mechanical installation, and operating environment.
- Install and connect the UPS batteries.
- Check and complete the UPS configuration settings.
- Check the installation and operation of any optional equipment.
- Perform a controlled UPS start-up and fully test the system for correct operation.
- Provide customer training and hand over the system in a fully working condition.



**WARNING:** Rehiko will not accept responsibility for the equipment or the safety of any personnel if the UPS system is operated before it has been fully commissioned.  
The manufacturer's warranty will be invalidated if power is applied to any part of the UPS system before it has been fully commissioned and handed over to the customer.

### 5.1.1 Operating procedure summary

Under normal circumstances all the UPS modules in a multi-module system are turned on and operating in the 'on inverter' mode. If one module fails in a redundant module system the faulty module will shut down but it will not affect the remaining module(s), which will continue to operate normally. If necessary, the failed module can then be removed or tested off-line.

If a UPS module fails in a non-redundant system, the load will immediately transfer to the static bypass and the load will be powered from the unprotected bypass mains supply.

When starting and stopping the UPS the system goes through four operational states, as shown in Figure 5.1. The procedures contained in this chapter describe transitions between these states as follows:

- *How to start the UPS system from a fully powered-down condition - see paragraph 5.2*
- *Operating in ECO (on bypass) mode - see paragraph 5.3*
- *How to transfer the load to the maintenance bypass - see paragraph 5.4*
- *How to shut down the complete UPS system - see paragraph 5.5*

### 5.1.2 General warnings



**WARNING:** These operating procedures should be performed by a trained operator.



**WARNING:** When the UPS system is operating on BYPASS or via the MAINTENANCE BYPASS SWITCH, the load supply is unprotected if the bypass mains supply fails. It is essential that the load user is informed of this possibility before you intentionally select either of these operating modes.



**WARNING:** When the UPS is shut down, power is still applied to the UPS input/bypass terminals unless the mains supplies are isolated at the incoming switchboard. It is not permissible to turn off the bypass mains supply if the load is intentionally connected via the internal maintenance bypass switch (IA1) as this will also disconnect the load power.

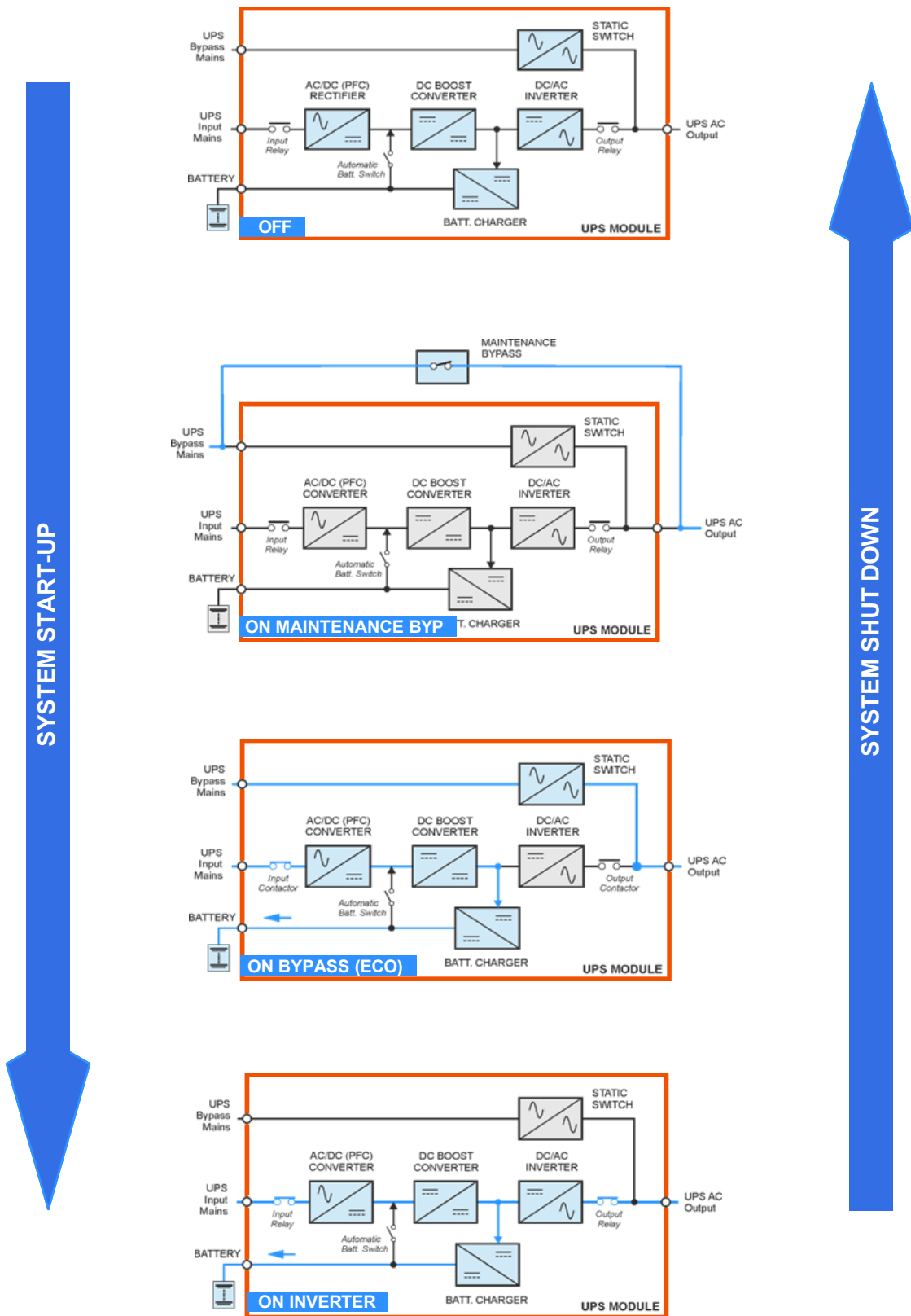


Figure 5.1 Operating procedure transitions

## 5.2 How to start the UPS system from a fully powered-down condition

### IMPORTANT NOTE

In the following procedures, all references to the 'Maintenance Bypass Switch' apply to the internal maintenance bypass switch (IA1) unless the system is connected to an external maintenance bypass facility.

If an external maintenance bypass facility is installed all references to the 'Maintenance Bypass Switch' apply to the maintenance bypass switch in the external facility.



**Key Point:** To reduce the possible effects of high inrush currents that might occur when turning on large loads, we recommend that you initially power-up the load when the UPS system is operating on the maintenance bypass then transfer it to the UPS inverter(s), as described in this procedure.



**CAUTION:** You should familiarise yourself with the operation of the external maintenance bypass circuit operation before using this procedure.

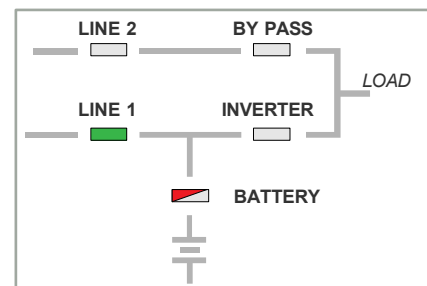
### Initial conditions:

This procedure assumes the following initial conditions (for each module in a parallel system):

- The UPS maintenance bypass switch is open.
- The external UPS system output isolator on the output distribution panel is open.
- The UPS input/bypass supply fuses or (breakers) are open (OFF) at the incoming mains switchboard.
- The battery fuses (F4-x) are open (OFF).

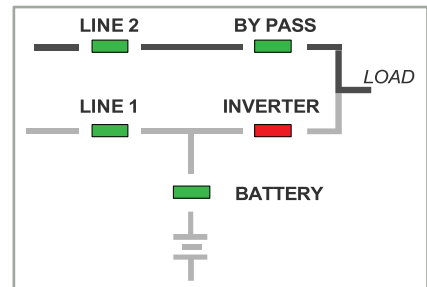
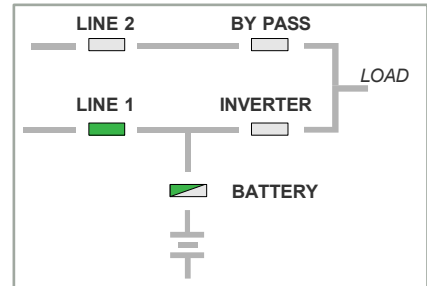
### Power-up the load:

1. Turn ON the UPS system input/bypass mains supply.
  - a) Power is now applied to the UPS module(s), but it is turned OFF.
2. On the module control panel (of ALL modules) verify that:
  - a) The LINE 1 LED is green.
  - b) The BATTERY LED is flashing red.
  - c) All other mimic LEDs are OFF
  - d) The LCD displays LOAD OFF , SUPPLY FAILURE.  
If necessary press the RESET button to obtain this display.
3. Close the external UPS system output isolation device on the output distribution panel.
4. Close the UPS maintenance bypass switch (see the **IMPORTANT NOTE** above).
5. Turn on power to the load equipment.
  - a) The load is now powered through the maintenance bypass.
  - b) The module control panel mimic indications do not change.
  - c) The LCD displays MANUAL BYP IS CLOSED.
6. Press the RESET button.
  - a) The LCD displays LOAD OFF , SUPPLY FAILURE.



### Start the UPS modules

7. Carry out steps 8 to 10 below (for each module in a parallel module system).
8. Close the fused battery isolator (F4-x) (also close the battery fuse in the external battery cabinet where used).
  - a) The LINE 1 LED is green.
  - b) The BATTERY LED is flashing green.
  - c) All other mimic LEDs are OFF
  - d) The LCD displays LOAD OFF , SUPPLY FAILURE.  
If necessary press the RESET button to obtain this display.
9. On the module control panel, simultaneously press both ON/OFF buttons.
  - a) The UPS module will begin to power up over approximately 60s.
10. On the module control panel, after 60s verify that:
  - a) The LINE 1 LED is green.
  - b) The LINE 2 LED changes to green.
  - c) The BYPASS LED is green.
  - d) The INVERTER LED is red.
  - e) The BATTERY LED is green.
  - f) The LCD displays LOAD NOT PROTECTED .
11. Before you continue, ensure that the indications on the module control panels of ALL modules in a parallel-module system are identical and as described above.

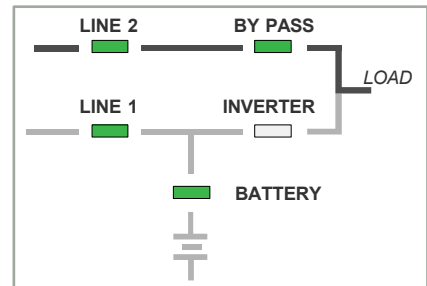


### Transfer the load to static bypass:

12. Only proceed if the module control panel BYPASS LED is green (on ALL modules).

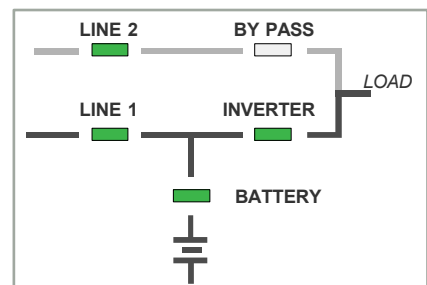
*Note: If the BYPASS LED is not green, repeat step 7 then seek trained advice if it still fails to light green.*

13. Open the maintenance bypass switch (see the **IMPORTANT NOTE** above).
  - a) The module control panel LCD should display MANUAL BYPASS OPEN followed by LOAD NOT PROTECTED.
  - b) The INVERTER led will extinguish.
14. The load is now being powered through the UPS static bypass.
  - a) Check the UPS input and output metered parameters to ensure that they are correct.
  - b) Note any active alarms and take appropriate actions if an alarm cannot be reset.



### Transfer the load to inverter

15. On the module control panel of any UPS module:
  - a) Press the UP key once to access the menu system.
  - b) Use the UP/DOWN keys to move the cursor so that it is adjacent to COMMANDS and then press the ENTER key.
  - c) Use the UP/DOWN keys to move the cursor so that it is adjacent to LOAD TO INVERTER and then press the ENTER key.
  - d) The UPS module output should transfer to inverter (on all modules in a parallel module system).
16. On the module control panel (of ALL modules) verify that:
  - a) The BYPASS LED is extinguished.
  - b) The INVERTER LED changes to green.



The UPS system is now operating in its 'on inverter' mode and providing the load with processed, protected power.

### 5.3 Operating in ECO (on bypass) mode

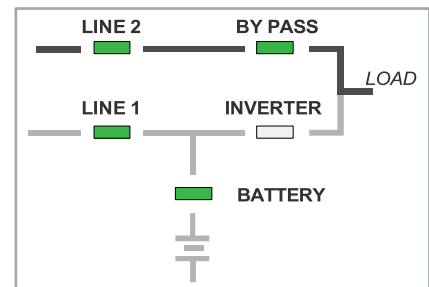
When the UPS system is operated in ECO (on bypass) mode the load is powered from the UPS bypass mains supply, via the static switch, under normal conditions and transfers to the inverter (on inverter mode) automatically if the bypass mains supply fails.



**CAUTION:** There will be a very short supply break when the UPS switches to the 'on inverter' mode, so you should elect to operate the system in the ECO mode only if a load can withstand a brief power break.

#### 5.3.1 How to power-up the UPS system and operate in ECO (on bypass) mode

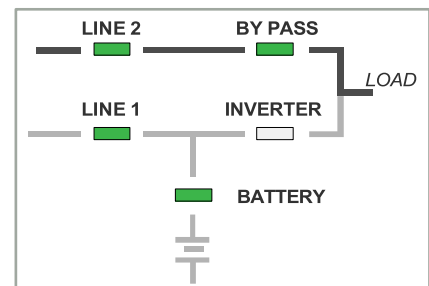
1. To power-up the UPS system from a fully shut down condition, follow the standard UPS system start-up instructions in paragraph 5.2 but do not perform the "Transfer the load to inverter" stage (step 15 onwards).
2. On the module control panel, after 60s verify that:
  - a) The LINE 1 LED is green.
  - b) The LINE 2 LED changes to green.
  - c) The BYPASS LED is green.
  - d) The INVERTER LED is OFF.
  - e) The BATTERY LED is green.
  - f) The LCD displays LOAD NOT PROTECTED.



#### 5.3.2 How to transfer to ECO (on bypass) from on-line (on inverter) mode

The UPS can be manually switched to ECO (on bypass) from the on-line (on inverter) mode using the module control panel load transfer menu.

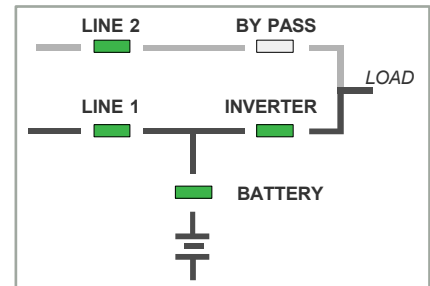
1. On the module control panel (of any module in a parallel-module system) press the ENTER key once to access the menu system.
2. Using the UP/DOWN keys, move the cursor so that it is adjacent to COMMANDS and then press the ENTER key.
3. Using the UP/DOWN keys, move the cursor so that it is adjacent to LOAD TO BYPASS and then press the ENTER key.
  - a) The UPS system will transfer the load to the static bypass (on all UPS modules in a parallel-module system).
4. On the module control panel(s), verify that:
  - a) The INVERTER LED is extinguished.
  - b) The BYPASS LED is green.
  - c) The LCD displays LOAD NOT PROTECTED.



### 5.3.3 How to transfer to on-line (on inverter) fro ECO (on bypass) mode

The UPS can be manually switched to on-line (on inverter) from the ECO (on bypass) mode using the module control panel load transfer menu.

1. On the module control panel (of any module in a parallel-module system) press the ENTER key once to access the menu system.
2. Using the UP/DOWN keys, move the cursor so that it is adjacent to COMMANDS and then press the ENTER key.
3. Using the UP/DOWN keys, move the cursor so that it is adjacent to LOAD TO INVERTER and then press the ENTER key.
  - a) The UPS system will transfer the load to the static bypass (on all UPS modules in a parallel-module system).
4. On the module control panel(s), verify that:
  - a) The INVERTER LED is green.
  - b) The BYPASS LED is extinguished.
  - c) The LCD displays LOAD PROTECTED.



### 5.3.4 How to Turn OFF the UPS system when operating in ECO (on bypass) mode

1. Follow the standard UPS system shut down operating instructions in paragraph 5.4 beginning at step 7 – as the load is already operating on bypass.

## 5.4 How to transfer the load to the maintenance bypass

It may be necessary to transfer the load to the maintenance bypass supply to perform certain UPS service or maintenance operations – for example, when replacing a module in non-redundant system.

This procedure is usually carried out by a trained service engineer and is not part of the normal day-to-day management of the UPS system.



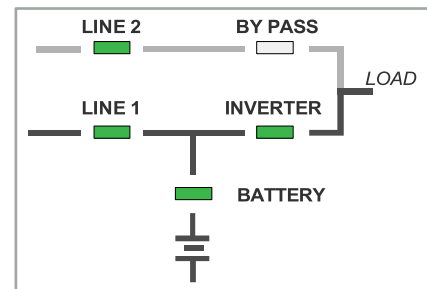
**CAUTION:** Before you carry out this procedure, warn the critical load user that the load will not be supplied with processed, backed-up power once the transfer to maintenance bypass has been performed.

### Initial conditions:

This procedure assumes one of the following two initial conditions.

1. The UPS system is operating normally, 'on inverter'

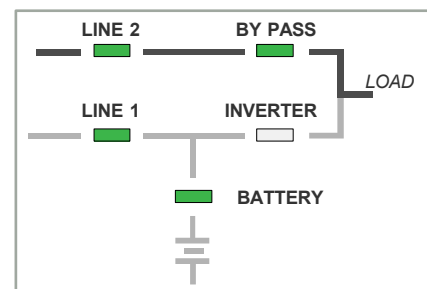
In which case continue with step 3 below:



2. The UPS system is operating with the load 'on bypass' due to either

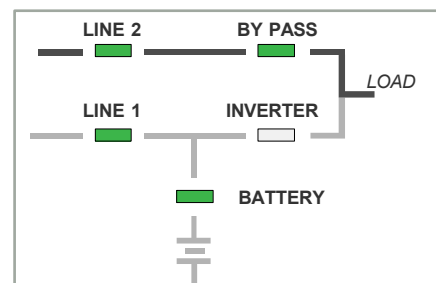
- a system fault
- severe overload
- loss of redundancy
- or operating in 'ECO' mode

In which case continue with step 7 below:



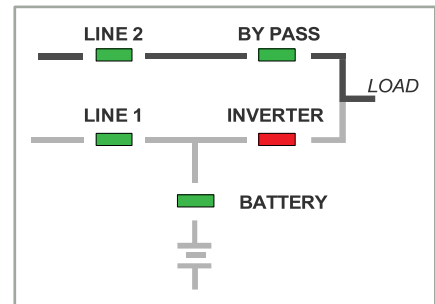
### Transfer the load to the UPS static bypass:

3. On the UPS control panel (on any module in a parallel-module system) press the ENTER key once to access the menu system.
4. Using the UP/DOWN keys, move the cursor so that it is adjacent to COMMANDS and then press the ENTER key.
5. Using the UP/DOWN keys, move the cursor so that it is adjacent to LOAD TO BYPASS and then press the ENTER key.
  - a) The UPS system will transfer the load to static bypass (on all UPS modules in a parallel-module system).
6. On the module control panel(s), verify that:
  - a) The INVERTER LED has extinguished.
  - b) The BYPASS LED is green.
  - c) The LCD displays LOAD NOT PROTECTED.



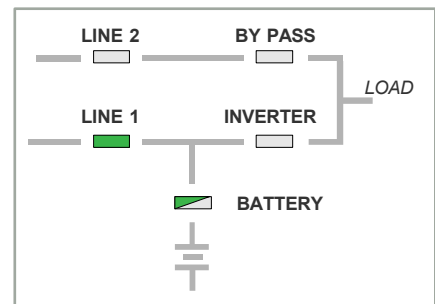
**Transfer the load to maintenance bypass:**

7. Close the maintenance bypass switch (see the **IMPORTANT NOTE** above).
8. On the module control panel(s), verify that:
  - a) The INVERTER LED is red.
  - b) The BYPASS LED is green.
  - c) The module control panel will display MANUAL BYP IS CLOSED.
9. Press the RESET button (on all UPS modules) to cancel the audible alarm.



**Turn off the UPS module(s):**

10. Carry out steps 11 to 12 on each UPS module in turn.
11. On the module control panel, simultaneously press both ON/OFF buttons and verify that:
  - a) All LEDs turn OFF except for LINE 1 and BATTERY (flashing green).
12. Open the battery fuses (F4-x).
  - a) The BATTERY LED will now flash red.



**Key Point:** The UPS system is operating on maintenance bypass and the load is unprotected.



**WARNING:** When using the internal maintenance bypass switch (IA1), the UPS bypass mains supply must be maintained in order to provide power at the UPS output terminals.  
DO NOT OPEN THE BYPASS MAINS SUPPLY FUSES/ CIRCUIT BREAKER.

If an external maintenance bypass facility is used, the UPS modules' input/bypass supply can be turned off – see the operating instructions for the bespoke external maintenance bypass facility for details.



**Key Point:** It is now safe to remove/replace the UPS module(s).

## 5.5 How to shut down the complete UPS system

The UPS system can be completely shut down if the load does not require power for an extended period of time.



**CAUTION:** Before you carry out this procedure, warn the critical load user that power is about to be removed.

1. If the UPS system is not already operating on maintenance bypass, transfer the load to the maintenance bypass and turn OFF the UPS module(s) as described in paragraph 5.4.
2. Turn OFF power to the load equipment by opening the load isolation devices and UPS system output isolation device on the load distribution panel.
3. Open the maintenance bypass switch (see the **IMPORTANT NOTE** above).
4. Turn OFF the UPS input mains and bypass mains supplies at the incoming mains switchboard. Where used, refer to the operating instructions for the bespoke external maintenance bypass facility for additional details of how to isolate the UPS mains supply if necessary.
5. Open any external battery fuses/isolators where fitted.
6. The UPS system cabinet(s) is now voltage free.

# 6. Maintenance

## 6.1 Introduction



**WARNING:** The procedures described in this chapter must be performed by an authorised electrician who has received the appropriate level of training on this UPS system.

The UPS maintenance requirements are minimal as there are no user-serviceable parts contained within the UPS cabinet. However, the UPS contains life limited components that require to be replaced at regular intervals, we recommend that the UPS and batteries are inspected and calibrated on a 6 monthly basis as part of a preventative maintenance schedule to maximise the system's performance, working life and reliability.

## 6.2 User responsibilities

The UPS equipment should be inspected daily to ensure that the environment in which it is operating is kept cool and dust free at all times, and that the operating temperature and humidity is within the limits given in the specifications chapter of this manual. The UPS equipment should also be maintained in accordance with the manufacturer's recommendation and any life limited components replaced at the required intervals and critical updates are performed. Any active alarm or status indication that suggests that the UPS is not functioning correctly should be dealt with immediately by referring to the troubleshooting chapter of this manual or contacting the manufacturer's service desk.

### Routine maintenance



**WARNING:** When working inside the UPS cabinet there is a risk of exposure to potentially lethal AC and DC voltages. All work that requires internal cabinet access must be carried out by trained personnel only.

The commissioning engineer will leave a service record book with the UPS which will be used to log the UPS service history. To ensure optimum UPS operation we recommend that the system's operating parameters are checked and logged every six months.

Preventative maintenance inspections form an integral part of all Extended Warranty Agreements (maintenance contracts) offered by Rehlko. For further details on Extended Warranty Agreements see the warranty information at the front of this manual.

A preventative maintenance inspection includes the following:

- |   |   |
|---|---|
| • Site/environment conditions               | • Integrity of electrical installation        |
| • Cooling airflow                           | • Rectifier/booster operation and calibration |
| • Inverter operation and calibration        | • Static switch operation                     |
| • Battery status and condition              | • Load characteristics                        |
| • Integrity of alarm and monitoring systems | • Correct operation of all installed options  |
| • Condition of life limited components      | • Manufacturer recommended updates            |

### 6.3 Battery testing

A battery test can be initiated from the module control panel and takes approximately 3 minutes to complete. The test procedure can be carried out irrespective of the operating mode ('on inverter' or 'on bypass') and whether or not the load is connected, should be performed only if there are no existing alarm conditions and the battery is initially fully charged.



**WARNING:** Batteries contain dangerous substances that will harm if discarded without due care. Please ensure that any faulty batteries are discarded in accordance with local and national codes of practice for the disposal of hazardous waste.

# 7. Troubleshooting

## 7.1 Alarms

A number of UPS operating parameters and conditions are monitored and will generate an alarm or warning event notification on the UPS control panel if an error is detected or an abnormal condition occurs.

In the event of an alarm occurrence you should:

1. Silence the audible warning.
2. Identify the cause of the alarm by noting any recent events in the UPS module control panel 'event' register.
3. Interpret the cause of the alarm (see below) and seek assistance from your nearest service centre if the cause of the alarm is beyond simple rectification.

### IMPORTANT NOTE

Certain alarm conditions may 'latch-on' even after the cause of the alarm is no longer present. For example, if there is a brief mains failure during unattended operation the MAINS FAIL alarm will activate and it may still indicate a fault condition even after the mains supply has returned to normal. Similarly, a LOAD ON BYPASS alarm might have been caused by an inverter overload, and a brief load transfer to bypass while the fault cleared.

If any alarm appears, the first action you should take is to attempt to RESET it.

If the alarm indication resets then it was probably caused by a transient condition; the UPS has responded correctly and no further action is required. Investigative action is necessary only if it is not possible to reset the alarm or if the alarm occurrence is repetitive, in which case you should seek advice or assistance from the Rehiko Service Department.

## 7.2 Module control panel

The module control panel is described on page 14.

If an alarm condition occurs, the red ALARM led will flash accompanied by an audible warning:

1. Cancel the audible warning by pressing the RESET button.
  - a) If the alarmed condition was transient the audible warning will stop and the red warning light will extinguish.
  - b) If the red warning remains ON it indicates that the cause of the alarm is still present and must be investigated.
2. Investigate the cause of the alarm by making a note of the EVENT LOG, which is accessed from the MAIN MENU – this will present a list of time-stamped events that took place preceding the detected alarm. The module control panel menu map is shown in Figure 2.11 on page 17.
3. Access the MEASUREMENTS screen from the MAIN MENU and make a note of the UPS input, output, battery parameters etc.
4. Refer to the following troubleshooting table for possible fault resolutions.

## 7.3 Troubleshooting table

ALARM CONDITION	MEANING	SUGGESTED SOLUTION
MAINS RECT. FAULT	Input mains power supply is outside prescribed tolerance.	The UPS input mains voltage to UPS is low or missing. If site power appears to be OK, check the UPS input mains supply fuses /circuit breakers etc.
MAINS BYP. FAULT	Bypass mains power supply is outside prescribed tolerance.	The UPS bypass mains voltage to UPS is low or missing. If site power appears to be OK, check the UPS input mains supply fuses /circuit breakers etc.
OUTPUT SHORT	There is a short circuit at the output of UPS (on the load side).	Check for a short circuit on a connected load. Check all output connections and protective devices.
OVERLOAD	Load exceeds the UPS rated power.	Identify which piece of equipment is causing the overload and disconnect it from the UPS.
TEMPERATURE HIGH	UPS temperature has exceeded the allowed value.	Check the ambient temperature of the UPS is <40°C. If the ambient temperature is normal call the authorised service centre for assistance.
INV. PHASE FAULT	Inverter is faulty.	Call the authorised service centre for assistance.
BATTERY IN DISCHARGE	Battery is near end of autonomy	Shutdown the load connected to UPS before the UPS switches itself off to protect its batteries
MANUAL BYP IS CLOSED	Maintenance bypass closed. Load supplied by mains	This alarm is only displayed if the UPS is on maintenance bypass. If this is not a desired state, turn on the UPS system following the correct operating procedure.

## 7.4 Contacting service

Rehiko has a service department dedicated to providing routine maintenance and emergency service cover for your UPS. If you have any queries regarding your UPS please contact us.

### UK

[www.ups.rehko.co.uk](http://www.ups.rehko.co.uk)

[ukservice.ups@rehko.com](mailto:ukservice.ups@rehko.com)

[uktechnicalsupport.ups@rehko.com](mailto:uktechnicalsupport.ups@rehko.com)

[uksales.ups@rehko.com](mailto:uksales.ups@rehko.com)

[ukservicesales.ups@rehko.com](mailto:ukservicesales.ups@rehko.com)

Rehiko web site

Service department – booking service, fault reporting etc.

Technical queries

Hardware sales

Extended warranty agreements etc

### IRELAND

[www.ups.rehko.ie](http://www.ups.rehko.ie)

[ieinfo.ups@rehko.com](mailto:ieinfo.ups@rehko.com)

Rehiko web site

Service department, technical queries, hardware sales and extended warranty agreements

### SINGAPORE

[www.ups.rehko.sg](http://www.ups.rehko.sg)

[salesups.sg@rehko.com](mailto:salesups.sg@rehko.com)

[serviceups.sg@rehko.com](mailto:serviceups.sg@rehko.com)

Rehiko web site

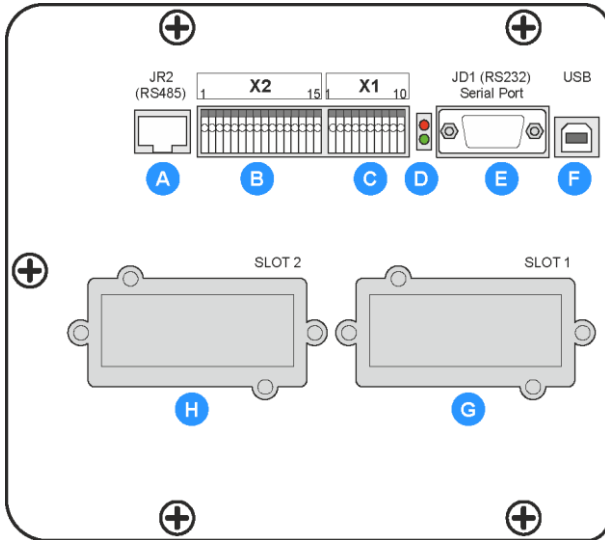
Hardware sales

Contract customer support, maintenance contracts renewals

We recommend that your UPS is protected by an extended warranty agreement. These agreements assist us in caring for your UPS, ensuring that it is well maintained and attended to promptly should any problems occur.

# 8. Options

## 8.1 Customer communications



PW8000-RI Communications interface		
A	JR2	RJ45 Port: Network interface
B	X2	Customer output dry ports:
C	X1	Customer input dry ports:
D	LEDs	Status LEDs:
E	JD1	RS232 Smart port computer interface:
F	USB	Standard USB interface:
G	SLOT 1	Slot for optional modem/Ethernet card ONLY.
H	SLOT 2	Slot for optional SNMP card ONLY

**Figure 8.1 Customer communications**

A communications interface board, located to the lower left front of the frame, offers a range of connections that enable the user to interface the UPS with a local network, building management system or a simple remote alarms facility. All the communications interface board connections are accessible from the front of the UPS cabinet.

### 8.1.1 Customer control inputs (X1)

Terminal block X1 provides a range of standard input interfaces that can be used by the customer as required. All connections are made to Phoenix spring terminals. These terminals will accept wires up to 1.5 mm<sup>2</sup> but we recommend 0.5 mm<sup>2</sup> gauge wires are used for ease of connection.

Four switched inputs are used to signal an external Remote Shut Down, On Generator and a customer-specific function (special application) operation, together with a battery temp sensor input. These are applied to the UPS internal control system via isolation relays fitted on the communications interface board that are controlled directly by the external inputs.

	Terminal	Contact	Signal	Function
<b>X1</b>	X1/10	Gnd	Gnd	UPS-protected+12 Vdc output supply (max 200mA).
	X1/9	In	+12 Vdc*	REMOTE SHUTDOWN (Do not remove the factory-fitted bridge if this feature is not used)
	X1/8	Gnd	Gnd	
	X1/7	In	+12 Vdc*	BATTERY TEMPERATURE SENSING (If connected this input is battery temperature dependent)
	X1/6	Gnd	Gnd	
	X1/5	In	+3.3V	CUSTOMER SPECIFIC INPUT (Function on request to be defined)
	X1/4	Gnd	Gnd	
	X1/3	In	+12 Vdc*	GENERATOR OPERATION (NC = Generator on line)
	X1/2	Gnd	Gnd	
	X1/1	In	+12 Vdc*	

\*+12 Vdc is the terminal open-circuit voltage. This are pulled down to 0V (Gnd) when the external circuit is closed.

## Remote shutdown

The remote shutdown facility comprises a normally-closed switched connected between terminal X1/7 and X1/8.

When the remote switch is opened it shuts down the UPS and turns OFF the UPS output which removes the load supply.

When the remote shutdown option is used, we recommend that a terminal block with linking facilities is installed between the UPS shutdown port and the remote shutdown switch, as shown, in order to allow the removal, maintenance or testing of the remote circuit without affecting the UPS operation.

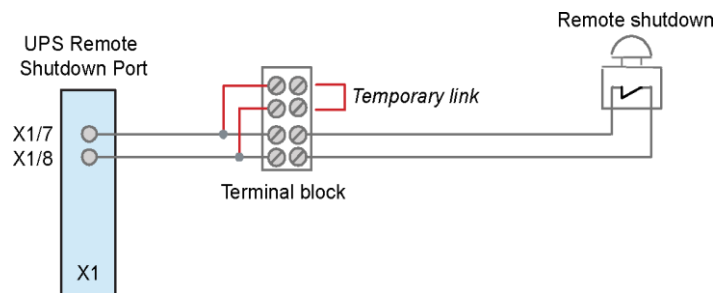


Figure 8.2 Remote shutdown connection

If the remote shutdown option is required, it must be activated by a hardware code on the SETUP SERVICE menu, which will be done as part of the UPS system commissioning process. If you wish to activate this feature after the system has been commissioned please contact Rehko service department for advice.

To fit an external remote shutdown facility:

1. Use a screened cable with 1 pair (section of wires 0.5 mm<sup>2</sup> - 1.5 mm<sup>2</sup>) and maximum length of 100m.
2. Connect the cable as shown in Figure 8.2.



**WARNING:** The remote shutdown is designed to disconnect the UPS AC output supply but does not totally shut down the UPS system. For this reason it should not be considered as an 'Emergency Stop' mechanism. A full Emergency Stop application is available as a factory-fitted option.

## Generator ON facilities

The generator ON facility must use a normally-open contact which closes when the standby generator is running and providing the UPS input power source.

When this option is used, it can be configured to inhibit the operation of the battery charger and/or static bypass while the generator is on-line.

To fit an external remote Generator ON facility:

1. Use a screened cable with 1 pair (section of wires 0.5 mm<sup>2</sup> - 1.5 mm<sup>2</sup>) and maximum length of 100m.
2. Connect the cable as shown in Figure 8.3.

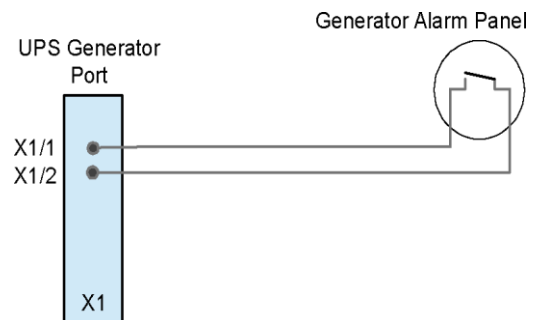


Figure 8.3 Generator ON Connection

## +12V Supply source (X1 9/10)

The UPS-protected +12 Vdc power source available between X1 terminals 9 & 10 can be used as a power source for any external devices, such as relays, that are used as part of the control mechanism that govern the switched inputs.

### Battery temperature sensor (X1 5/6)



**Key Point:** The battery temperature features will only function with the battery temperature sensor supplied by Rehlko. If you attempt to use any other type of sensor it could have a damaging effect on the UPS operation.

The optional battery temperature sensor allows the battery charger to automatically and continuously compensate the battery charging voltage according to the battery temperature

The battery sensor is supplied with a 1.8m long cable, but this can be extended up to 15m if necessary.

To fit the battery temperature option:

1. Install the temperature sensor in the hottest area of the battery installation, typically on the top of the battery cabinet. The supplied adhesive is suitable for use on aluminium, stainless steel and enamelled steel only.
2. Connect the cable to X1 terminals 5/6 as shown in Figure 8.4. These connections are not polarity sensitive.

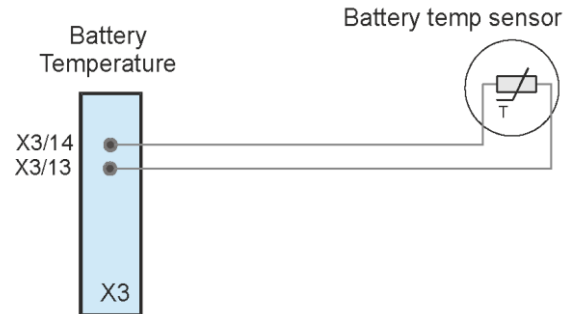


Figure 8.4 Battery temperature sensor

### 8.1.2 Dry port outputs (X2)

	Terminal	Contact	Signal	Display	Function	Contacts
X2	X2/15	Com	ALARM	COMMON_ALARM	Common	
	X2/14	N/C			No Alarm Condition	
	X2/13	N/O			Common Alarm (system)	
	X2/12	Com	MESSAGE	LOAD_ON_MAINS	Common	
	X2/11	N/C			Load On Inverter	
	X2/10	N/O			Load On Bypass (mains)	
	X2/9	Com	ALARM	BATTERY_LOW	Common	
	X2/8	N/C			Battery OK	
	X2/7	N/O			Battery Low	
	X2/6	Com	MESSAGE	LOAD_ON_INV	Common	
	X2/5	N/C			Load On Bypass (mains)	
	X2/4	N/O			Load On Inverter	
	X2/3	Com	ALARM	MAINS_OK	Common	
	X2/2	N/C			Mains Not Present	
X2/1	N/O	Mains Present				

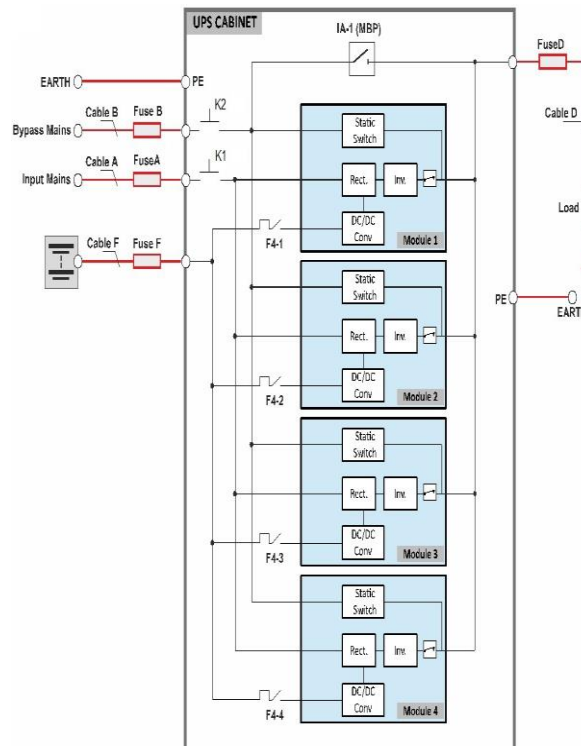
All the dry port output terminals (X2) can accept cables from 0.5 mm<sup>2</sup> to 1.5 mm<sup>2</sup>. X2 outputs are switched by volt-free contacts and are suitable for driving an external alarm panel or providing automatic and orderly shutdown of servers, AS400 or automated building systems. The contacts are rated at a maximum of 30 VAC/6A or 60 VDC/0.7A.

### 8.1.3 Backfeed Protection

The UPS backfeed protection prevents any hazardous voltage or energy from being present on the UPS input AC terminals after interruption of the input AC power.

The backfeed protection is implemented in the DPA UPScale ST by internal backfeed protection contactors (K1 and K2) as shown in the wiring diagram below.

Figure 8.5



**K1 Mains backfeed contactor (option)** In the event of an AC failure, prevents the occurrence of any hazardous voltage at the rectifier mains terminal due to backfeed from the power modules sourced by the battery.

**K2 Bypass backfeed contactor (option)** In the event of an AC failure, prevents the occurrence of any hazard voltage at the bypass input terminal due to backfeed from the power modules sourced by the battery.

### 8.1.4 Serial RS232 Computer interface – USB & JD1 (Smart Port)

A serial RS 232 interface is available through a standard 9-pin D-Type female socket (JD1) or via the USB port.

The RS232/USB interface allows the UPS to be connected to a computer which, when used with appropriate power management software, allows the computer to continuously monitor the input mains voltage and UPS status, and display messages in response to any UPS system changes.

#### USB Port

To establish communication between the UPS and a computer, connect the USB cable that is supplied with the UPS between the UPS USB port and the USB port on the computer. The USB port is compliant with USB 1.1 protocol.

#### JD1 RS232 Port

J1 is a standard 9-pin D-Type female socket which provides an intelligent RS-232 serial port.

Figure 8.6 shows the connector pin-out for a 9-pin and 25-pin.

Note that the maximum length for the interconnecting RS232 cable is 15m.

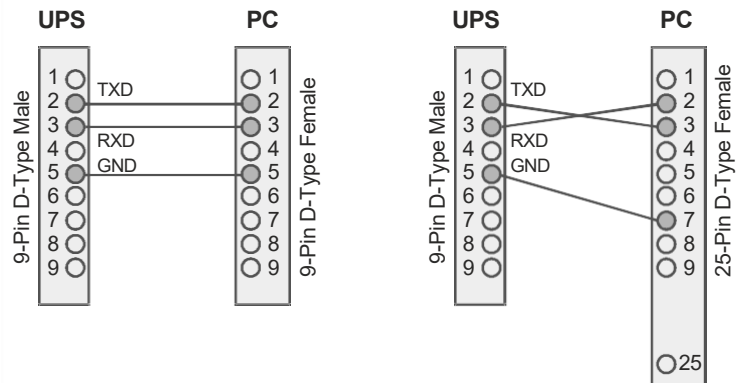


Figure 8.6 Connector Cable - PC Serial Port

### 8.1.5 Network interface card slots

The communications interface board contains two card slots that can be used with a range of network interface cards to interface the UPS system with a building management system or computer network. A suitable network interface card can be chosen to enable the UPS to be monitored and interrogated by one of following protocols:

- Simple Network Management Protocol (SNMP)
- MODBUS over TCP/IP
- MODBUS over RS-485

SNMP is a world-wide, standardised communication protocol and the one that is used most often to integrate the UPS with a wider building/network management system. It can be used to monitor any network-connected device via a simple control language and display the results in an application running within a standard web browser.

An SNMP/Ethernet adapter card contains an RJ-45 connector which can be connected to the network using a standard CAT-5 cable. Once connected, the UPS-Management software agent which is already installed in the SNMP adapter can monitor the UPS operation and output its data to the connected network in SNMP format. In a parallel module UPS system such as the PW 8000DPA RI the SNMP interface can communicate 'system-wide' data or data for an individual UPS module.

The SNMP adaptor card requires a PC with terminal connections and, for normal operation, at least one Ethernet connection. The SNMP card enables event/alarm email traps, server shut down (with optional licenses) and other tasks; and can also be integrated with BMS software over a local area network (LAN) for SNMP or Modbus information over IP.

Alternatively, SNMP connectivity can be implemented using an external SNMP adapter connected to the communications interface board RS232 output (JD1), as shown in Figure 8.7.

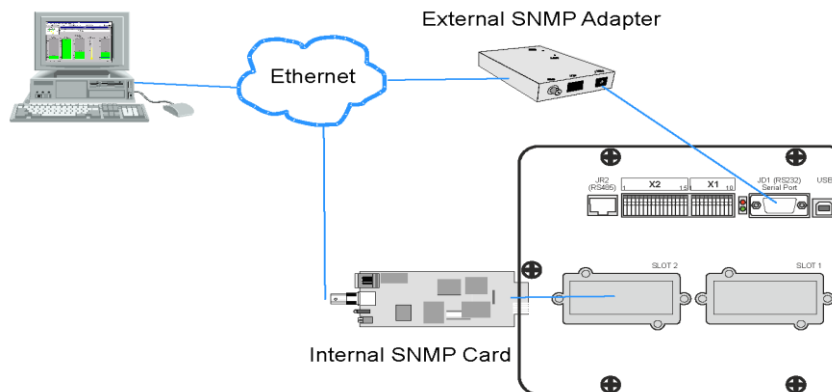


Figure 8.7 SNMP Connection

## 8.2 UPS Monitoring and automated control software

### 8.2.1 The importance of UPS management

The utility supply is inevitably unreliable every now and then; and assuring continuous power to all the facilities connected to it can be a difficult task. The situation is further complicated if worldwide systems are managed via a Local or Wide Area Network (LAN/WAN).

However, by interfacing the PW 8000DPA RI UPS system with purpose-designed network management tools, a System Administrator can take measures to back-up data and prevent system errors in the event of a long utility supply outage.

Suitable UPS management software can enable a System Administrator to monitor all attached networks from a central point and identify bottlenecks at an early stage but, in spite of extensive system monitoring, serious damage can still occur if an administrator fails to intervene in a timely manner. It is therefore important that, when appropriate, the installed UPS software can react automatically to shut down the supplied system in a safe and controlled manner.

Rehiko considers it important to have a complete solution for its UPS systems and offers its customers a number of remote control and monitoring tools to provide optimum protection.

Three (optional) monitoring systems are available for use with the Rehiko PW 8000DPA RI UPS system:

- SNMP – can be used for monitoring and controlled UPS shutdown
- WAVEMON – can be used for monitoring and controlled UPS shutdown
- PowerREPORTER – can be used to automatically email details of monitored parameters and alarm events to Rehiko for appropriate service support response

### 8.2.2 SNMP monitoring software

The SNMP adapter described above requires a PC with terminal connections and, for normal operation, at least one Ethernet network connection. It also requires that the network operating system in use is SNMP-compatible.

### 8.2.3 WAVEMON UPS monitoring and control software

WAVEMON is a bespoke software package, designed to operate in conjunction with many of the systems supplied by Rehiko, which features both UPS monitoring and automatic UPS/server shutdown facilities.

The package is installed on a local PC and communicates with the UPS via USB or an RS-232 serial cable so does not require the purchase of an SNMP card or adapter.

The main features of WAVEMON are:

- on-screen autonomy time/battery time countdown
- on-screen server log-off and shutdown procedure

- time and date stamp event log
- extensive logging of all UPS activity and power quality data
- permits alarm warnings to be monitored remotely via email
- scheduled UPS service mode and other systems status
- graphical user interface for Windows-compatible platforms
- automatic unattended local shutdown
- special modules for MS-Office software to close and save open documents
- compatible with all optional modules like UPSDIALER, SNMP adaptors, temperature sensors, etc.

### Functional description

WAVEMON is a client/server software application designed for networks and local workstations. In general, it consists of two parts: the server module of the UPS management software is *UPSMAN*, which communicates with the UPS via an RS232/USB interface. Running as a background application, *UPSMAN* collects and interprets the messages received from the UPS and places them at the disposal of the client module *UPSMON*, as well as any connected SNMP-based instrumentation and control system.

If *UPSMAN* detects voltage variations or a power failure, it can execute various 'system event' routines, by means of which, for example, the server is switched off or a warning/alarm is sent to the connected users. These 'system event' routines are a part of the management software and can be configured in to suit local application requirements.

The PW 8000DPA RI UPS software unit can be integrated into a network in two ways:

1. By the server which is supplied by the UPS itself and has been integrated into the network.

In most cases this server is used as a sub-agent and you only need the WAVEMON software (without an SNMP adapter). You will also need to establish an RS232/USB connection between the UPS and computer/server.

2. By the use of an SNMP card/adaptor

An SNMP card/adaptor is to be preferred in order to integrate the UPS into the network. In this case up to 50 computers can be shut down in one RCCMD environment. RCCMD (remote console command) is an additional software module that is used in order to execute a command (typically a shutdown command) in a remote system.

### Licensing

A licence is issued with every software serial number for use of what is known as the 'UPS service' on a single server in connection with one UPS and an unlimited number of connected WINDOWS workstations. For operation with two or more servers, a further licence is required for each additional server. In this case it is of no importance whether the UPS service on these servers is active or whether the server was stopped by a remote UPS service. The same applies to the use of RCCMD with the 'remote send/receive' modules for 'multi-server shutdown' under NT, UNIX and other operating systems.

The service programs are generally supplied as single licences. In order to use a single CD-ROM for several 'multi-server shut-down' units you must acquire additional licence codes.

### RCCMD Server shutdown

In order that remote shutdown of servers can take place, initiated by the SNMP card or WAVEMON software, further licenses must be purchased. The license is for the RCCMD client (or listening) software that resides in each target server.

### 8.2.4 PowerREPORTER™ management software

PowerREPORTER is a remote monitoring and management service which provides peace-of-mind protection by offering a continuous (24/7/365) watch over mission-critical facilities. Continuous monitoring is an affordable insurance policy to detect issues and provide an early warning before they develop into a crisis.

The main features and benefits offered by PowerREPORTER are:

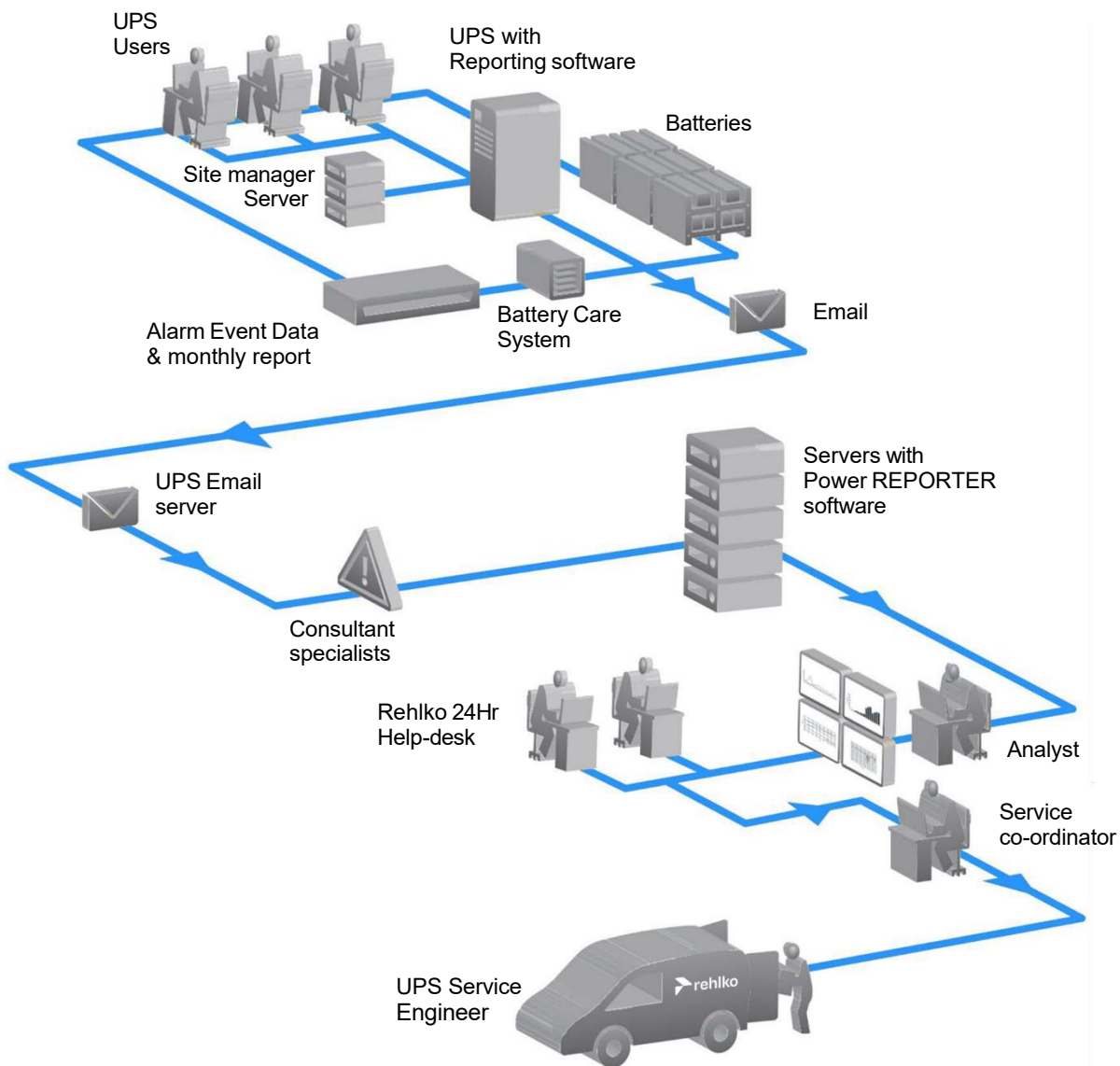
- real time alarm or critical event email notification sent directly to Rehiko service centre
- acquisition of key performance data and productivity information to allow a better understanding of the UPS system performance and quickly troubleshoot downtime events
- improved service level. Combined with a service contract, PowerREPORTER ensures an engineer can determine if site attendance is necessary and bring relevant spare parts
- Monthly status report detailing trends and alarms

An optional battery analysis and care service; PowerNSURE - measures battery voltage, temperature, impedance and prolongs battery service life through the application of battery charge equalization.

**Functional description**

PowerREPORTER communicates constantly with your UPS system to automatically detect any error or alarm messages. If it encounters an incident, PowerREPORTER will automatically transmit a status message, via email, to the Rehlko service centre providing details relating to the identified fault, a snapshot of the UPS performance parameters and a device identification string.

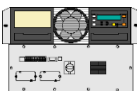
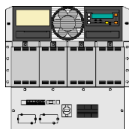
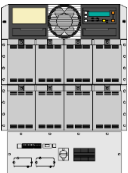
The email automatically alerts the service centre personnel who then remotely diagnose the UPS incident and liaise with the company's field service team so that they can reach the facility with appropriate spare parts within the contracted service agreement time-frame.

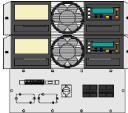
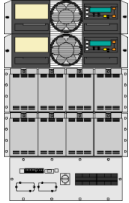
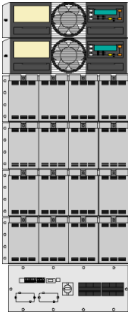


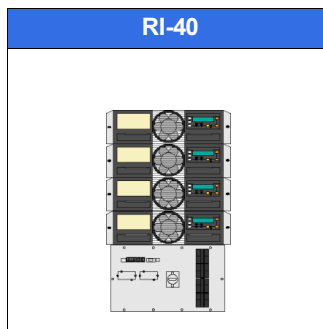
**Figure 8.8 Remote monitoring communications chain**

# 9. Specification

## 9.1 Mechanical characteristics

		RI-10	RI-11	RI-12
				
Configuration accommodates:	Max.	1 module (10 or 20kVA)	1 module (10 or 20kVA) with 40 x 7/9Ah batteries	1 modules (10 or 20kVA) with 80 x 7/9Ah batteries
Max. sub-rack capacity	kW	20	20	20
Dimensions (WxHxD) (with front mounting wings)	mm	448x310x565 (7 HU) 482x310x565 (7 HU)	448x487x735 (11 HU) 482x487x735 (11 HU)	448x665x735 (15 HU) 482x665x735 (15 HU)
Weight of empty frame	kg	20	40	56
Weight of frame with modules and w/o batteries	kg	39 up to 42 (with 1 modules)	59 up to 62 (with 1 module)	75 up to 78 (with 1 module)

		RI-10	RI-11	RI-12
				
Configuration accommodates:	Max.	2 module (10 or 20kVA)	2 modules (10 or 20kVA) with 80 x 7/9Ah batteries	2 modules (10 or 20kVA) with 160 x 7/9Ah batteries
Max. sub-rack capacity	kW	40	40	40
Dimensions (WxHxD) (with front mounting wings)	mm	448x440x565 (10 HU) 482x440x565 (10 HU)	448x798x735 (18 HU) 482x798x735 (18 HU)	448x1153x735 (26 HU) 482x1153x735 (26 HU)
Weight of empty frame	kg	25	66	93
Weight of frame with modules and w/o batteries	kg	62 up to 68 (with 2 modules)	103 up to 104 (with 2 modules)	130 up to 136 (with 2 modules)



Configuration accommodates:	Max.	4 modules (10 or 20 kVA)
Max. sub-rack capacity	kW	80
Dimensions (WxHxD) (with front mounting wings)	mm	448x798x735 (18 HU) 482x798x735 (18 HU)
Weight of empty frame	kg	50
Weight of frame with modules and w/o batteries	kg	124 up to 136 (with 4 modules)

## 9.2 UPS Module characteristics

Mechanical		10 kVA UPS module	20 kVA UPS module
Dimensions (WxHxD) (with front mounting wings)	mm	448 x 132 x 540 (3 HU) 482 x 132 x 540 (3 HU)	
Weight UPS module	kg	18.6	21.5
Colours		Front: RAL 9005	

Input characteristics		10 kVA UPS module	20 kVA UPS module
Output rated power per module $\cos\phi$ 0.8	kVA	10	20
Output rated power per module $\cos\phi$ 1.0	KW	10	20
Nominal input voltage	VAC	3x380/220V+N, 3x400V/230V+N, 3x415/240V+N	
Input voltage tolerance (ref to 3x400/230V) for loads in %:	VAC	(-20%/+15%) 3x308/184 V to 3x460/264 V for <100 % load (-26%/+15%) 3x280/170 V to 3x460/264 V for < 80 % load (-35%/+15%) 3x240/150 V to 3x460/264 V for < 60 % load	
Input frequency range	Hz	35 – 70	
Input power factor		PF=0.99 @ 100% load	
Overvoltage Category		II (2500Vpk)	
Conditional Short Circuit Current (Icc)	kA	25	
Backfeed Protection		Optional	
Inrush current	A	max. I <sub>n</sub>	
Input distortion THDI @ 100% load		< 4.5%	< 3.0
Max. input power with rated output power and charged battery per module (output $\cos\phi$ = 1.0)	kW	10.5	21
Max. input current with rated output power and charged battery per module (output $\cos\phi$ = 1.0)	A	15.2	30.4
Max. input power with rated output power and discharged battery per module (output $\cos\phi$ = 1.0)	kW	11.5	23
Max. input current with rated output power and discharged battery per module (output $\cos\phi$ = 1.0)	A	16.6	33.3

Output characteristics		10 kVA UPS module	20 kVA UPS module
Output rated power per module $\cos\phi$ 0.8	kVA	10	20
Output rated power per module $\cos\phi$ 1.0	KW	10	20
Output current in @ $\cos\phi$ 1.0 (400 V)	A	14.5	29
Output rated voltage	VAC	3x380/220V or 3x400/230V or 3x415/240V	
Output voltage stability	%	Static: $< \pm 1\%$ Dynamic (Step load 0%-100% or 100%-0%) $< \pm 4\%$	
Output voltage distortion	%	With Linear Load $< 1.5\%$ With Non-linear Load (EN62040-3:2001) $< 3\%$	
Output frequency	Hz	50 Hz or 60 Hz	
Output frequency tolerance	%	Synchronized with mains $< \pm 2\%$ (selectable for bypass operation) or $< \pm 4\%$ Free running $\pm 0.1\%$	
Bypass operation		At Nominal Input voltage of 3x400 V $\pm 15\%$ or 196 V to 264 V ph-N	
Permissible unbalanced load (All 3 phases regulated independently)	%	100%	
Phase angle tolerance (With 100% unbalanced load)	Deg	2.0 deg.	
Overload capability on inverter	%	125% load 10 min. 150% load 60 sec.	
Output short capability (RMS)	A	Inverter: $3.0 \times I_n$ during 40 ms Bypass: $10 \times I_n$ during 20 ms	Inverter: $2.25 \times I_n$ during 40 ms Bypass: $10 \times I_n$ during 20 ms
Crest factor		3:1	
Static Bypass transfer time: Inv>Byp/Byp>Inv/Ecomode	ms	$< 1 / < 5 / < 6$	

Heat Dissipation With Non-linear Load		10 kVA UPS module	20 kVA UPS module
Heat dissipation with 100% non-linear load. Per module (EIN 62040-1-1:2003)	W	550	1100
Heat dissipation with 100% non-linear load. Per module (EIN 62040-1-1:2003)	BTU/h	1887	3754
Airflow (25° - 30°C) with non-linear load. Per module (EIN 62040-1-1:2003)	m <sup>3</sup> /h	150	150
Dissipation at no load	W	120	150

Module efficiency		10 kVA UPS module	20 kVA UPS module
Efficiency ac-ac up to (at $\cos\phi$ 1.0) (depending on % module power) (Tolerance $\pm 0.5\%$ applies on all figures)	100%		94.5%
	75%		95.0%
	50%		95.0%
	25%		94.0%
Efficiency with linear load at $\cos\phi = 0.8$ and Efficiency non-linear load (EN 62040-1-1:2003)		Typically up to 1% higher of above values Typically up to 1% lower of above values	
ECO mode efficiency at 100% load	%	98%	

Environmental Characteristics		10 kVA UPS module	20 kVA UPS module
Audible noise with 100% / 50% load	dBA	55 / 49*	57 / 49*
Operation temperature	°C	0 – 40	
Ambient temperature for batteries (recommended)	°C	20	
Storage temperature		-25 - +55**	
Battery storage time at ambient temperature	m	Max. 6 months	
Max. altitude (above sea level)		1000m (3300ft) without de-rating	
De-rating factor for use at altitudes above 1000m sea level according (IEC 62040-3) (ALL MODULES)		Height above sea level (m / ft)	De-Rating Factor for Power
		1500 / 4850	0.95
		2000 / 6600	0.91
		2500 / 8250	0.86
		3000 / 9900	0.82
Relative air-humidity		Max. 95% (non-condensing)	
Accessibility		Totally front accessibility for service and maintenance (no need for side, top or rear access)	
Positioning		Min. 20 cm rear space (required for fan)	
Input and output power cabling		From the bottom on the rear	

\* These are approximate figures for one module only. The audible noise also depends on the characteristics of the host cabinet in which the UPS sub-rack is fitted.

\*\*Elevated storage temperatures may impact useful life, specifically for the UPS capacitors. Ideal storage temperature is between +5 and +35C and at relative humidity of up to 75%. Long term storage in an environment with high humidity should be avoided. Likewise, one should avoid storage environments that contain halogenated gases (and other hazardous gases), sprinkling water or oil as well as exposure to any radiation.

### 9.3 Battery Characteristics

Battery characteristics		10 kVA UPS module	20 kVA UPS module
Battery type		Maintenance free VRLA or NiCd	
Permitted number of VRLA 12V battery blocks	No.	30-50 *	
Permitted number of 1.2V NiCd cells	No.	300-500 *	
Maximum battery charger current	A	4 A (6A on request)	
Floating voltage	VDC	VRLA: 2.26V/cell at 20C - NiCad: 1.4 V/cell	
End of Discharge Voltage	VDC	VRLA: 1.65V/cell at 20C - NiCad: 105 V/cell	
Battery charging curve		Ripple free: IU (DIN 41773)	
Temperature compensation		Standard (temp. sensor optional)	
Battery test		Automatic and periodically (adjustable)	

* Battery capacity usage	10KW UPS Module			20KW UPS Module									
Number of battery blocks	30	32	34-50	30	32	34	36	38	40	42	44	46	48-50
Max. Power in KW	8.6	9	10	12	13	14	14.8	15.6	16	17	18	19	20

## 9.4 Communication Options

Communication options (All systems)	
Module control panel LCD display	1 x LCD display fitted to module control panel of each module
RJ45 Plug (Not used)	RJ45 Plug (for future options)
Customer interfaces: outputs DRY PORT X2	5 Voltage free contacts For remote signalling and automatic computer shutdown
Customer interfaces: inputs DRY PORT X1	1 x Remote Shut down [EMERGENCY OFF (Normally closed)] 2 x Programmable Customer's Inputs (1st default as GEN-ON (Normally open)) (2nd free Programmable Customer's Inputs (Normally open)) 1 x Temp. Sensor for Battery Control 1 x 12 Vdc output (max. 200mA)
Serial ports RS232 on Sub-D9	1 x system frame For monitoring integration in network management and service
USB	1x For monitoring and software management
Slot for SNMP	SNMP card (optional) For monitoring and integration in network management

## 9.5 Standards

Standards	
Safety	EN 62040-1-1, EN 60950-1
Electromagnetic Compatibility	EN 61000-6-4 Prod. Standard: EN 62040-2, EN 61000-6-2 Prod. Standard: EN 62040-2, EN 61000-4-2, EN 61000-4-3 – EN 61000-4-4 – EN 61000-4-5 – EN 61000-4-6
Emission class	C3
Immunity class	C3
Performance	IEC/EN62040-3
Product certification	UKCA CE
Degree of protection	IP 20