



# REHLKO *PW* 9250DPA

Modular three-phase uninterruptible power supply

(50–300 kVA/kW)

Parallelable up to 1500 kVA/kW

## Technical Specification

## Document Control

ISSUE	DATE	REVISION SUMMARY
TS_750_01	02/08/2023	Rebranding to KUP International Version
TS_750_02	15/05/2024	Update Acoustic Noise
TS_750_03	23/07/2024	Update to ICW and ICC
TS_750_04	24/04/2026	Rebranding to Rehlko

## Useful Contacts

### UK

www.ups.rehlko.co.uk

ukservice.ups@rehlko.com

uktechnicalsupport.ups@rehlko.com

uksales.ups@rehlko.com

ukservicesales.ups@rehlko.com

Rehlko web site

Service department – booking service, fault reporting etc.

Technical queries

Hardware sales

Extended warranty agreements etc

### IRELAND

www.ups.rehlko.ie

ieinfo.ups@rehlko.com

Rehlko web site

Service department, technical queries, hardware sales and extended warranty agreements

### SINGAPORE

www.ups.rehlko.sg

salesups.sg@rehlko.com

serviceups.sg@rehlko.com

Rehlko web site

Hardware sales

Contract customer support, maintenance contracts renewals

All product, product specifications and data are subject to change without notice to improve reliability, function, design or otherwise. Rehlko has taken every precaution to produce an accurate, complete and easy to understand specification document and will assume no responsibility nor liability for direct, indirect or accidental personal or material damage due to any misinterpretation of, or accidental errors, in this manual.

© 2026 Rehlko

This document may not be copied or reproduced without written permission of Rehlko.

## Rehiko PW 9250DPA SYSTEM DESCRIPTION

Using a unique modular construction, the Rehiko PW 9250DPA model range represents a completely new generation of medium power 3-phase UPS systems that incorporates the latest technological developments in power engineering. High reliability, upgrade ability, low operating costs and excellent electrical performance are just some of the highlights of this innovative UPS solution. The system's advanced double conversion, Voltage and Frequency Independent (VFI) topology fully satisfies the highest availability and environmentally-friendly requirements compliant with the most stringent safety, EMC and other important UPS standards. It is certified to International Standard ISO 9001/EN 29001 and ISO 14001.

This Technical Specification provides detailed information concerning the mechanical, electrical and environmental performance of the Rehiko PW 9250DPA, and is intended to support and give answers to tender and end-user requirements.

### Rehiko PW 9250DPA model range

#### Single cabinet system (50-300 kW)

The Rehiko PW 9250DPA UPS is based on a standard cabinet that can contain up to six 50 kW UPS modules. The modules are supported on shelf runners located on the cabinet side-walls and plug into heavy duty power sockets fitted to the back of the cabinet, making them easy to install or remove.

With all six 50 kW UPS modules installed, the cabinet can be used as a 300 kW capacity system or 250 kW (N+1) redundant system. This is shown in Table 1 below:

**Table 1 : Individual cabinet capacity rating**

Number of UPS Modules	1	2	3	4	5	6
Capacity system (N+0)	50 kW	100 kW	150 kW	200 kW	250 kW	300 kW
Redundant system (N+1)	–	50 kW	100 kW	150 kW	200 kW	250 kW

Note: System redundancy is entirely load-dependant. For example, a cabinet fitted with three modules (150 kW) can operate as a 'capacity' system for loads between 100-150 kW and as a redundant system (N+1) for loads that are less than 100 kW.

#### Parallel cabinet system (250-1500 kW)

Up to five Rehiko PW 9250DPA cabinets, each containing up to six 50 kW UPS modules, can be connected in parallel to provide a system capacity of up to 1500 kW.

For design reasons, the maximum permissible number of UPS modules that can be connected in a parallel cabinet system is 30.

As shown in Table 2, a five cabinet installation results in a maximum 1500 kW (N+0) capacity system.

**Table 2 : Parallel cabinet system capacity**

No Cabinets	1	2	3	4	5
1 Module	50 kW	100 kW	150 kW	200 kW	250 kW
2 Module	100 kW	200 kW	300 kW	400 kW	500 kW
3 Module	150 kW	300 kW	450 kW	600 kW	750 kW
4 Module	200 kW	400 kW	600 kW	800 kW	1000 kW
5 Module	250 kW	500 kW	750 kW	1000 kW	1250 kW
6 Module	300 kW	600 kW	900 kW	1200 kW	1500 kW

The UPS batteries must be installed in a separate enclosure, or on a battery rack, which is usually positioned adjacent to the UPS cabinet. A range of battery cabinets can be provided.

## System expansion

As just described, the capacity of a Rehiko PW 9250DPA cabinet can range from 50 kW to 300 kW depending on the number of installed UPS modules. If a cabinet is not fully populated, the pluggable nature of the UPS modules makes it easy to install additional modules, to increase the cabinet's capacity, without disrupting the load supply. This 'hot-swappable' design also allows a module to be exchanged while the system remains fully operational (redundancy permitting).

If an additional cabinet is required to expand the capacity of an existing PW 9250DPA system the load will have to be shut down, or transferred to an external 'maintenance bypass' supply, while the extra cabinet is being connected. Therefore, when planning a parallel-cabinet system we recommend that a sufficient number of cabinets is included in the initial system design to cater for any anticipated load expansion. This then allows additional UPS modules to be inserted into the cabinets as-and-when required to match any increase in load demand, without disrupting the load supply.

For example; consider a Rehiko PW 9250DPA (N+1) redundant system where the initial load is around 300 kW but likely to increase in stages to 800 kW. Initially, the system will require a minimum of seven 50 kW UPS modules (300 kW N+1) rising to seventeen modules as the load approaches its predicted 800 kW.

Rather than initially installing a two cabinet system and adding a third cabinet at a later stage, it is beneficial to install a three cabinet system at the outset with the UPS modules distributed between them and add further modules incrementally to match the staged increases in load demand.

## Key features summary

- Decentralised Parallel Architecture (DPA) – highest availability, with near zero down time
- Truly modular design – the Rehiko PW 9250DPA is designed around 50 kW UPS modules
- Hot-swappable modules – enables system expansion and module replacement in a live system
- Compact size, small foot print – output up to 400 kW/m<sup>2</sup> (without battery) saving on expensive floor space
- Flexible battery management – advanced management of battery charging and preventive-failure diagnostics
- High ac-ac efficiency (>97%) even with partial loads – energy and operational cost savings (TCO)
- Full power available from 0.9 lead to 0.7 lag – no de-rating required with leading power factor loads
- Very low input current distortion (THDi <2% @ 100% load) – savings in generator-set power and installation costs
- Back-feed protection as standard

XtraVFI mode reduces the number of modules operating under light load conditions – reduce energy costs (TCO)

## CABINET CONSTRUCTION

Figure 1 shows the location of the major components fitted to the Rehlko PW 9250DPA cabinet for both top and bottom cable entry models.

### 50 kW UPS Modules

The UPS modules are installed on shelf runners located on the cabinet side-walls and plug into heavy duty power sockets fitted to the back of the cabinet. They are secured in place by two bolts that are fitted through mounting flanges on the left and right of the module front panel.

Handles are fitted to the front of the module to assist in inserting and removing the assembly.

### System Display Panel

The System Display Panel displays the operational performance and status of every module connected to the system. Only one System Display Panel is required by a multi-cabinet system as it can display information from each module individually or the system as a whole.

### Output Isolation Switch

The output isolation switch is used to disconnect the cabinet output from the critical load. It is fitted to all cabinets.

### DC (battery) Breakers

The DC Breakers are used to connect the battery to the UPS. Six DC Breakers are fitted, one for each UPS module, and can be wired to connect each module to an individual battery string or a shared battery, depending on the system design.

### External Communication Facilities

The PW 9250DPA features several communication ports, as described on page 12.

### AC & DC Power Cabling

All AC and DC power cables are bolted to busbars that can be accessed by removing the safety cover shown.

### Maintenance Bypass Switch

The 'optional' maintenance bypass switch provides a means of connecting a 'wrap-around' mains supply to enable the UPS cabinet to be totally powered down if required.

*Note: In a multi-cabinet installation the maintenance bypass function is implemented external maintenance bypass facility which contains a 'wrap-around' mains supply that bypasses the entire UPS system*

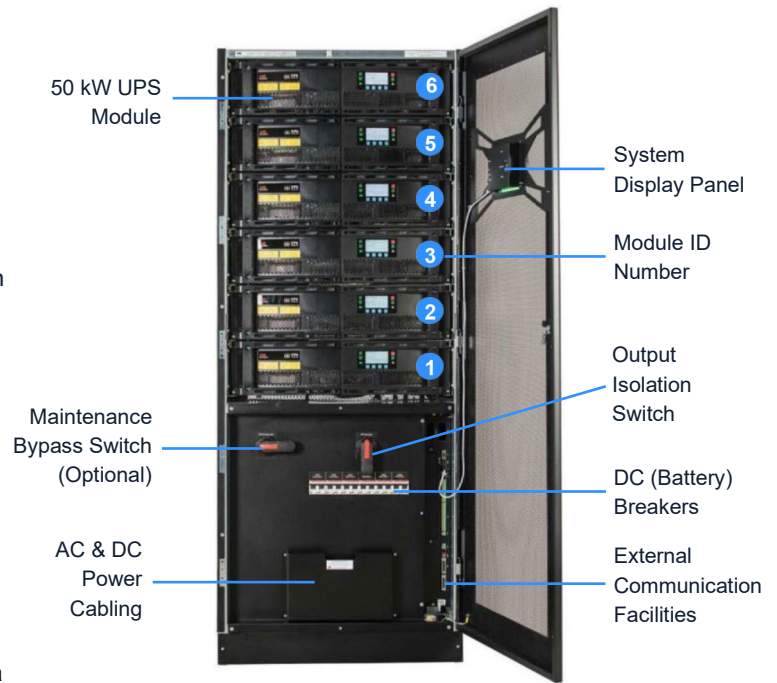

PW 9250DPA With bottom cable entry

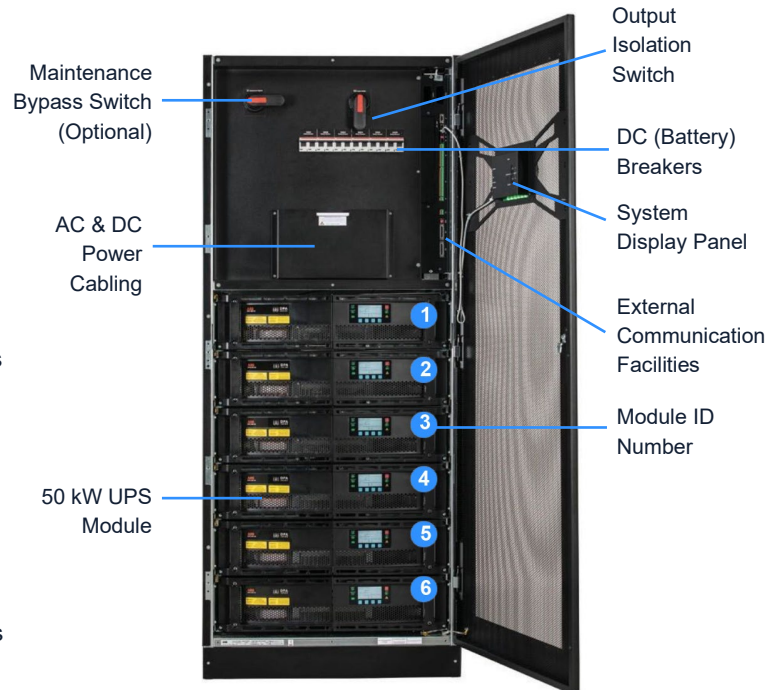

PW 9250DPA With top cable entry

Figure 1 PW 9250DPA Cabinet construction

## GENERAL SPECIFICATION

### UPS Cabinet

NUMBER OF MODULES		1	2	3	4	5	6
Dimensions – height x width x depth	mm	1978 x 795 x 943					
Mass	kg	345	409	474	538	603	667
Acoustic noise at 1m from front of cabinet: – Normal mode	dBA	At 50% load <65 dBA At 100% load 70dBA					
IP Rating		IP 20 (IP21 option available)					
Service access		Front service access (recommended front clearance must be provided)					
Cable entry		Top or Bottom (factory built option, cannot be changed at installation site.)					
UPS Cabinet frame colour		Black (RAL 9005)					

### Input characteristics

NUMBER OF MODULES		1	2	3	4	5	6
Input AC power distribution system compatibility (earthing system)		TN-S, TN-C, TN-C-S, TT					
Input AC power distribution system wiring		3ph + Neutral + PE					
Input rated short circuit withstand current (I <sub>sc</sub> )	kA	10kA for 1.5S					
Conditional short circuit current (I <sub>cc</sub> )	kA	65 kA					
Additional information		Single or dual input feed for rectifier and bypass					
Back-Feed		Standard					
Input voltage	VAC	380, 400, 415 V ph-ph 220, 230, 240 V ph-N					
Input voltage tolerance (@40°C)	%	(-10% to +15%) ≤ 100% load (-20% to +15%) ≤ 80% load (-30% to +15%) ≤ 60% load					
Input voltage tolerance (@30°C)	%	(-20% to +15%) ≤ 100% load (-30% to +15%) ≤ 80% load (-40% to +15%) ≤ 60% load					
Input rated frequency	Hz	50 or 60					
Input frequency tolerance	Hz	35-70					
Input rated current (with batteries charged) – @ nominal input voltage 380V/400V/415V	A	78 75 72	157 150 144	235 225 215	313 300 287	391 374 359	470 449 430
Input rated current (with batteries charging) – @ nominal input voltage 380V/400V/415V	A	83 78 75	166 157 151	249 236 226	332 314 301	415 393 376	498 471 451
Max Input rated current (with batteries charging) Min. input voltage	A	99	198	297	396	495	594
Input distortion THDI – 100% load (linear) in normal mode	%	<3% [at 400V input voltage <2% tolerance ±0.3% may apply]					
Input distortion THDI – 100% load (non-linear) in normal mode	%	<4% [at 400V input voltage <2% tolerance ±0.3% may apply]					
Rectifier input power factor		0.99 @ 100% rated linear/non-linear load					
Rectifier inrush current	%, s	<100% of rated current					
Overvoltage Category		II (2500Vpk) III (4000Vpk) with Internal or external SPD					

## Output characteristics

NUMBER OF MODULES		1	2	3	4	5	6
Output AC power distribution system		TN-S, TN-C, TN-C-S, TT					
Output AC power distribution system wiring		3 ph + Neutral + PE					
Output Rated Voltage	VAC	380, 400, 415 V ph-ph 220, 230, 240 V ph-N					
Output voltage variation – normal or battery operation	%	± 1%					
Output voltage harmonic distortion – normal or battery operation	%	< 2% With Linear Load < 4% With Non-linear Load (EN62040-3:2001)					
Voltage unbalance and phase displacement, with 100% load imbalance	%, °	1%, < 1°					
Voltage transient and recovery time – 100% step load (linear)	%, s	4%, recovery within 2s					
Voltage transient and recovery time – 100% step load (non-linear)	%, s	4%, recovery within 2s					
Voltage transient and recovery time – transfer from Normal to Battery mode	%, s	1%, recovery within 2s					
Output rated frequency	Hz	50 or 60 Hz					
Output frequency tolerance (normal)	%	< ±2% or < ±4% selectable (synchronized with mains)					
Output frequency tolerance (on battery)	%	± 0.1% of rated frequency (free-running)					
Maximum phase error when in sync with bypass	°	2°					
Output rated current – 380V / 400V / 415V configuration	A	76 72 69	151 144 139	227 216 208	303 288 278	379 360 347	455 433 417
Output overload (% of rated current / time duration) at 40 °C, 380/ 400 / 425 V rated voltage	% / s	150% / 1 minute 125% / 10 minutes 110% / continuous					
Output current limit, “short-circuit current” (% or rated current /time duration), 400V rated voltage	% / s	2.9 x In / 150 ms 3.2 x In / 40 ms					
	A	231	462	693	924	1155	1386
Fault clearing capability (Normal and Battery mode)	A gL	20	40	63	80	100	125
Load power factor - rated		1.0					
Load power factor - displacement (permissible lead/lag)		0.6 lag to 0.8 lead					

## Static bypass

NUMBER OF MODULES		1	2	3	4	5	6
Rated current	A	76	152	228	304	380	456
Bypass overload (% or rated current/time duration)	% / s	> 190% / 10s 190% / 2 min 140% / 10 min 110% / continuous					
Bypass fault clearing ability (% of rated voltage @ 400V)	% / s	10 In / 20 ms					
Bypass voltage tolerance (% of rated voltage @ 400V)	%	-20% to +15%					
Bypass protection fuse or circuit breaker rating	A	80					

## Efficiency

NUMBER OF MODULES		1	2	3	4	5	6
Double conversion efficiency –100% load	%	96.9	96.9	96.9	96.9	96.9	96.9
Double conversion efficiency –75% load	%	97.3	97.3	97.3	97.3	97.3	97.3
Double conversion efficiency –50% load	%	97.4	97.4	97.4	97.4	97.4	97.4
Double conversion efficiency –25% load	%	97.3	97.3	97.3	97.3	97.3	97.3

## Battery

NUMBER OF MODULES		1	2	3	4	5	6
Energy storage type		No integrated batteries, external storage needed. Matching battery cabinets available as accessory.					
Technology		VRLA, NiCd, Li-ion,					
Design life, or float service life		Refer to battery manufacture for information					
Quantity of cells and strings	Pcs	VLRA 12V: 40-50 blocks / 240-300 cells per string NiCd 12V: 40-50 blocks / 400-500 cells per string Li-ion (Samsung SD1: 17 modules / 136 cells)					
Nominal voltage	VDC	480V - 600V					
Nominal Ah capacity (C10)		Battery type dependant					
Stored energy time (back-up time @ 100% rated load)	min	Up to any autonomy values without derating.					
Restored energy time (re-charge time to 90% capacity)	hr	VLRA –10 hours NiCd – 10 hours Li-ion – 3 hours					
Recommended temperature for max service life)	°C	Battery type dependant. For VLRA, 20°C; for LIB, 18-28°C					
Nominal discharge current	ADC	110-90	220-175	330-260	440-350	550-435	660-525
Fault rating current	ADC	5 kA					
Float charge voltage	VDC	VLRA – 2.23 V/cell (535V for 40 blocks to 669V for 50 blocks) NiCd – 1.4 V/cell (560V for 40 blocks to 700V for 50 blocks) Li-ion – 4.20 V/cell (571.2V for 17 modules/136 cells)					
End of discharge voltage	VDC	VLRA – 1.68 V/cell (403V for 40 blocks to 504V for 50 blocks) NiCd – 1.05 V/cell (420V for 40 blocks to 525V for 50 blocks) Li-ion – 3.00 V/cell (408V for 17 modules/136 cells)					
Charge current limit (or range)	ADC	38	76	114	152	190	228
Charge power limit	kW	15	30	45	60	75	90
Battery temperature compensation		Supported. With optional temperature sensor.					
Battery test		Automatic battery test facility included with standard UPS					

## Environmental

NUMBER OF MODULES		1	2	3	4	5	6
UPS Cabinet operating temperature range	°C	0-40°C					
Relative humidity range	%	< 95% non-condensing					
Battery temperature	°C	VLRA, 20°C LIB, 18-28°C					
Storage temperature	°C	-25 to +70°C Ideally storage between +5°C and +35°C at RH up to 75%					
Maximum altitude without derating	m	1000m					
Maximum altitude with derating	m	2000m					
Vibration		IAW EN60721-3-2					

NUMBER OF MODULES		1	2	3	4	5	6
Heat Dissipation with 100% Non-linear Load per Module (N+0) (EN 62040-1-1)	W	2100	4200	6300	8400	10500	12600
Heat Dissipation with 100% Non-linear Load per Module (N+0) (EN 62040-1-1)	BTU	7165	14330	21495	28600	35826	42990
Heat Dissipation without load	W	160	320	480	640	800	960
Airflow (25° - 30°C) with Non-linear Load per Module (EN 62040-1-1:2003)	m3/h	460	920	1380	1840	2300	2760

### Compliance Standards

Safety	IEC/EN62040-1
EMC	IEC/EN62040-2
Performance	IEC/EN62040-3
Manufacturing	ISO 9001:2015, ISO 14001:2015, OHSAS 18001

### Standard options

System graphical display	Available for single or parallel cabinet system. Factory fitted only
Top or bottom cable entry	Factory fitted only – not reversible in the field
Single or dual input feed	Field-configurable using links. To suit a common or separate input/bypass mains supply.
Separate or common battery connection	Field configurable by service engineer
Cold start option (start UPS from battery power)	Available for single or parallel cabinet system
Common connectivity option	Customer selected external communications facilities
Maintenance bypass switch	Internal maintenance bypass switch can be fitted in a single cabinet system only

### MODULE CONTROL PANEL

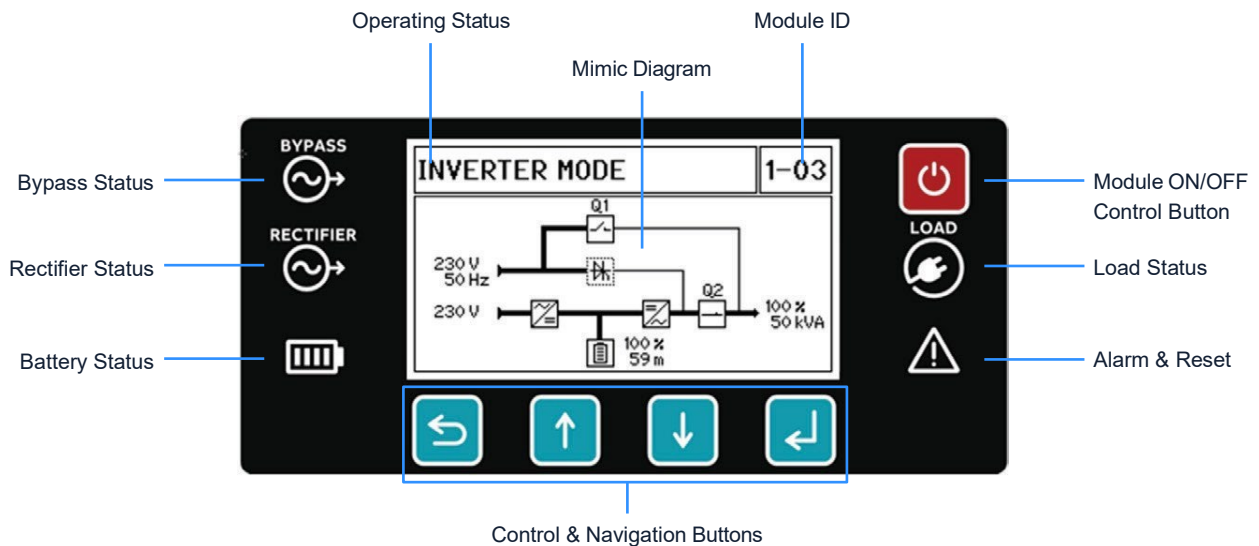

**Figure 2 Module Control Panel**

Each UPS module can be individually controlled and monitored using its module control panel which consists of an LCD display, control and navigation buttons, various LED status indicators and an ON/OFF button.

## LCD Display

The LCD display includes a mimic diagram, operating status bar and the module ID. The LCD display enters a screen-saver mode by turning off the screen after five minutes of non-use. The screen-saver mode is deactivated if any control button is pressed or an alarm pops up.

### Mimic diagram

The module mimic diagram shows operating status of the rectifier, battery, static bypass and inverter. It also provides real-time indication of the voltage, frequency and power measurements for the input, bypass, battery and output.

### Operating Status bar

The module operating status bar indicates the current module operating state, including:

- MODULE OFF
- MODULE DISCONNECTED
- INVERTER MODE
- BYPASS MODE
- BATTERY MODE
- STAND-BY MODE

### Module ID

The module ID identifies the position of the UPS module within the overall UPS system. It is assigned by the commissioning engineer and used by various alarms and event recording functions to identify a particular module.

In a multi-cabinet system the UPS modules in cabinet 1 are identified as 01-06, cabinet 2 as 07-12 and so-on. The numbering sequence within the cabinet depends on whether a top or bottom cable entry is used, as shown in Figure 1. In the screen shown in Figure 2 ID, 1-03; indicates that the module is located in cabinet number 1 in position 03 (is illustrated in Figure 1).

### Control & Navigation Buttons

The control and navigation buttons work in conjunction with the LCD display to allow the user to:

- perform settings and adjustments (some menus have restricted access for service engineer use only)
- monitor the voltages, currents, frequencies, power measurements
- view alarm and event histories
- scroll the main and sub menus in the UPS module.

### Status LEDs

The user is able to identify the status of the bypass, rectifier, battery and the UPS output and the alarm by reading the LED indicators. The LEDs are always active even if the display is in screen saver mode.

## SYSTEM DISPLAY PANEL

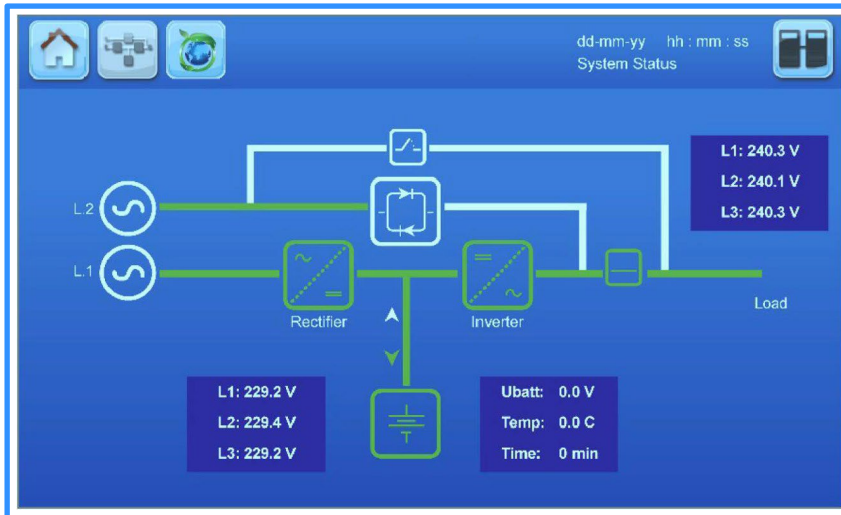

**Figure 3 System Display Panel**

The system display panel contains a microprocessor-controlled TFT touch-screen display which enables the operator to monitor and control the UPS installation at a 'system' level. In a multi-cabinet UPS system, the system control panel is usually installed on the door of the cabinet that contains the 'master' UPS module (Module 01).

The system control panel displays the operational status of the overall UPS system as well as that of each individual UPS module. It enables the operator to:

- view the input/output/battery operating parameters (voltage, current, frequency etc.) for the entire system
- view the input/output/battery operating parameters (voltage, current, frequency etc.) for a selected UPS module
- execute a load transfer from inverter and bypass, and vice-versa
- monitor the power flow through the UPS system, or selected UPS module, through an illuminated, colour-coded mimic diagram
- check alarm and events histories
- acknowledge an event occurrence
- silence alarms
- monitor the battery state and autonomy time

## EXTERNAL COMMUNICATION FACILITIES

A customer interface board is fitted to the right-hand side of the UPS cabinet and its interface connections are available from the front of the cabinet, to the right of the power switch panel. These connections that can be used by the customer to interface the UPS cabinet(s) with a local/wide area network and/or range of external monitoring and control systems –

e.g. as part of a building management system (BMS). Various interface connections are provided, including:

- dry port input connections
- dry port output connections
- two network interface card slots
- RS 232 serial port
- RS 485 serial port
- parallel module interface ports

### RS-232 serial port

The RS-232 serial port (9-pin, D-type) allows the UPS to be connected to a computer for monitoring purposes. It can be connected using a standard serial communications cable with a maximum length of 15m. When used in conjunction with suitable software, this port enables the computer to continuously monitor the input mains voltage and UPS status, and display messages if there are any system changes.

### USB Port

The USB port allows the UPS to be connected to a computer for monitoring purposes, similar to the RS-232 connection. The USB and RS-232 provide a connection to the same data stream and only one port should be used at any particular time.

### SD Card slot

The SD card slot is not in current use.

### Parallel module interface ports

When several cabinets are connected together to form a parallel UPS system their individual electronic control systems must communicate with each other to enable the correct operation of various parallel control functions such as load sharing, frequency synchronisation, and synchronised load transfer. This is achieved by a 'parallel control bus' which carries numerous control signals and can be accessed individually by each module.

In practice, the parallel control bus is connected to two, 25 pin D-type connectors (JD1 and JD2) located on the customer interface board. JD1 is the input connector and JD2 the output connector. These connectors effectively allow the parallel control bus to be connected between all the cabinets in a 'daisy-chain' configuration.

### Parallel configuration

In addition to the parallel control bus, the customer interface board also contains several parallel system configuration facilities, such as DIP switches (S1 and SW1).

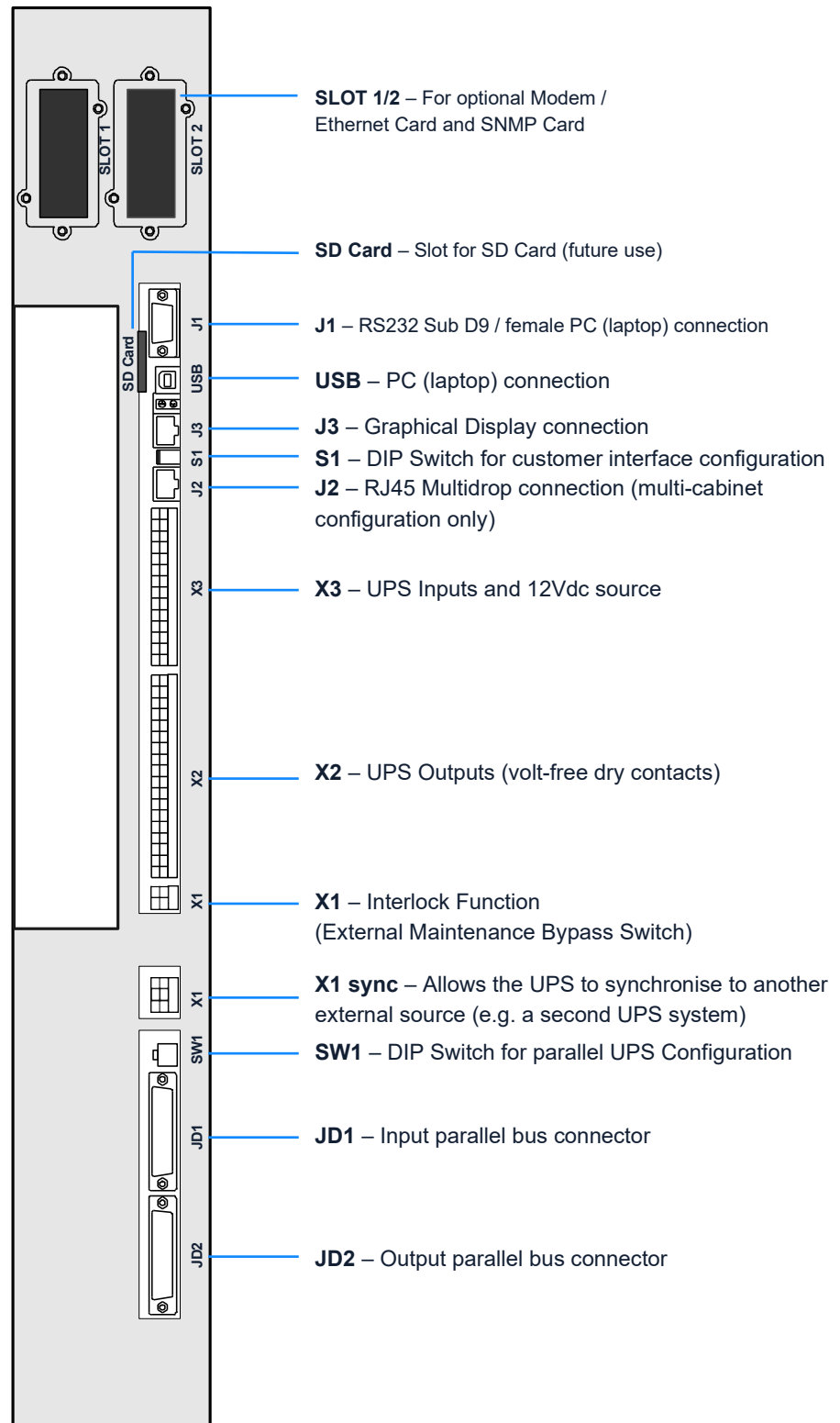

### Multi-drop (parallel system use only)

The optional 'Multidrop' feature, which is used in a parallel cabinet system, allows the customer interface board in the master cabinet to collect data/messages from the other system cabinets via the cables connected to J2. The received data is then processed at a centralised point on the 'master' customer interface board and made accessible to the user on the RS232 port (J1) or USB connection. It is also transmitted to the SNMP card if it is inserted in the relevant card-slot.

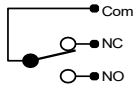
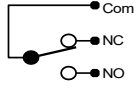
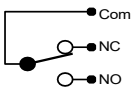
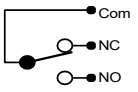

## Dry port output connections output

**Table 3 : Dry port outputs**

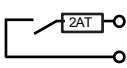
Term	Contact	Signal	Display	Function
X2 / 18		ALARM		Common
X2 / 17				Function on request (to be defined)
X2 / 16				
X2 / 15		ALARM	<b>COMMON_ALARM</b>	Common
X2 / 14				No Alarm Condition
X2 / 13				Common Alarm (System)
X2 / 12		Message	<b>LOAD_ON_MAINS</b>	Common
X2 / 11				Load NOT On Mains
X2 / 10				Load On Mains
X2 / 9		ALARM	<b>BATT_LOW</b>	Common
X2 / 8				Battery NOT Low
X2 / 7				Battery Low
X2 / 6		Message	<b>LOAD_ON_INV</b>	Common
X2 / 5				Load NOT On Inverter
X2 / 4				Load On Inverter
X2 / 3		ALARM	<b>MAINS_OK</b>	Common
X2 / 2				Mains NOT Present
X2 / 1				Mains Present
X1 / 2		-	<b>EXT_MAN_BYP</b>	Interlock Function. Max. 30VDC/2A; 60VDC/0.7A (EXT MANUAL BYPASS) / 2AT
X1 / 1		-		













All the dry port output terminals (X2) can accept cables from 0.2 mm<sup>2</sup> to 1.5 mm<sup>2</sup>. X2 outputs are switched by volt-free contacts and are rated at a maximum of 30 Vac/6A or 60 Vdc/0.7A



**Key Point:** In a parallel cabinet system; the customer interface boards fitted in the slave cabinets are inhibited other than the inputs from the external output breaker and manual bypass breaker, which remain active.

## Dry port input connections

**Table 4 : Dry port inputs**

Term	Contact	Signal	Function
X3 / 14		GND	<b>Battery Temperature</b> (Only compatible with the optional battery sensor from Rehiko)
X3 / 13		+3.3 VDC	
X3 / 12		GND	<b>GENERATOR_OPER_ON</b> Generator Operation (N.O.) Min. contact load 12V / 1mA
X3 / 11		+12 VDC	
X3 / 10		GND	<b>PARALLEL_SW_OPEN / PARALLEL_SW_CLOSE</b> External Output Breaker (N.O.) Min. contact load 12V / 20mA.
X3 / 9		+12 VDC	
X3 / 8		GND	<b>EXT_MAN_BYP</b> External Manual Bypass (N.O.) Min. contact load 20mA
X3 / 7		+12 VDC	
X3 / 6		+12VDC	+ 12 VDC source (UPS protected) (Max. 200mA)
X3 / 5		GND	
X3 / 4		+GND	<b>REMOTE_SHUTDOWN</b> Default setting: disabled. Can be enabled and set it to be NO or NC using the UPS service/communication tool.
X3 / 3		+12 VDC	
X3 / 2		-	<b>REMOTE_SHUTDOWN</b> For external switch Max. 250VAC/8A; 30VDC/8A; 110VDC/0.3A; 220VDC/0.12A
X3 / 1		-	

All the dry port input terminals (X1-X3) can accept cables from 0.2 mm<sup>2</sup> to 1.5 mm<sup>2</sup>.

All cables connected to X3 are inputs and the connected cables should be rated at  $\geq 20$  mA and  $< 50$  Ohms impedance, except for X3 terminals 5/6 which is a UPS-protected 12V (200 mA max) power source that can be connected to the external devices.

## Network Interface card slots

Two network interface card slots enable the UPS system to be connected to a building management system or computer network. The network interface card provides remote UPS monitoring via the web and UPS event log records. The following protocols are offered:

- Simple Network Management Protocol (SNMP)
- MODBUS over TCP/IP
- MODBUS over RS-485

SNMP is the protocol that is most often used to interface the UPS system with a computer network. It is a world-wide, standardised communication protocol that can be used to monitor any network-connected device via a simple control language and display the results in an application running within a standard web browser.

An SNMP/Ethernet adapter contains an RJ-45 connector which allows it to be connected to the network using a standard CAT-5 network cable. Once connected, the UPS-Management software agent, which is already installed in the SNMP adapter, then monitors the UPS operation and outputs its data in SNMP format to the connected network. In a multi-module UPS system the SNMP interface can communicate 'system-wide' data or data for an individual UPS module.

The SNMP adaptor requires a PC with terminal connections, and for normal operation at least one Ethernet connection. The SNMP card enables event/alarm email traps, server shut down (with optional licenses) and other tasks; and can also be integrated with BMS software over a local area network (LAN) for SNMP or Modbus information over IP. Alternatively, SNMP connectivity can be implemented using an external SNMP adapter connected to the UPS RS-232 output.

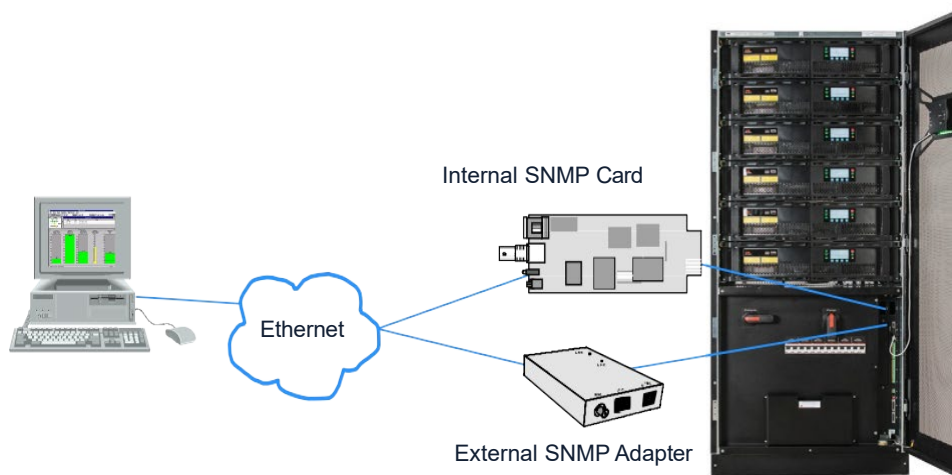

**Figure 5 SNMP Connection**

## OPTIONAL UPS MONITORING AND AUTOMATED CONTROL SOFTWARE

Three (optional) monitoring systems are available for use with the Rehiko PW 9250DPA UPS system:

- SNMP – can be used for monitoring and controlled UPS shutdown
- WAVEMON – can be used for monitoring and controlled UPS shutdown
- PowerREPORTER – can be used to automatically email details of monitored parameters and alarm events to
- Rehiko Ltd. for appropriate service support response

### SNMP monitoring software

The SNMP adapter described above requires a PC with terminal connections and, for normal operation, at least one Ethernet network connection. It also requires that the network operating system in use is SNMP-compatible.

### WAVEMON UPS monitoring and control software

WAVEMON is a bespoke software package which features both UPS monitoring and automatic UPS/server shutdown facilities. The package is installed on a local PC and communicates with the UPS via USB or an RS-232 serial cable.

WAVEMON is only required when an SNMP card or adapter box is not purchased and it is designed to operate in conjunction with many of the systems supplied by Rehiko Ltd.

The main features of WAVEMON are:

- On-screen autonomy time/battery time countdown
- On-screen server log-off and shutdown procedure
- Time and date stamp event log
- Extensive logging of all UPS activity and power quality data
- Permits alarm warnings to be monitored remotely via email
- Scheduled UPS service mode and other systems status
- Graphical user interface for Windows-compatible platforms
- Automatic unattended local shutdown
- Special modules for MS-Office software to close and save open documents
- Compatible with all optional modules like UPSDIALER, SNMP adaptors, temperature sensors, etc.

## Functional description

WAVEMON is a client/server software application for networks and local workstations. In general, it consists of two parts: the server module of the UPS management software is UPSMAN, which communicates with the UPS via an RS-232/USB interface. Running as a background application, UPSMAN collects and interprets the messages received from the UPS and places them at the disposal of the client module UPSMON, as well as any connected SNMP-based instrumentation and control system.

If UPSMAN detects voltage variations or a power failure, it can execute various 'system event' routines, by means of which, for example, the server is switched off or a warning/alarm is sent to the connected users. These 'system event' routines are a part of the management software and can be configured in to suit local application requirements.

The software of your PowerWAVE 9250DPA UPS unit can be integrated into a network in two ways:

1. By the server which is supplied by the UPS itself and has been integrated into the network. In most cases this server is used as a sub-agent and you only need the WAVEMON software (without an SNMP adapter). You will also need to establish an RS-232/USB connection between the UPS and computer/server.
2. In many cases the use of what is referred to as an 'SNMP adapter' is to be preferred in order to integrate the UPS into the network. In this case up to 50 computers can be shut down in one RCCMD environment. RCCMD (remote console command) is an additional software module that is used in order to execute a command (typically a shutdown command) in a remote system.

## Licensing

A licence is issued with every software serial number for use of what is known as the 'UPS service' on a single server in connection with one UPS and an unlimited number of connected WINDOWS workstations. For operation with two or more servers, a further licence is required for each additional server. In this case it is of no importance whether the UPS service on these servers is active or whether the server was stopped by a remote UPS service. The same applies to the use of RCCMD with the 'remote send/receive' modules for 'multi-server shutdown' under NT, UNIX and other operating systems.

The service programs are generally supplied as single licences. In order to use a single CD-ROM for several 'multi-server shut-down' units you must acquire additional licence codes.

## RCCMD Server shutdown

In order that remote shutdown of servers can take place, initiated by the SNMP card or WAVEMON software, further licenses must be purchased. The license is for the RCCMD client (or listening) software that resides in each target server.

## PowerREPORTER™ management software

PowerREPORTER is a remote monitoring and management service which provides peace-of-mind protection by offering a continuous (24/7/365) watch over mission-critical facilities. Continuous monitoring is an affordable insurance policy to detect issues and provide an early warning before they develop into a crisis.

The main features and benefits offered by PowerREPORTER are:

- Real time email notification sent directly to Rehiko UPS Service Centre in response to alarm/critical events
- Acquisition of key performance data and productivity information. Empowers you with the details needed to better understand machine performance and quickly troubleshoot downtime events
- Combined with a service contract, PowerREPORTER improves service levels. The engineer can determine if site attendance is necessary and bring relevant spare parts
- Monthly Status Report detailing trends and alarms

Optional battery analysis and care service; PowerNSURE - measures battery voltage, temperature, impedance and prolongs battery service life through the application of battery charge equalization.

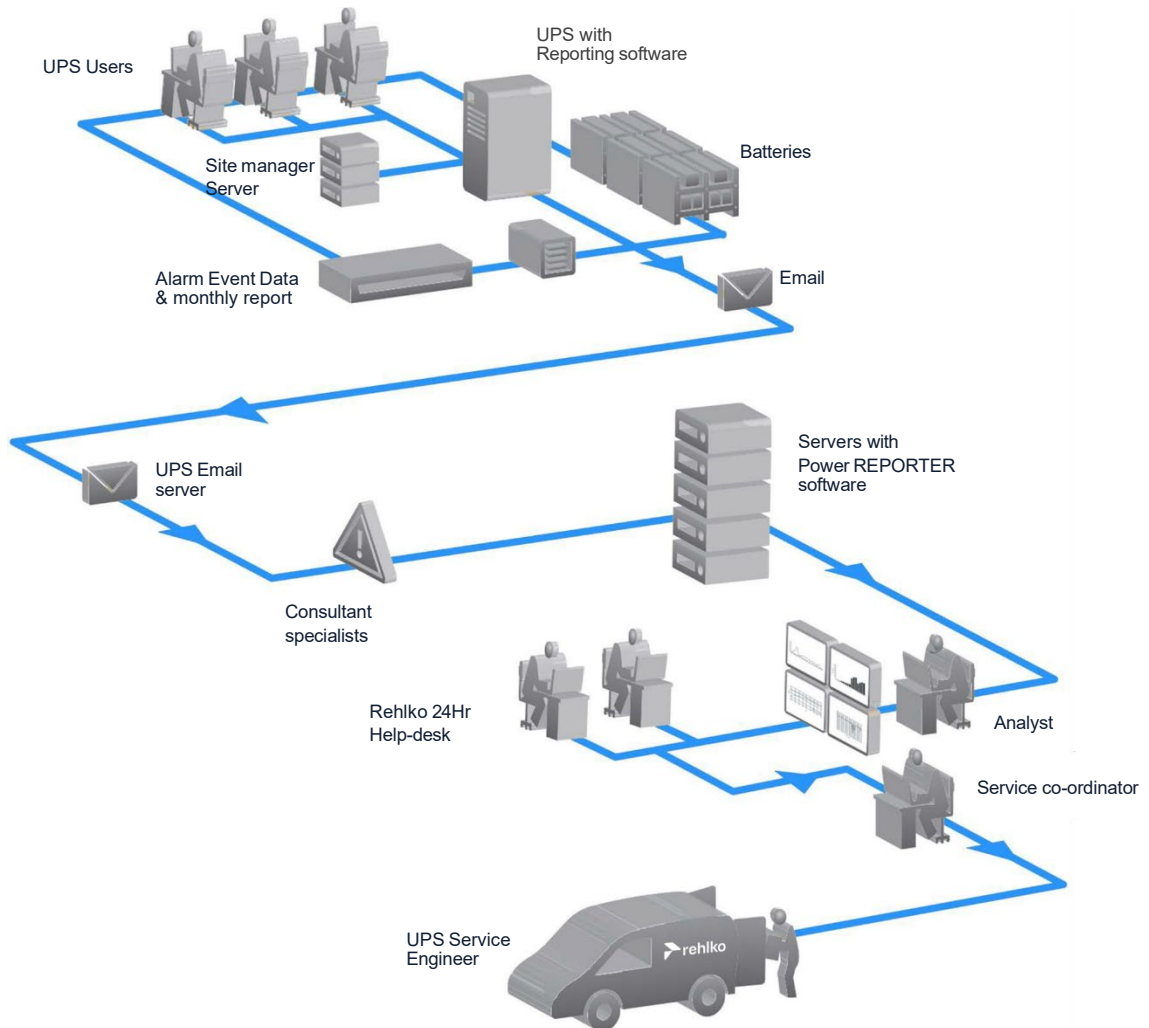

**Figure 6 Remote monitoring communications chain**

**Functional description**

PowerREPORTER communicates constantly with your UPS system to automatically detect any error or alarm messages. If it encounters an incident, PowerREPORTER will automatically transmit a status message, via email, to the Rehiko Service Centre providing details relating to the identified fault, a snapshot of the UPS performance parameters and a device identification string.

The email automatically alerts the Service Centre personnel who then remotely diagnose the UPS incident and liaise with the company's field service team so that they can reach the facility with appropriate spare parts within the contracted service agreement time-frame.

## INSTALLATION PLANNING

A certain amount of pre-planning will help provide a trouble-free installation process. You should consider the following guidelines when planning a suitable UPS location and operating environment.

### Location considerations summary

- The route to the installation location must allow the equipment to be transported in an upright position.
- The floor at the proposed installation site and en-route from the off-loading point must be able to safely support the weight of the UPS and battery equipment, plus fork lift or trolley jack during transit.
- Cooling air enters the front of the UPS cabinet and is extracted by ventilation fans mounted on the cabinet rear. The UPS cabinet requires space to bottom, top and back to enable adequate cooling airflow (see 'Clearances' below).
- The cabinet door must be opened by 115° in order to remove/fit the UPS modules, so the right-hand side of the cabinet cannot be positioned directly against a projecting wall.
- All parts of the UPS required for maintenance, servicing and user operation are accessible from the front of the cabinet and require a minimum front clearance of 1000 mm.
- Provision must be made for cabling the UPS. Top or bottom cable entry options are available that must be stipulated at the time of ordering the equipment as these are factory fitted.

### Environmental considerations summary

The immediate UPS environment should satisfy the following conditions:

- The UPS can operate with in a temperature range of 0-40°C but a temperature of 20°C is necessary to achieve the recommended battery life span.
- The air conditioning system must be able to provide a sufficient amount of air cooling to keep the room at, or below, the maximum desired temperature.
- Adequate cooling air flow must be available.
- Cooling air entering the UPS modules must not exceed +40°C.
- The humidity should be maintained at < 90% non-condensing.
- The floor material should be non-flammable and strong enough to support the heavy load.
- Fire protection standards must be respected.
- The location must be dust free with no corrosive/explosive gases present.
- The location must be vibration free.

## Clearances

The UPS cabinet is force ventilated with cooling air entering the UPS through the ventilation grills in the cabinet door and extracted through vent at the rear of the cabinet with fan assistance. The diagrams below show the minimum clearances that should be allowed around the UPS cabinet to enable adequate cooling airflow dissipation.

### Rehiko PW 9250DPA stand-alone cabinet installation

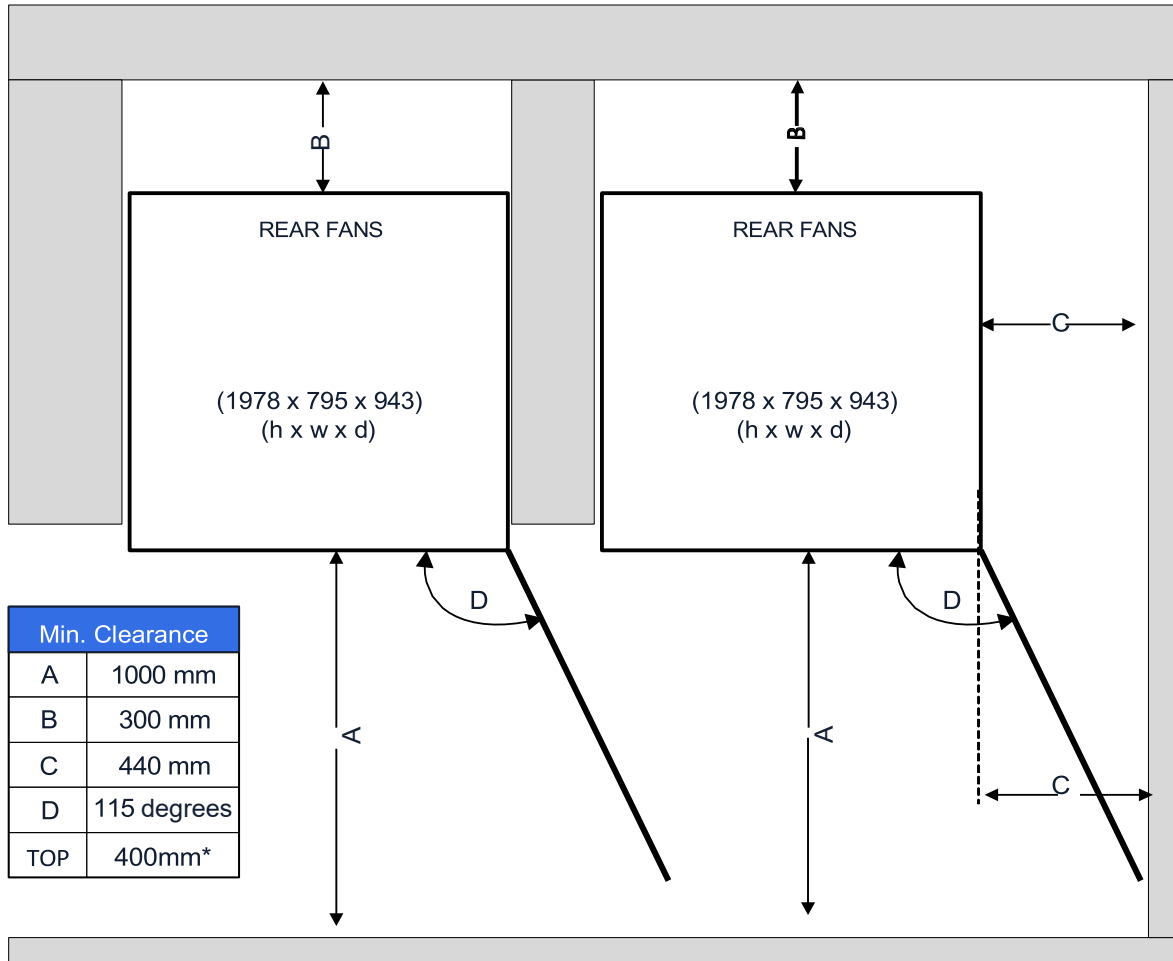

**Figure 7 Clearances for a Rehiko PW 9250DPA stand-alone cabinet**

All the parts of the UPS that might require access for maintenance, service replacement and general operation are accessible from the front of the cabinet and therefore there is no need for any access clearance to be provided at the sides of the cabinet.

It is necessary to open the cabinet door fully in order to extract/fit some major components, including the UPS modules. In order to achieve this the cabinet door must be opened to approximately 115° and where the right-hand side of the cabinet is located against a protruding wall, space must be provided to enable the door to be fully opened. The clearance diagram shows the required side clearance in this case to be approximately 440 mm.

No side clearance is necessary if the right-hand side of the cabinet is not adjacent to a protruding wall (as shown in the left hand diagram in Figure 7).

Although the front clearance is shown as 1000 mm this should be considered as a 'minimum' and where possible it should be increased to allow free passage of personnel with the door open.

\*A TOP clearance of 400mm is required to dissipate the cooling air if there is no side clearance.

### Rehiko PW 9250DPA parallel-cabinet installation

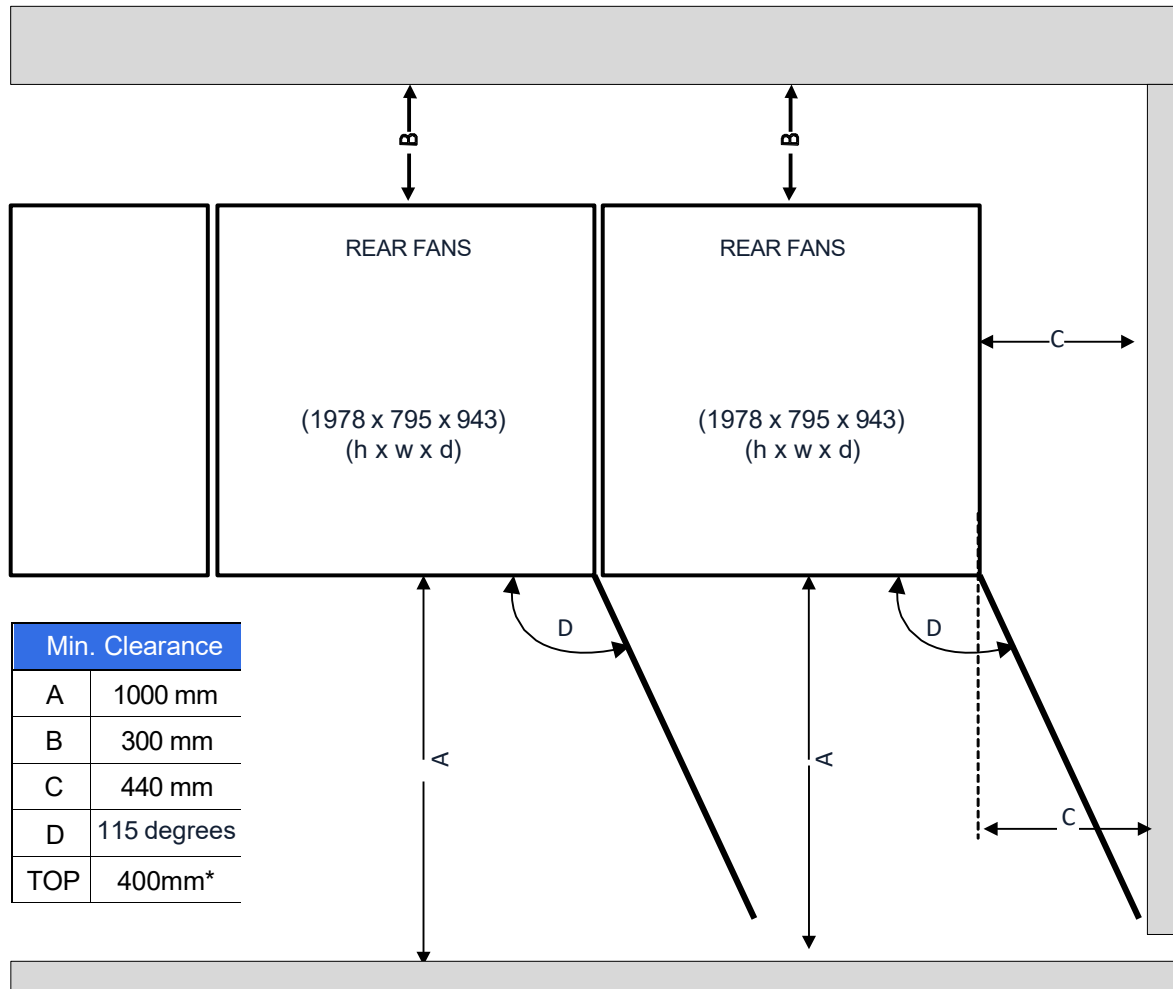

**Figure 8 Clearances for a Rehiko PW 9250DPA parallel-cabinet installation**

The clearances required by a Rehiko PW 9250DPA parallel cabinet installation are similar to those just described for a stand-alone cabinet.

Although Figure 8 shows the same clearances applied to the battery cabinet this will in fact depend upon the battery cabinet manufacture. Before planning a parallel cabinet installation you should ascertain the access clearances required to install and service the battery cabinet.

## UPS POWER CABLING

In the following diagrams all the cables and fuses identified as 'A', 'B', 'C' and 'D' are bespoke to the installation and must be provided by the customer. The required current ratings and cable termination details are shown in the ratings tables on pages 25 to 31.

### Input/Bypass Mains Supply Cables

The UPS cabinet can be wired for a 'single feed' or 'dual feed' input mains supply.

In a 'single feed' system (standard) the UPS input mains terminals and bypass mains busbars are internally linked within the UPS cabinet, but in a 'dual feed' system the links are removed and the UPS bypass mains terminals are connected to a dedicated bypass mains supply. The two configurations are shown in Figure 9.

The input supply and bypass supply neutrals are connected to a common neutral busbar. If the input mains and bypass mains are obtained from the same AC source in a dual feed system it is permissible to connect just one neutral cable.

All input mains and bypass mains cables should be connected through a LV switchgear panel and protected by circuit breakers or fuses to provide overload protection and a means of isolating the UPS from the mains supply when required.



**Key Point:** The input neutral must be unswitched and permanently connected. Do not use a 4-pole input breaker.

*Note: Although the required input cable rating depends upon the number of installed UPS modules, we recommend that the input cables are sized for the full 300 kW cabinet rating even if fewer than six UPS modules are initially installed. This will allow the system to be expanded to its full rating without having to shut it down to up-rate the input cables.*

### UPS Output cables

The UPS output cables should be connected to the load equipment via a suitably fused output switchgear panel.

*Note: Although the required output cable rating depends upon the number of installed UPS modules, we recommend that the output cables are sized for the full 300 kW cabinet rating even if fewer than six UPS modules are initially installed. This will allow the system to be expanded to its full rating without having to shut it down to up-rate the output cables.*

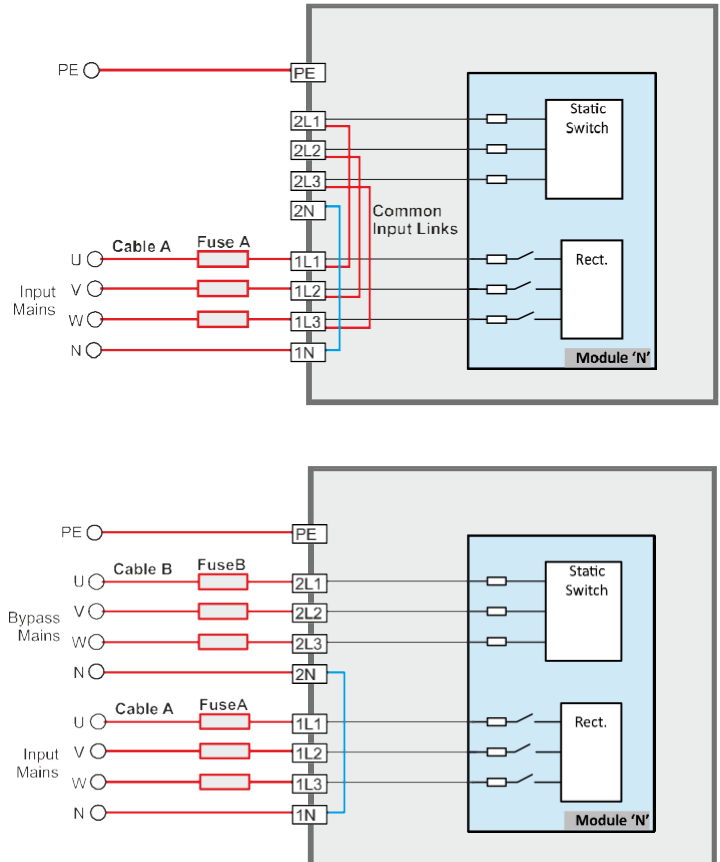

Figure 9 Single and Dual feed input supply options

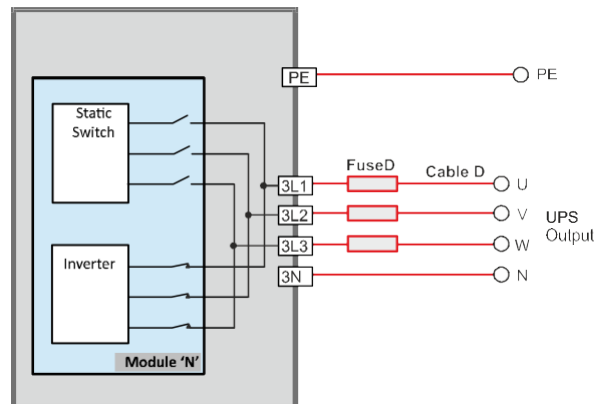

Figure 10 UPS Output cables

## Battery cables

The batteries can be connected to the UPS in either a 'common battery' or 'separate battery' configuration. These are illustrated in figures 11 to 13.

The battery cables (cable C) and fuses (fuse C) are bespoke to the installation and will be supplied by Rehko, the dc cabling must be installed by the commissioning engineer although the containment is normally supplied by the customer. A protection device must be fitted as close to the battery containment as possible. For a 'separate battery' installation, where two or more sets of batteries are installed, a separate circuit breaker or isolation device must be provided for each set.

### Common battery configuration

A 'common battery' installation is shown in Figures 11 and 13.

In this configuration a single battery, which can comprise several parallel battery strings, is connected to the battery busbars (+ve & -ve) within the UPS cabinet from where it is connected to the UPS modules via dedicated circuit breakers (Q501 – Q506). The tables that accompany Figure 11 and Figure 13 show the nominal battery discharge current that the battery cables are required to carry for this type of configuration.

*Note: As with the input and output power cable recommendations, we also recommend that the battery cables are sized for the full 300 kW cabinet rating even if fewer than six UPS modules are initially installed, as this will ease possible future expansion.*

Following a mains outage, if there is a total battery failure in a 'common battery' system the entire UPS is unable to operate from battery power, resulting in the loss of the critical load supply. However, if the battery consists of several parallel battery strings, and the battery failure is in one string only, the UPS will operate on battery power as normal but with a much reduced back-up time.

### Separate battery configuration

A 'separate battery' configuration enhances the overall reliability/availability of the UPS system by providing a degree of battery redundancy – i.e. following a mains outage, the total failure of a battery only affects it's associated module and the remainder of the UPS system can fully support the critical load – assuming n+1 module redundancy.

A 'separate battery' installation is shown in Figures 12 and 14 for a single-feed input and dual-feed input respectively. In these illustrations each battery is connected directly to the module circuit breakers (Q501 – Q506) and not to the main battery busbars (+ve & -ve).

## FUSE & CABLE SIZING

It is the customer's responsibility to provide all the external fuses, isolators and cables that are required to connect the UPS inputs and outputs to their respective power distribution boards and battery system.

### Input/output supply protection

The UPS input/bypass mains supply cables must be connected via an LV-Distribution board in which suitable fuses or circuit breakers are installed to provide both overload protection and a means of isolating the UPS from the mains supply when required. Similarly, the UPS output cables should be connected to the load equipment via a load distribution panel containing suitable load protection devices.

The input/output AC and DC cables and protective devices are identified in Figures 11 to 14. The fuse and cable sizing details given in the following tables are provided for guidance only:

- The UPS must be installed to prescribed IEC or local regulations (e.g. BS7671).
- The required DC cables and battery fuses are bespoke to the installation, depending on the battery type and quantity. Site-specific DC cable and fuse ratings can be provided by Rehko on request.

We recommend that ALL AC power cables are sized for the full cabinet (300 kW) rating even if fewer than six UPS modules are installed initially, as this will allow the system to be expanded to include the full six modules at a later date without having to shut down the system for re-cabling.

### UPS cabinet cabling details for a single-feed input and common battery

UPS CABINET CONNECTIONS							
UPS Module Rating (kVA)		50	100	150	200	250	300
Cable A 1L1,1L2,1L3,1N, PE <sup>a</sup>	Input demand <sup>b</sup>	78A	157A	236A	314A	393A	471A
	Termination	5x M12					
	Tightening Torque	50-75 Nm					
Fuse A Agl/CB	3x <sup>b</sup>	80A	160A	250A	315A	400A	500A
Cable C <sup>c</sup> B+, B-, PE <sup>a</sup>	Nominal discharge current	90-110A	175-220A	260-330A	350-440A	435-550A	525-660A
	Termination	4x M10					
	Tightening Torque	35 Nm					
Fuse C <sup>d</sup> Agl/CB	2x	125A	250A	400A	500A	630A	700A
Cable D 3L1,3L2,3L3,3N,PE <sup>a</sup>	Rated output <sup>e</sup>	72A	144A	216A	288A	360A	433A
	Termination	5x M12					
	Tightening Torque	50-75 Nm					
Fuse D Agl/CB	3x	80A	160A	250A	315A	400A	500A

a. Protective Earth (PE) cable must be sized in accordance with local and national regulations

b. Rating shown for nominal 400V operation and batteries charging. See specification for 380/415V current ratings.

c. Bespoke to site, depending on the DC installation (supplied by Rehiko).

d. Bespoke to site, depending on the DC installation (supplied by Rehiko).

e. Rating shown for nominal 400V operation at full load @ 1.0PF. See specification for 380/415V current ratings.

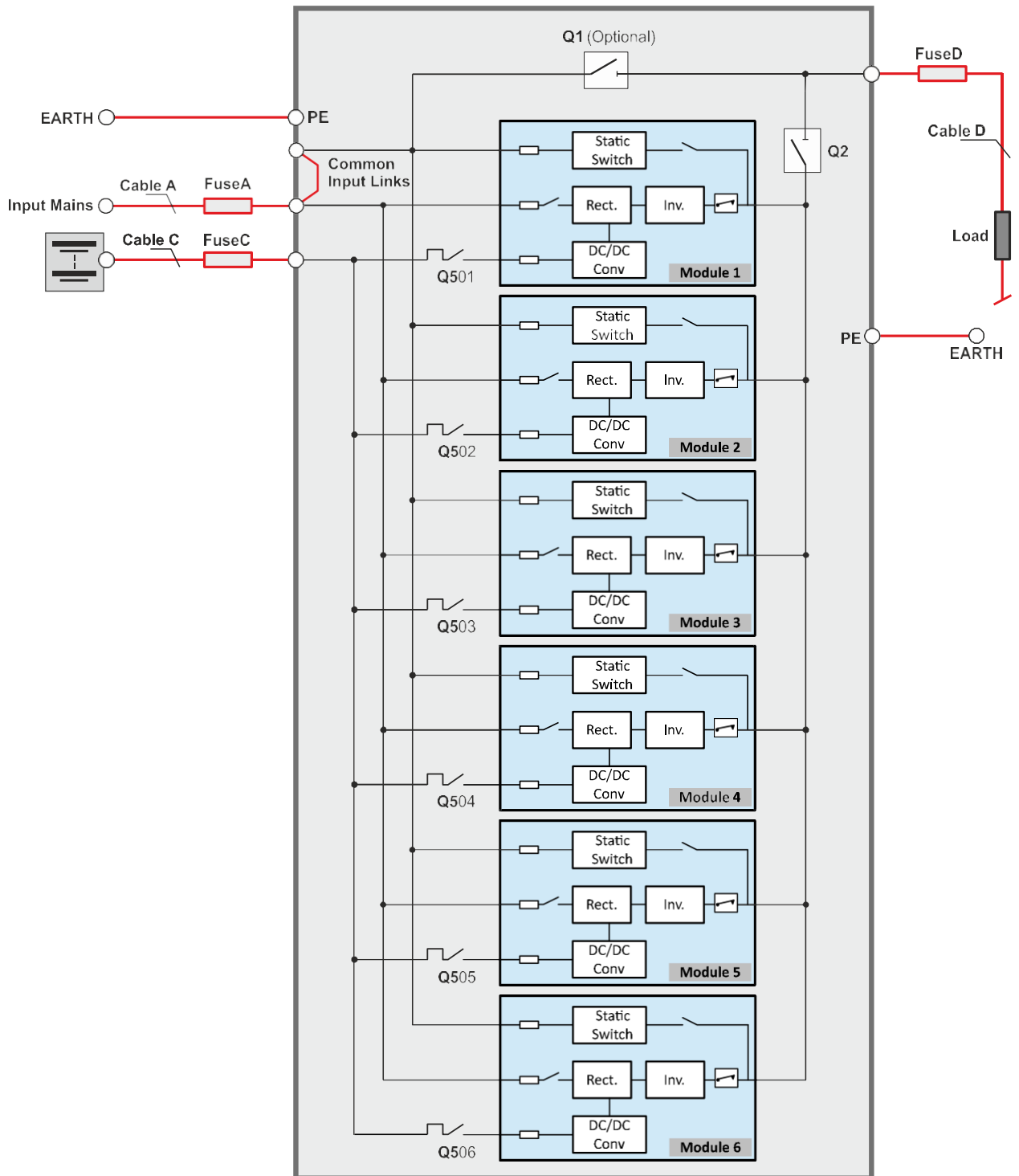

Figure 11 UPS cabinet cabling details for a single feed input and common battery

### UPS cabinet cabling details for a single-feed input and separate batteries

UPS CABINET CONNECTIONS								
UPS Module Rating (kVA)			50	100	150	200	250	300
Cable A	1L1,1L2,1L3,1N, PE <sup>a</sup>	Input demand <sup>b</sup>	78A	157A	236A	314A	393A	471A
		Termination	5x M12					
		Tightening Torque	50-75 Nm					
Fuse A	Agl/CB	3x <sup>b</sup>	80A	160A	250A	315A	400A	500A
Cable D	3L1,3L2,3L3,3N,PE <sup>a</sup>	Rated output <sup>c</sup>	72A	144A	216A	288A	360A	433A
		Termination	5x M12					
		Tightening Torque	50-75 Nm					
Fuse D	Agl/CB	3x	80A	160A	250A	315A	400A	500A
Cable E <sup>d</sup>	Q501-Q506, PE <sup>a</sup>	Nominal discharge current	90-110A for each UPS module					
		Termination	Circuit breaker screwed connections					
Fuse E <sup>e</sup>	Agl/CB	2x	(Nominal 125A for each UPS module -- see footnote)					

a. Protective Earth (PE) cable must be sized in accordance with local and national regulations

b. Rating shown for nominal 400V operation and batteries charging. See specification for 380/415V current ratings.

c. Rating shown for nominal 400V operation at full load @ 1.0PF. See specification for 380/415V current ratings.

d. Bespoke to site, depending on the DC installation (supplied by Rehiko).

e. Bespoke to site, depending on the DC installation (supplied by Rehiko).

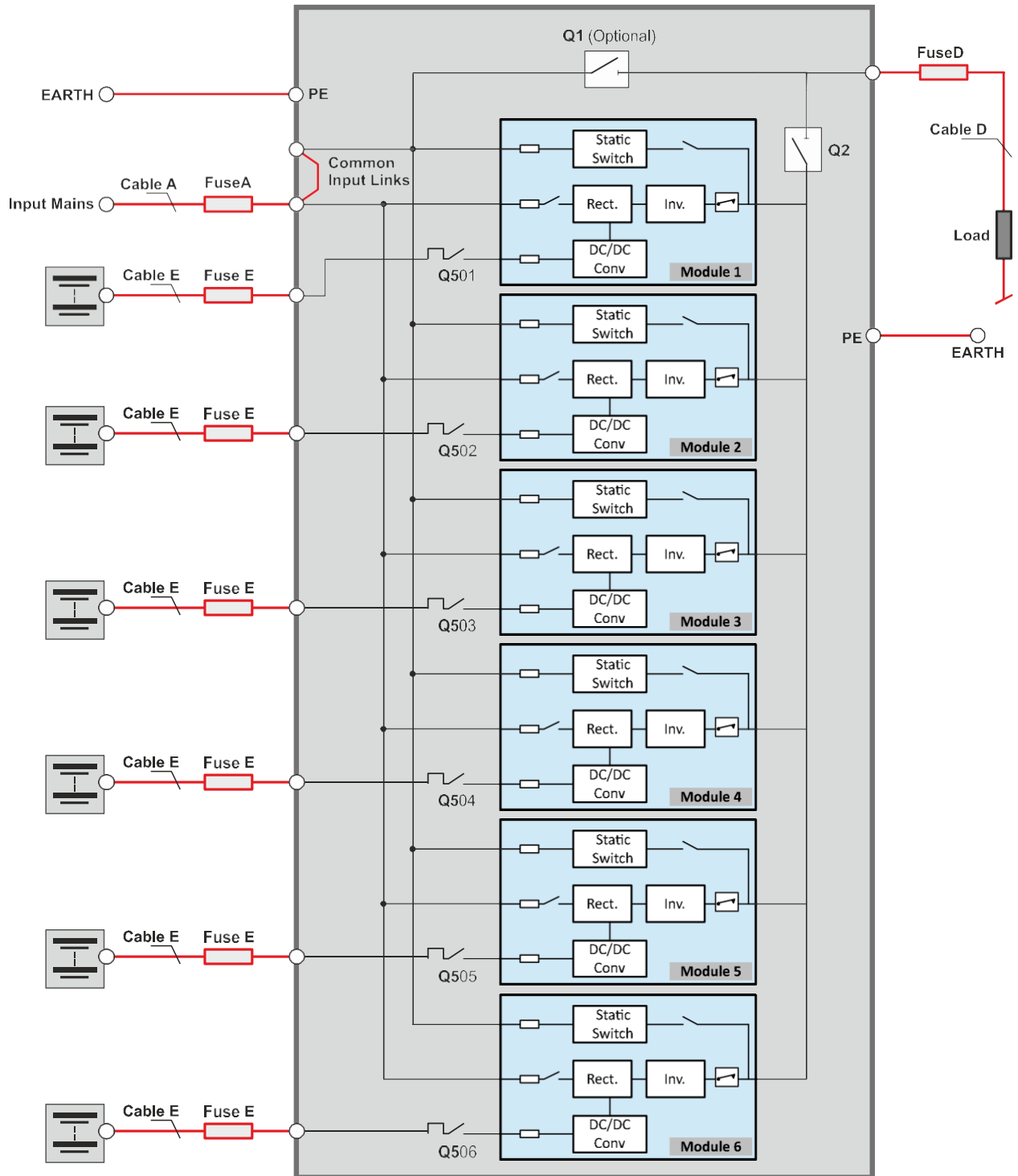

Figure 12 UPS cabinet cabling details for a single feed input and separate batteries

## UPS cabinet cabling details for a dual-feed input and common battery

UPS CABINET CONNECTIONS								
UPS Module Rating (kVA)			50	100	150	200	250	300
Cable A	1L1,1L2,1L3,1N, PE <sup>a</sup>	Input demand <sup>b</sup>	78A	157A	236A	314A	393A	471A
		Termination	5x M12					
		Tightening Torque	50-75 Nm					
Fuse A	Agl/CB	3x <sup>b</sup>	80A	160A	250A	315A	400A	500A
		Bypass demand <sup>c</sup>	72A	144A	216A	288A	360A	433A
		Termination	5x M12					
		Tightening Torque	50-75 Nm					
Fuse B	Agl/CB	3x	80A	160A	250A	315A	400A	500A
Cable C <sup>d</sup>	B+, B-, PE <sup>a</sup>	Nominal discharge current	90-110A	175-220A	260-330A	350-440A	435-550A	525-660A
		Termination	4x M10					
		Tightening Torque	35 Nm					
Fuse C <sup>e</sup>	Agl/CB	2x	125A	250A	400A	500A	630A	700A
Cable D	3L1,3L2,3L3,3N,PE <sup>a</sup>	Rated output <sup>f</sup>	72A	144A	216A	288A	360A	433A
		Termination	5x M12					
		Tightening Torque	50-75 Nm					
Fuse D	Agl/CB	3x	80A	160A	250A	315A	400A	500A

a. Protective Earth (PE) cable must be sized in accordance with local and national regulations

b. Rating shown for nominal 400V operation and batteries charging. See specification for 380/415V current ratings.

c. Rating shown for nominal 400V operation at full load @ 1.0PF. See specification for 380/415V current ratings.

d. Bespoke to site, depending on the DC installation (supplied by Rehlko).

e. Bespoke to site, depending on the DC installation (supplied by Rehlko).

f. Rating shown for nominal 400V operation at full load @ 1.0PF. See specification for 380/415V current ratings.

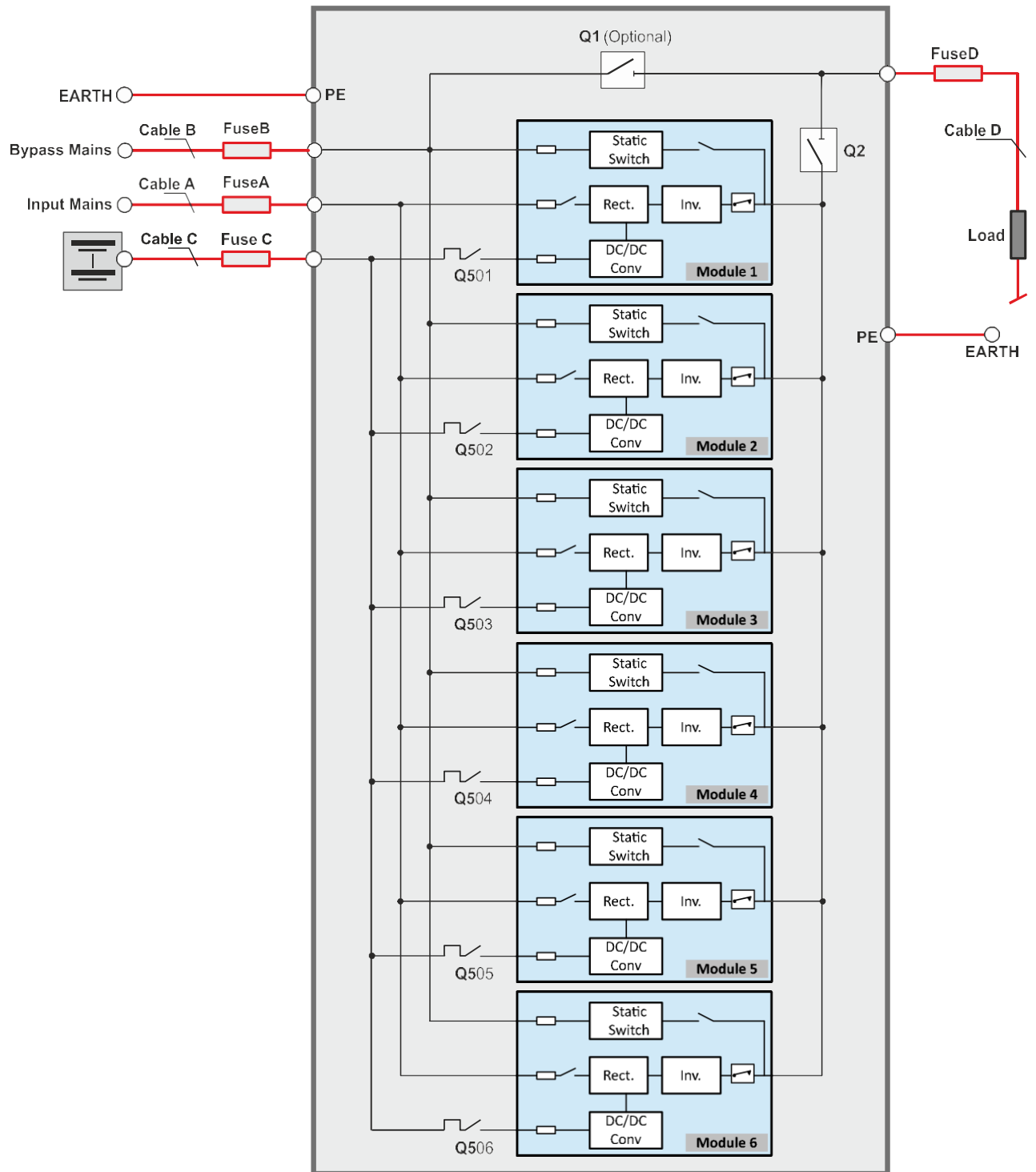

Figure 13 UPS cabinet cabling details for a dual-feed input and common battery

### UPS cabinet cabling details for a dual-feed input and separate batteries

UPS CABINET CONNECTIONS								
UPS Module Rating (kVA)			50	100	150	200	250	300
Cable A	1L1,1L2,1L3,1N, PE <sup>a</sup>	Input demand <sup>b</sup>	78A	157A	236A	314A	393A	471A
		Termination	5x M12					
		Tightening Torque	50-75 Nm					
Fuse A	Agl/CB	3x <sup>b</sup>	80A	160A	250A	315A	400A	500A
Cable B	1L1,1L2,1L3,1N, PE <sup>a</sup>	Bypass demand <sup>c</sup>	72A	144A	216A	288A	360A	433A
		Termination	5x M12					
		Tightening Torque	50-75 Nm					
Fuse B	Agl/CB	3x	180A	160A	250A	315A	400A	500A
Cable D3	L1,3L2,3L3,3N,PE <sup>a</sup>	Rated output <sup>d</sup>	72A	144A	216A	288A	360A	433A
		Termination	5x M12					
		Tightening Torque	50-75 Nm					
Fuse D	Agl/CB	3x	80A	160A	250A	315A	400A	500A
Cable E <sup>e</sup>	Q501-Q506, PE <sup>a</sup>	Nominal discharge current	90-110A for each UPS module					
		Termination	Circuit breaker screwed connections					
Fuse E <sup>f</sup>	Agl/CB	2x	(Nominal 125A for each UPS module -- see footnote)					

a. Protective Earth (PE) cable must be sized in accordance with local and national regulations

b. Rating shown for nominal 400V operation and batteries charging. See specification for 380/415V current ratings.

c. Rating shown for nominal 400V operation at full load @ 1.0PF. See specification for 380/415V current ratings.

d. Rating shown for nominal 400V operation at full load @ 1.0PF. See specification for 380/415V current ratings.

e. Bespoke to site, depending on the DC installation (supplied by Rehiko).

f. Bespoke to site, depending on the DC installation (supplied by Rehiko).

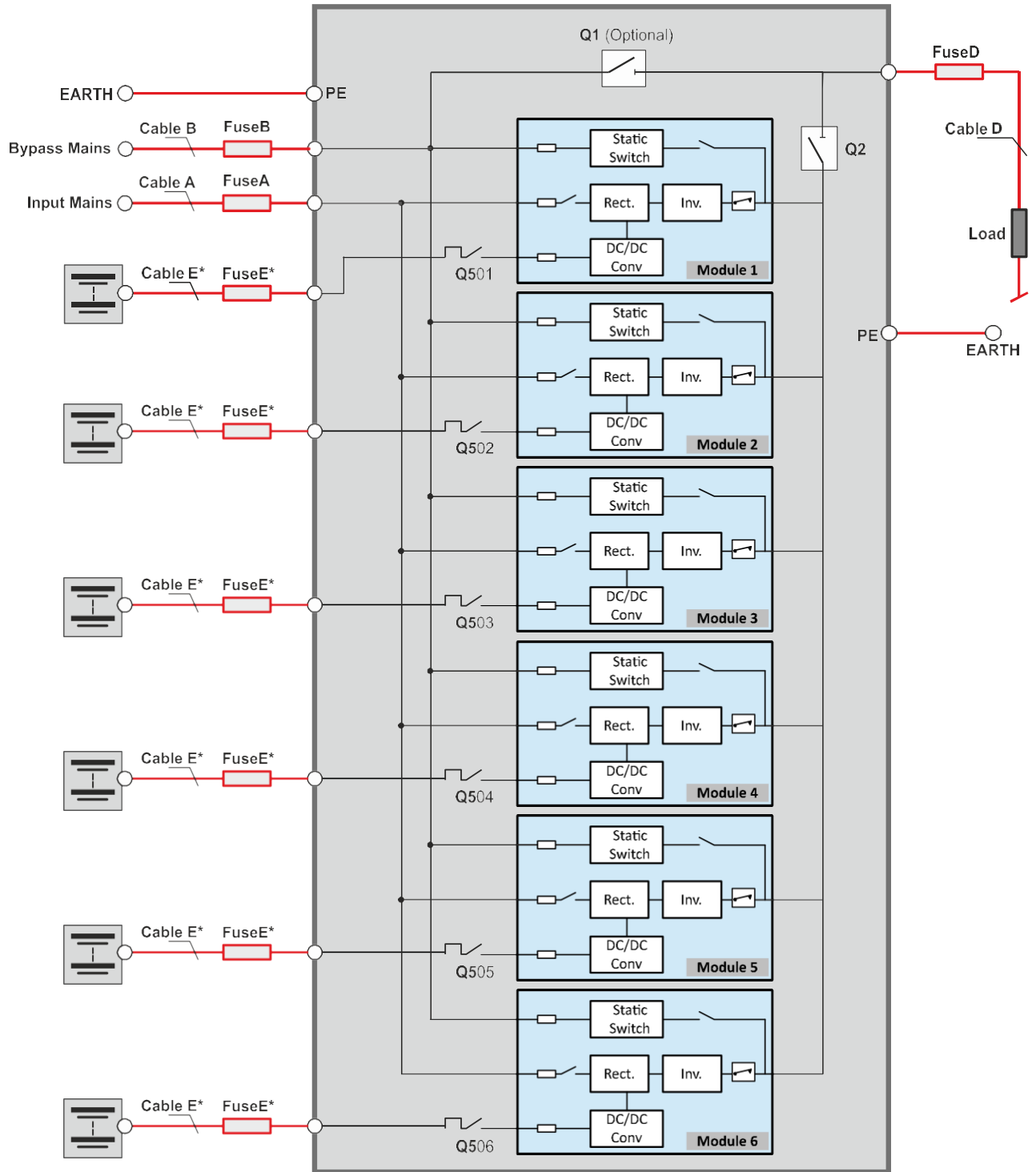

Figure 14 UPS cabinet cabling details for a dual-feed input and separate batteries